

Technical light solutions

Technische Lichtlösungen
Solutions d'éclairage techniques



EDITORIAL

Dear business partners and loyal EGLO friends,

with pleasure, we present our current range of technical lighting solutions. This range stands for high functionality, versatile application possibilities, and modern lighting solutions. From LED panels and recessed spotlights to flexible track systems and the new GLOW concept with light tubes that create an atmospheric and architecturally inspired lighting effect in living spaces, the range offers a wide variety of options for individual lighting design.

Geschätzte Geschäftspartner*innen, treue EGLO Freund*innen,

mit Freude präsentieren wir unser aktuelles Sortiment technischer Lichtlösungen. Dieses Sortiment steht für hohe Funktionalität, vielseitige Einsatzmöglichkeiten sowie moderne Beleuchtungslösungen. Von LED-Paneelen und Einbauspots über flexible Schienensysteme bis hin zum neuen Konzept GLOW mit Lichtschläuchen, die in Wohnräumen eine atmosphärische und architektonisch inspirierte Lichtwirkung schaffen, bietet das Sortiment vielfältige Möglichkeiten für eine individuelle Lichtgestaltung.

Chers partenaires commerciaux, fidèles amis d'EGLO,

c'est avec plaisir que nous vous présentons notre gamme actuelle de solutions d'éclairage technique. Cette gamme se distingue par sa grande fonctionnalité, ses nombreuses possibilités d'utilisation ainsi que par ses solutions d'éclairage modernes. Des panneaux LED et spots encastrés aux systèmes sur rail flexibles, jusqu'au nouveau concept GLOW avec ses tubes lumineux qui créent dans les espaces de vie un effet lumineux à la fois chaleureux et inspiré par l'architecture, la gamme offre de nombreuses possibilités pour une conception d'éclairage personnalisée.

CONTENT

Inhalt / Contenu



1



2

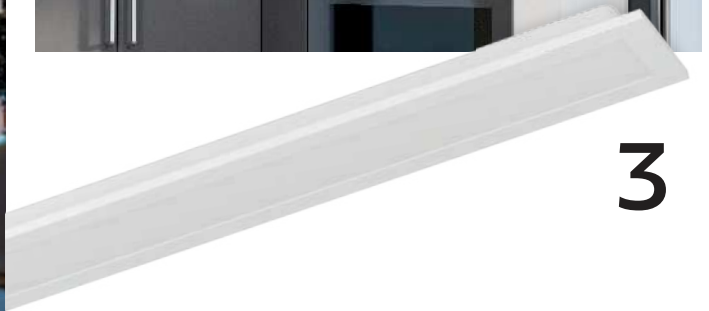

3

1 EGLO CONNECT.Z

EGLO CONNECT.Z
EGLO CONNECT.Z

14

2 TRACK SYSTEM

SCHIENENSYSTEM
SYSTÈMES DE RAIL

- EASY TRACK
- TRACK PLUS

62

3 LED PANEL LUMINAIRES

LED PANEELLEUCHTEN
LUMINAIRES PANNEAUX LED
- WITH FRAME

90

4 RECESSED DOWNLIGHTS

EINBAULEUCHTEN
DOWNLIGHTS ENCASTRÉS

- HIGH & LOW VOLTAGE
- BASIC
- COMFORT
- PREMIUM
- WITH SOCKET

116



4



5



6

**5 SURFACE
DOWNLIGHTS**

AUFBAULEUCHTEN
LUMINAIRES DE SURFACE

178

**7 INDEX &
LEGEND**

INDEX & ERKLÄRUNG
INDEX & LÉGENDE

206

6 GLOW

GLOW
GLOW

200

PROTECTION CLASS OVERVIEW
 SCHUTZKLASSENÜBERSICHT
 APERÇU DES CLASSES DE PROTECTION



IP20



IP44



IP65

IP20

IP20 luminaires are sufficient for living areas and kitchens. For degrees higher than IP20, the degree of protection is specified in the information box of the luminaires.

Für den Wohnbereich und in der Küche sind IP20-Leuchten ausreichend. Bei höheren Graden als IP20 wird der Schutzgrad im Infokasten der Leuchten angegeben.

Pour l'habitat et la cuisine, les luminaires IP20 sont suffisants. Pour les degrés supérieurs à IP20, le degré de protection est indiqué dans la boîte d'information des luminaires.

IP44

Luminaires in the area of up to 60 cm around the bath or shower and up to a height of 2.25 m must be protected against splashing water.

Leuchten im Bereich von bis zu 60 cm um die Badewanne oder Dusche und bis zu einer Höhe von 2,25 m müssen gegen Spritzwasser geschützt sein.

Les luminaires situés jusqu'à 60 cm autour de la baignoire ou de la douche et jusqu'à une hauteur de 2,25 m doivent être protégés contre les projections d'eau.

IP65

Up to a height of 2.25 m around the shower head and bath or shower tray, luminaires must be protected against water jets and may only be operated with safety extra-low voltage up to AC 25 volts or DC 60 volts.

Bis zu einer Höhe von 2,25 m rund um die Duschbrause sowie Bade- oder Duschwanne müssen Leuchten strahlwassergeschützt sein und dürfen ausschließlich mit Schutzkleinspannung bis 25 Volt oder 60 Volt betrieben werden.

Jusqu'à une hauteur de 2,25 m autour de la douchette ainsi que du bain ou du bac à douche, les luminaires doivent être protégés contre les jets d'eau et ne peuvent être alimentés qu'avec une basse tension de protection jusqu'à 25 volts ou 60 volts.



Look for this button!
 Suchen Sie nach diesem Button!
 Cherchez ce bouton!

SOLIDS / FESTSTOFFE / SOLIDES

0	Non protected. Nicht geschützt. Non protégé.
1	Protected against a solid object greater than 50 mm, such as a hand. Geschützt gegen feste Gegenstände, die größer als 50 mm sind, wie z. B. eine Hand. Protégé contre un objet solide de plus de 50 mm, comme une main.
2	Protected against a solid object greater than 12 mm, such as a finger. Geschützt gegen feste Gegenstände, die größer als 12 mm sind, wie z. B. einen Finger. Protégé contre un objet solide de plus de 12 mm, tel qu'un doigt.
3	Protected against a solid object greater than 2,5 mm, such as a screw driver. Geschützt gegen feste Gegenstände, die größer als 2,5 mm sind, z. B. einen Schraubendreher. Protégé contre un objet solide supérieur à 2,5 mm, tel qu'un tournevis.
4	Protected against a solid object greater than 1 mm, such as a screw or wire. Geschützt gegen feste Gegenstände, die größer als 1 mm sind, wie z. B. Schrauben oder Drähte. Protégé contre un objet solide de plus de 1 mm, tel qu'une vis ou un fil.
5	Dust protected. Prevents ingress of dust sufficient to cause harm. Staubgeschützt. Verhindert das Eindringen von Staub, der ausreicht, um Schäden zu verursachen. Protégé contre la poussière. Empêche la pénétration de poussière suffisamment pour causer des dommages.
6	Dust tight. No ingress of dust. Staubdicht. Kein Eindringen von Staub. Étanche à la poussière. Pas de pénétration de poussière.

WATER / WASSER / L'EAU

0	Non protected. Nicht geschützt. Non protégé.
1	Protected against vertical dripping water. Limited liquid entry. Geschützt gegen senkrecht tropfendes Wasser. Eingeschränkter Flüssigkeitseintrag. Protégé contre les gouttes d'eau verticales. Entrée de liquide limitée.
2	Protected against vertical dripping water below 15°. Limited liquid ingress. Geschützt gegen senkrecht tropfendes Wasser unter 15°. Eingeschränkter Flüssigkeitseintrag. Protégé contre les gouttes d'eau verticales à moins de 15°. Entrée de liquide limitée.
3	Protected against water spray at an angle of up to 60°. Limited liquid ingress. Geschützt gegen Sprühwasser in einem Winkel bis 60°. Eingeschränkter Flüssigkeitseintrag. Protégé contre les projections d'eau à un angle allant jusqu'à 60°. Entrée de liquide limitée.
4	Protected against splashing water from any direction. Limited liquid ingress. Geschützt gegen Spritzwasser aus beliebiger Richtung. Eingeschränkter Flüssigkeitseintrag. Protégé contre les projections d'eau de n'importe quelle direction. Entrée de liquide limitée.
5	Protected against jets of water from all directions. Limited liquid entry. Geschützt gegen Strahlwasser aus allen Richtungen. Eingeschränkter Flüssigkeitseintrag. Protégé contre les jets d'eau de toutes directions. Entrée de liquide limitée.
6	Protected against powerful jets of water from all directions. Limited liquid entry. Geschützt gegen starke Wasserstrahlen aus allen Richtungen. Eingeschränkter Flüssigkeitseintrag. Protégé contre les jets d'eau puissants de toutes les directions. Entrée de liquide limitée.
7	Protected against the effects of water immersion between 15 cm and 1 m. Geschützt gegen die Auswirkungen von Wassereintauchen zwischen 15 cm und 1 m. Protégé contre les effets d'une immersion dans l'eau entre 15 cm et 1 m.
8	Protected against the effects of water immersion under pressure beyond 1 m. Geschützt gegen die Auswirkungen des Eintauchens in Wasser unter Druck über 1 m. Protégé contre les effets de l'immersion dans l'eau sous pression au-delà de 1 m.

IP44

For more detailed information see DIN EN 60598.
Für genauere Informationen siehe DIN EN 60598.
Pour des informations plus détaillées, voir DIN EN 60598.

REMOTE +

REMOTE +
REMOTE+

Our new 2.4 GHz REMOTE+ makes it easier than ever to control your luminaires. With its user-friendly design and simple control, you can easily adjust your luminaires to create the perfect ambiance for any occasion:

- Stepless Dimming
- Quick Pairing
- Timer Function
- Stepless Tunable White
- Memory Effect
- Control up to 10 REMOTE+ luminaires

Unsere neue 2,4-GHz REMOTE+ macht die Steuerung Ihrer Leuchten so einfach wie nie zuvor. Mit ihrem benutzerfreundlichen Design und der einfachen Steuerung können Sie Ihre Leuchten ganz einfach einstellen, um das perfekte Ambiente für jede Gelegenheit zu schaffen:

- Stufenloses Dimmen
- Schnelle Kopplung
- Timer-Funktion
- Stufenlos einstellbares Weiß
- Memory-Effekt
- Steuerung von bis zu 10 REMOTE+ Leuchten

Notre nouvelle REMOTE+ 2,4 GHz facilite plus que jamais le contrôle de vos lumières. Grâce à sa conception conviviale et à sa commande simple, vous pouvez facilement régler votre luminaires pour créer l'ambiance parfaite en toute occasion:

- Gradation progressive
- appairage rapide
- Fonction de minuterie
- Blanc réglable en continu
- Effet de mémoire
- Contrôle jusqu'à 10 luminaires REMOTE+



Look for this button!
Suchen Sie nach diesem Button!
Cherchez ce bouton!

1. LED
2. ON / OFF – Press and hold 3 seconds for pairing
3. Selection of group
4. Brightness adjustments
5. White presets
6. White adjustments
7. RGB presets
8. Timer – Press within 3 seconds:
 - Once for a 15-minute timer,
 - Twice for a 30-minute timer,
 - Three times for a 45-minute timer.
 The light will turn off automatically afterward.
9. Special effects
10. Favourites – One press to apply, press and hold 3 seconds to store

1. LED
2. EIN / AUS – Halten Sie es zum Koppeln 3 Sekunden lang gedrückt
3. Auswahl der Gruppe
4. Helligkeitseinstellungen
5. Weißvoreinstellungen
6. Weiß-Einstellungen
7. RGB-Voreinstellungen
8. Timer – Drücken Sie innerhalb von 3 Sekunden:
 - 1-mal für einen 15-Minuten-Timer,
 - 2-mal für einen 30-Minuten-Timer,
 - 3-mal für einen 45-Minuten-Timer.
 Das Licht schaltet sich danach automatisch aus.
9. Spezialeffekte
10. Favoriten – Drücken Sie 1-mal zum Anwenden, drücken Sie 3 Sekunden lang zum Speichern

1. LED
2. ALLUMEZ / ÉTEINDRA – Appuyez et maintenez 3 secondes pour l'appairage
3. Sélection du groupe
4. Réglages de luminosité
5. Réglages du blanc
6. Paramètres du blanc
7. Préréglages RVB
8. Minuteur – Appuyez dans un délai de 3 secondes :
 - 1 fois pour un minuteur de 15 minutes,
 - 2 fois pour un minuteur de 30 minutes,
 - 3 fois pour un minuteur de 45 minutes.
 La lumière s'éteindra automatiquement ensuite.
9. Effets spéciaux
10. Favoris – Appuyez une fois pour appliquer, appuyez et maintenez 3 secondes pour sauvegarder

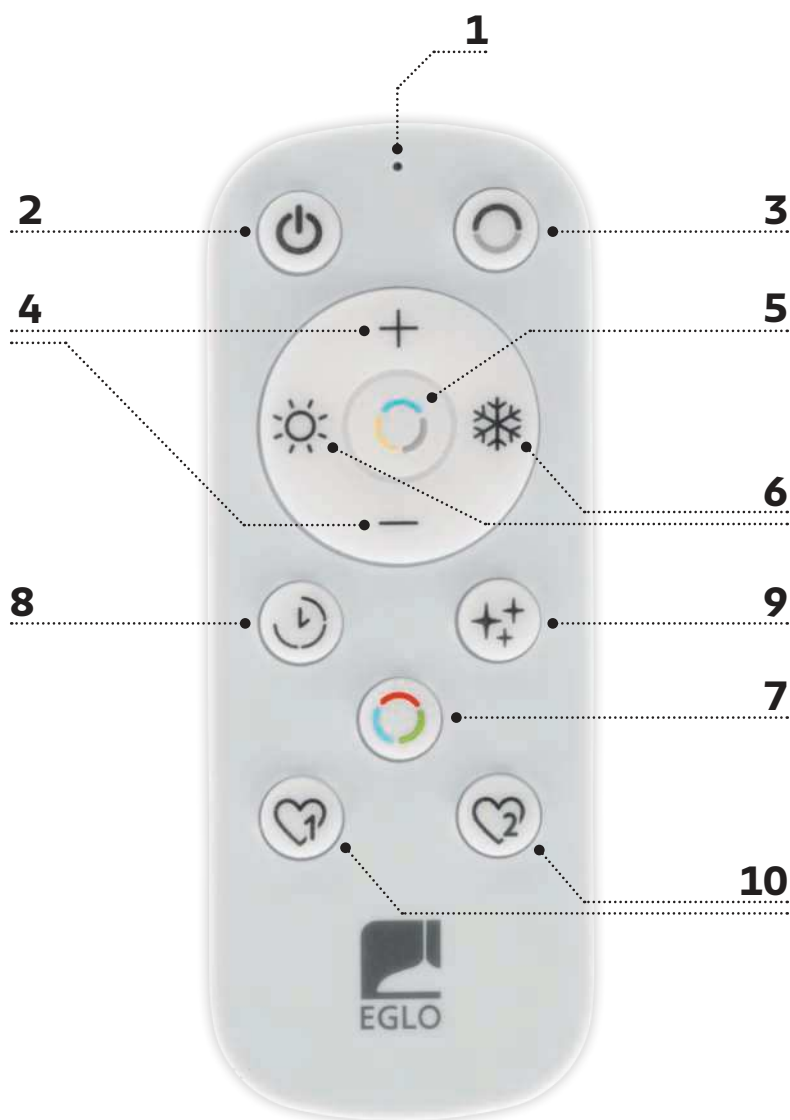

EGLO PUCK
EGLO PUCK
EGLO PUCK

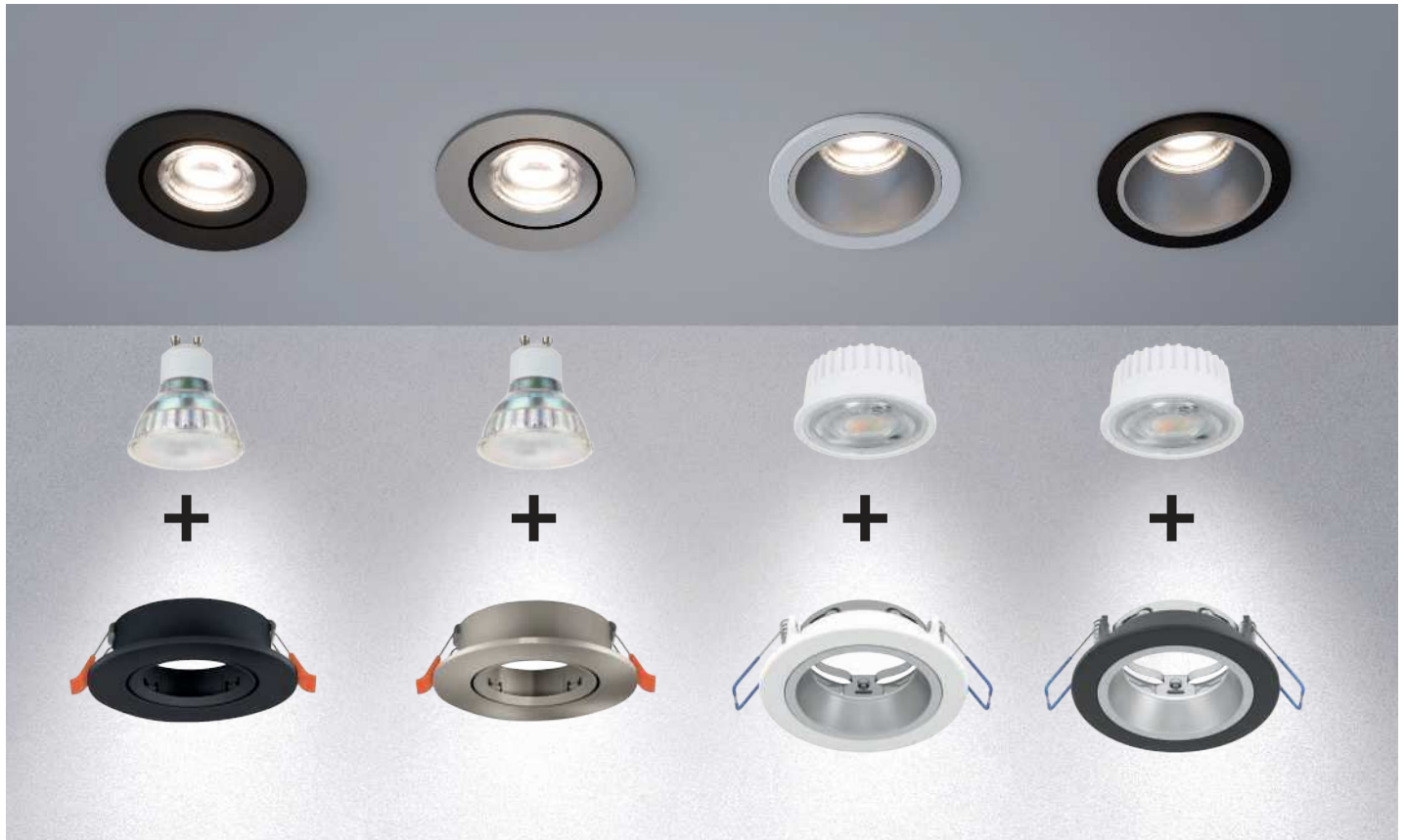

PUCK VS GU10

The EGLO PUCK has the same dimensions as a GU10 light source and fits effortlessly into standard recessed downlights. This makes it easy to modernise existing luminaires and create stylish accents. While conventional GU10 downlights require an installation depth of at least 85 mm, the EGLO PUCK requires only 30 mm - the ideal solution for shallow cavities and simple modernisation of existing luminaires.

Der EGLO PUCK hat die gleichen Maße wie ein GU10-Leuchtmittel und passt mühelos in Standard-Einbaustrahler. So lassen sich bestehende Leuchten einfach modernisieren und stilvolle Akzente setzen. Während herkömmliche GU10-Spots eine Einbautiefe von mindestens 85 mm benötigen, kommt der EGLO PUCK mit nur 30 mm aus – die ideale Lösung für flache Hohlräume und eine einfache Modernisierung bestehender Leuchten.

EGLO PUCK a les mêmes dimensions qu'une ampoule GU10 et s'adapte sans effort aux spots encastrés standard. Il est donc facile de moderniser les luminaires existants et d'ajouter des touches de style. Alors que les spots GU10 traditionnels nécessitent une profondeur d'encastrement d'au moins 85 mm, le PUCK d'EGLO se contente de seulement 30 mm - la solution idéale pour les espaces creux peu profonds et pour moderniser facilement les luminaires existants.

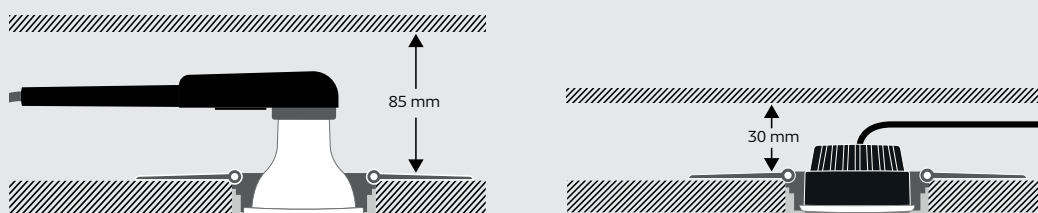



902333

Designed for bathroom zone 1 – driver separate from the circuit board.

Geeignet für Badezimmer Zone 1 – Treiber getrennt von der Platine.

Conçu pour la zone 1 de la salle de bains – pilote séparé du circuit imprimé.



902335 902334



902338



902336

EGLO PUCK ADVANTAGES

- Sustainability: Only the LED module needs to be replaced, not the entire spotlight - this reduces waste.
- Cost savings: Less expensive, as only individual modules need to be purchased instead of complete spots.
- Future-proof: Possibility to upgrade to newer, more efficient LED technologies.
- Easy maintenance: Defective modules can be replaced quickly and easily.
- Flexibility: Function or light intensity can be adapted to changing requirements by replacing the module.
- Thanks to the included connection box, you can chain our pucks endlessly.

- Nachhaltigkeit: Nur das LED-Modul muss ersetzt werden, nicht der gesamte Spot – das reduziert Abfall.
- Kostenersparnis: Günstiger, da nur einzelne Module statt komplette Spots gekauft werden müssen.
- Zukunftssicherheit: Möglichkeit, auf neuere, effizientere LED-Technologien aufzurüsten.
- Einfache Wartung: Defekte Module lassen sich schnell und unkompliziert austauschen.
- Flexibel: Funktion oder Lichtstärke können durch Austausch des Moduls an veränderte Anforderungen angepasst werden.
- Durch die enthaltene Anschlussbox, können Sie unsere Pucks endlos verketteten.

- Durabilité : Seul le module LED doit être remplacé, et non l'ensemble du projecteur, ce qui réduit les déchets.
- Réduction des coûts : Moins cher, car il suffit d'acheter des modules individuels au lieu de spots complets.
- Résolument tourné vers l'avenir : Possibilité de passer à des technologies LED plus récentes et plus efficaces.
- Facilité de maintenance : Les modules défectueux peuvent être remplacés rapidement et facilement.
- Flexibilité : Le remplacement du module permet d'adapter la fonction ou l'intensité lumineuse à l'évolution des besoins.
- Grâce à la boîte de connexion incluse, vous pouvez enchaîner nos palets sans fin.

The technical data and article details can be found on [pages 122-123](#).
Die technischen Daten und Artikeldetails finden Sie auf [Seite 122-123](#).
Vous trouverez les données techniques et les détails des articles aux [pages 122-123](#).

EGLO CONNECT.Z

EGLO CONNECT.Z

EGLO CONNECT.Z

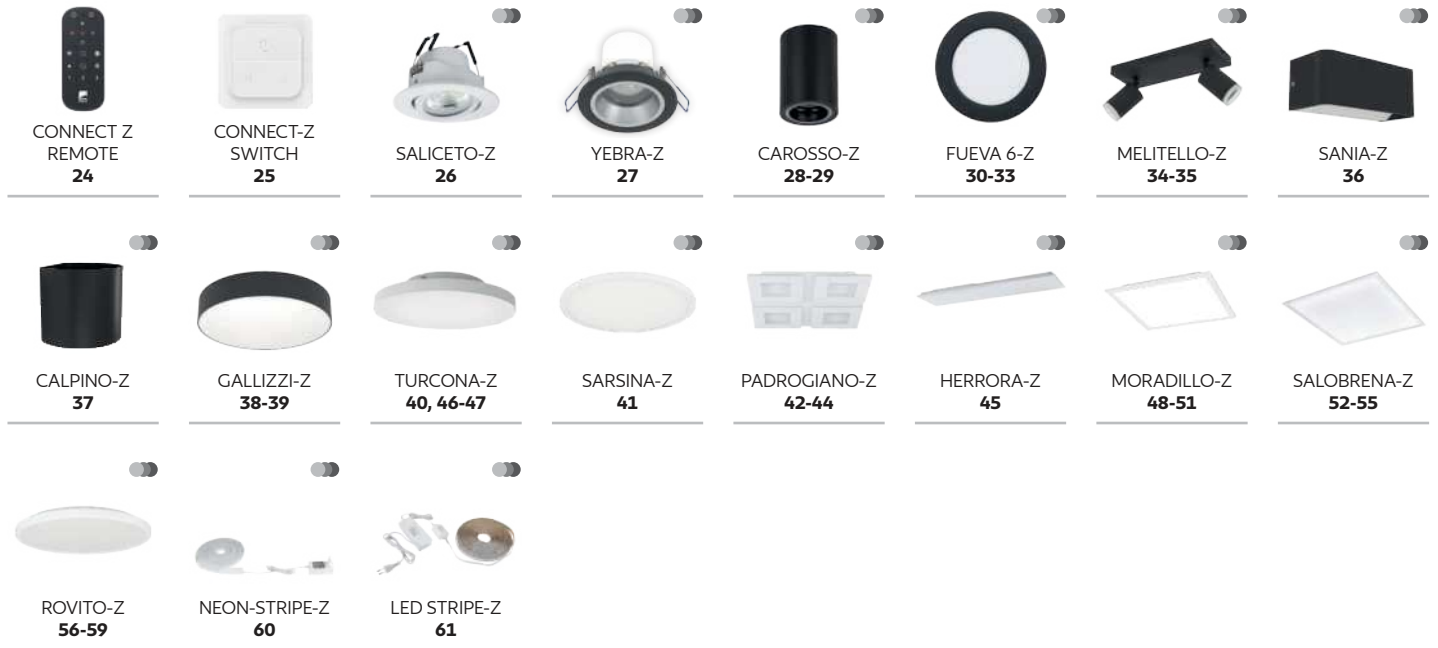

TRACK SYSTEM

SCHIENENSYSTEM

SYSTÈMES DE RAIL

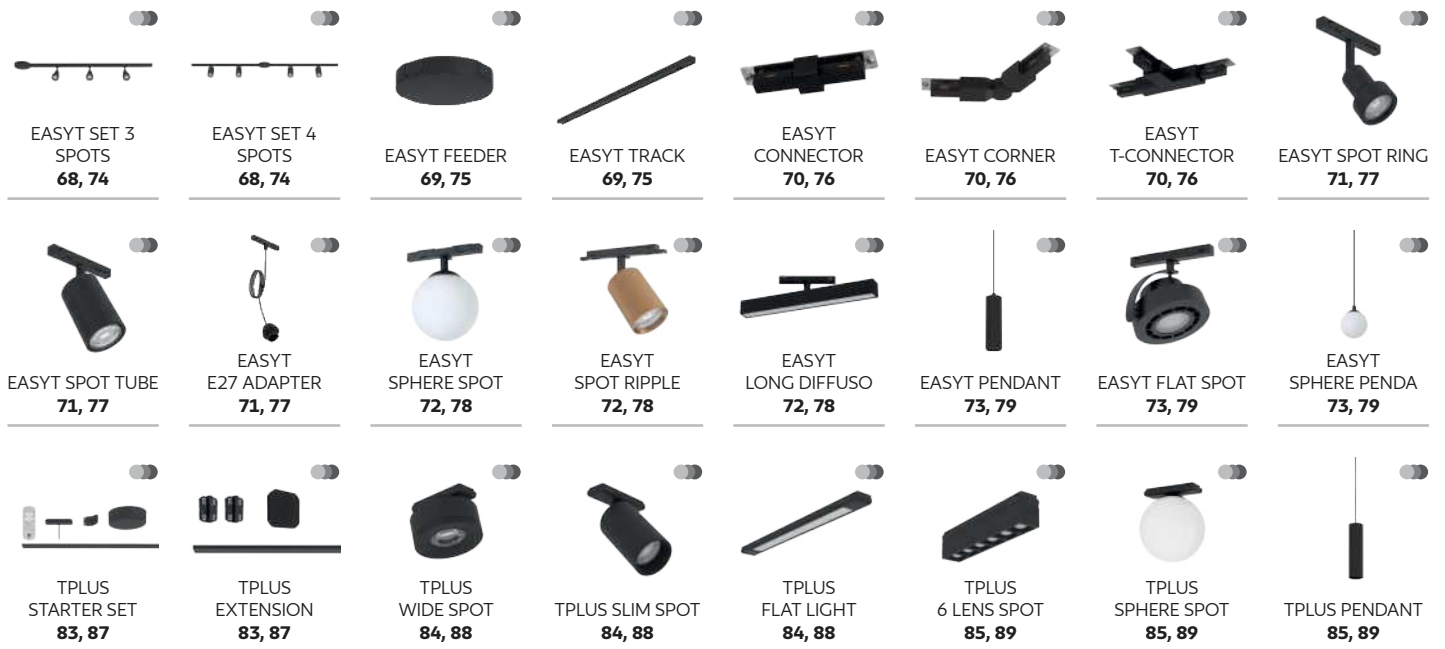

LED PANEL LUMINAIRES

LED PANEELLEUCHTEN
LUMINAIRES PANNEAUX LED



RECESSED DOWNLIGHTS

EINBAULEUCHTEN
DOWNLIGHTS ENCASTRÉS



This product is available in different colors and shapes. / Dieser Artikel ist in unterschiedlichen Farben und Formen verfügbar. / Cet article est disponible en différentes couleurs et formes.

SURFACE DOWNLIGHTS

AUFBAULEUCHTEN

LUMINAIRES DE SURFACE



FUEVA 6
184-191



FUEVA 5
192-193



FUEVA 1
194-195



CRESPILLO
196



KOB LED
197



POLASSO
198



BOHOYO
199

GLOW

GLOW

GLOW



GLOW WW
204



GLOW NW
204



GLOW RGBW
205



This product is available in different colors and shapes. / Dieser Artikel ist in unterschiedlichen Farben und Formen verfügbar. / Cet article est disponible en différentes couleurs et formes.



connect.z

DISCOVER THE SMART WORLD



LIGHT UP YOUR WORLD!

Bringen Sie Licht in Ihren Alltag!
Illuminez votre quotidien !

Choose the perfect mood for your home from thousands of colours.

Wählen Sie aus tausenden von Farben die perfekte Stimmung für Ihr Zuhause.

Choisissez parmi des milliers de couleurs l'ambiance parfaite pour votre maison.

✓ Tunable White



Individual light from
50,000 white tones.

Individuelles Licht aus
50.000 Weißtönen.

Luminaire individuel à
50 000 tons de blanc.

✓ Tunable White + RGB Colours



Diverse lighting selection
from 50,000 white tones
and 16 million colours.

Vielseitige Lichtauswahl
aus 50.000 Weißtönen
und 16 Millionen Farben.

Sélection étendue de
luminaires à 50 000 tons
de blanc et 16 millions de
couleurs.

START QUICKLY AND EASILY WITH A REMOTE CONTROL CONNECTION

Starten Sie schnell und einfach mit einer Fernbedienungsverbindung
Démarez rapidement et facilement avec votre télécommande

You want to start with a remote control?

No problem, of course all our smart lights can also be controlled without an app.

Sie wollen vorerst nur eine Fernbedienung verwenden?

Kein Problem, natürlich sind all unsere smarten Leuchten auch ohne App steuerbar.

Vous souhaitez utiliser uniquement la télécommande pour commencer ?

Pas de problème, tous nos luminaires intelligents peuvent bien sûr être contrôlés sans application.

✓ connect.z remote

With the connect.z remote, our smart lights can be connected directly without an app or hub. Create up to 3 groups with the group buttons and connect up to 50 luminaires with one remote control.

Mit der connect.z remote lassen sich unsere smarten Leuchten direkt und ohne App oder Hub verbinden. Erstellen Sie bis zu 3 Gruppen mit den Gruppentasten und verbinden Sie bis zu 50 Leuchten mit einer Fernbedienung.

La télécommande connect.z remote permet de connecter directement nos luminaires intelligents, sans application ni hub. Créez jusqu'à 3 groupes avec les boutons de groupe et connectez jusqu'à 50 luminaires avec une seule télécommande.



✓ connect.z switch

With its three buttons, it not only enables luminaires to be switched on and off, but also dimming and changing the light colour. A favourite setting can also be saved on the switch.

Mit seinen drei Tasten ermöglicht er nicht nur das Ein- und Ausschalten von Leuchten, sondern auch das Dimmen und Ändern der Lichtfarbe. Zusätzlich ist am Switch eine Favoriten-Einstellung speicherbar.

Avec ses trois touches, il permet non seulement d'allumer et d'éteindre les luminaires, mais aussi de faire varier l'intensité et la couleur de la lumière. De plus, il est possible de mémoriser un réglage favori sur le commutateur.

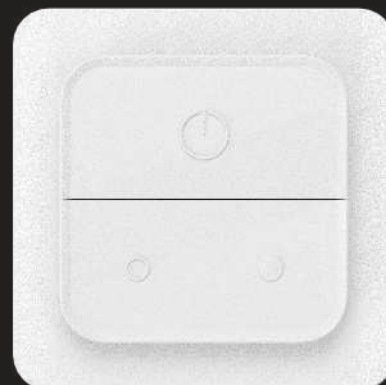



WORKS WITH BLUETOOTH APP CONNECTION

Funktioniert mit Bluetooth-App Verbindung

L'application fonctionne avec une connexion Bluetooth

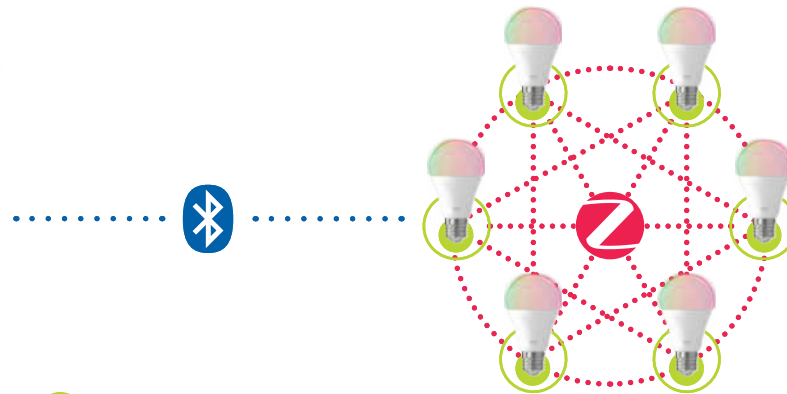

connect.z app

Connect our luminaires directly with Bluetooth and our app - no hub is required. The luminaires build a stable Zigbee network with each other, so up to 50 luminaires can be controlled using just a smartphone.

Verbinden Sie unsere Leuchten direkt mit Bluetooth und unserer App - es ist kein Hub notwendig. Die Leuchten bauen untereinander ein stabiles Zigbee Netzwerk auf, so können auch bis zu 50 Leuchten nur über das Smartphone gesteuert werden.

Connectez nos luminaires directement avec Bluetooth et notre application - aucun hub n'est nécessaire. Les luminaires établissent entre eux un réseau Zigbee stable, ce qui permet de contrôler jusqu'à 50 luminaires uniquement via le smartphone.

connect.z accessories

Also add our smart accessories (remote and switch) to the app for even more flexible control of your luminaires.

Fügen Sie auch unsere smarten Accessories (Remote und Switch) in der App hinzu, um eine noch flexiblere Steuerung Ihrer Leuchten zu ermöglichen.

Ajoute également nos accessoires intelligents (Remote et Switch) dans l'app pour un contrôle encore plus flexible de tes luminaires.



connect.z remote



connect.z switch

INFORMATION

You already own connect-c luminaires from the previous system? What now? No problem!

The previous connect-c products can be controlled together with the connect.z products via our app.

Sie besitzen bereits connect-c Leuchten des Vorgängersystems? Was nun? Kein Problem!

Die bisherigen connect-c Produkte können zusammen mit den connect.z Produkten über unsere App gesteuert werden.

Vous possédez déjà des luminaires connect-c de l'ancien système ? Et maintenant ? Pas de problème !

Les produits connect-c précédents peuvent être contrôlés avec les produits connect.z via notre application.



MAKE MORE OF YOUR LIGHT: DISCOVER OUR APP

Machen Sie mehr aus Ihrem Licht: Entdecken Sie unsere App

Tirez le meilleur parti de votre lumière : découvrez notre application



1

Timer and calendars

Make your daily life easier with timers and calendars. Develop your own lighting routines and make your life easier.

Timer und Kalender

Unterstützen Sie Ihren Alltag mit Timern und Kalendern. Entwickeln Sie eigene Lichtroutinen und machen Sie Ihr Leben leichter.

Minuterie et calendrier

Facilitez-vous la vie à l'aide de la fonction minuterie et calendrier. Développez vos propres routines d'éclairage et facilitez votre vie.

2

Light alarm clock

You'd rather not start your day in a bad mood? Wake up relaxed with the simulated sunrise.

Lichtwecker

Keine Lust mit schlechter Laune in den Tag zu starten? Entspannt aufwachen mit dem simulierten Sonnenaufgang.

Réveil lumineux

Pas envie de commencer la journée de mauvaise humeur? Réveillez-vous en douceur grâce au simulateur de lever de soleil.

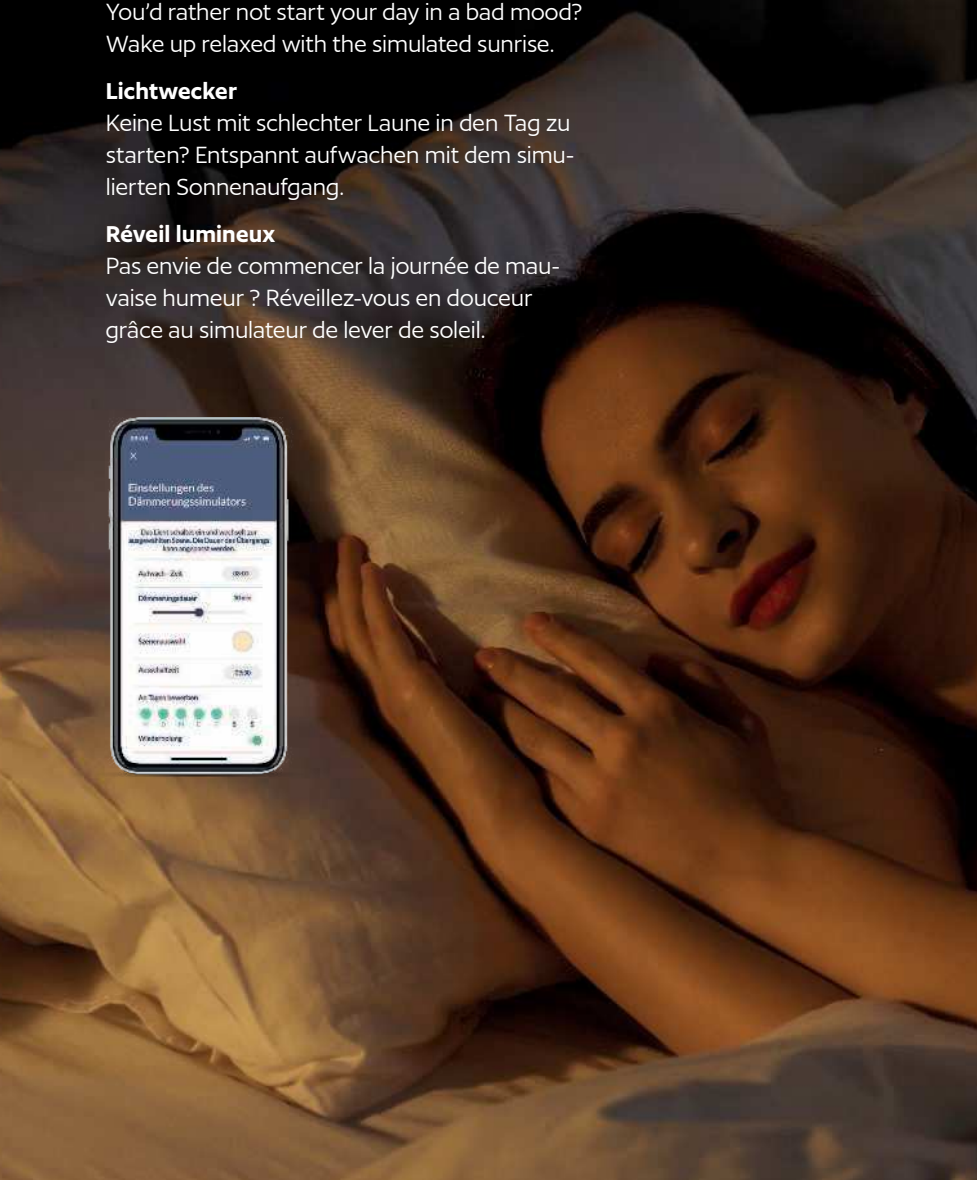

3

Disco function | mode

For the perfect party mood, the disco function synchronises the light to the beat of your favourite songs.

Discofunktion | modus

Für die perfekte Partystimmung schaltet die Discofunktion das Licht passend zum Beat Ihres Lieblingsongs.

Fonction | mode disco

Pour une ambiance festive parfaite, la fonction disco enclenche le luminaire au rythme de votre chanson préférée.

4

Presence simulator

Protect your home with the convenient presence simulator. Variable time intervals allow the system to turn the luminaires on and off to simulate your presence at home and deter unwanted guests.

Anwesenheitssimulation

Schützen Sie Ihr Zuhause mit der komfortablen Anwesenheitssimulation. Dank variabler Zeitintervalle simuliert das System durch Ein- und Ausschalten der Beleuchtung die Anwesenheit im Haus und schreckt so ungebetene Gäste ab.

Simulateur de présence

Protégez votre domicile à l'aide du très pratique simulateur de présence. Le système simule votre présence en allumant et en éteignant les lumières à intervalles variables et décourage ainsi les invités indésirables.

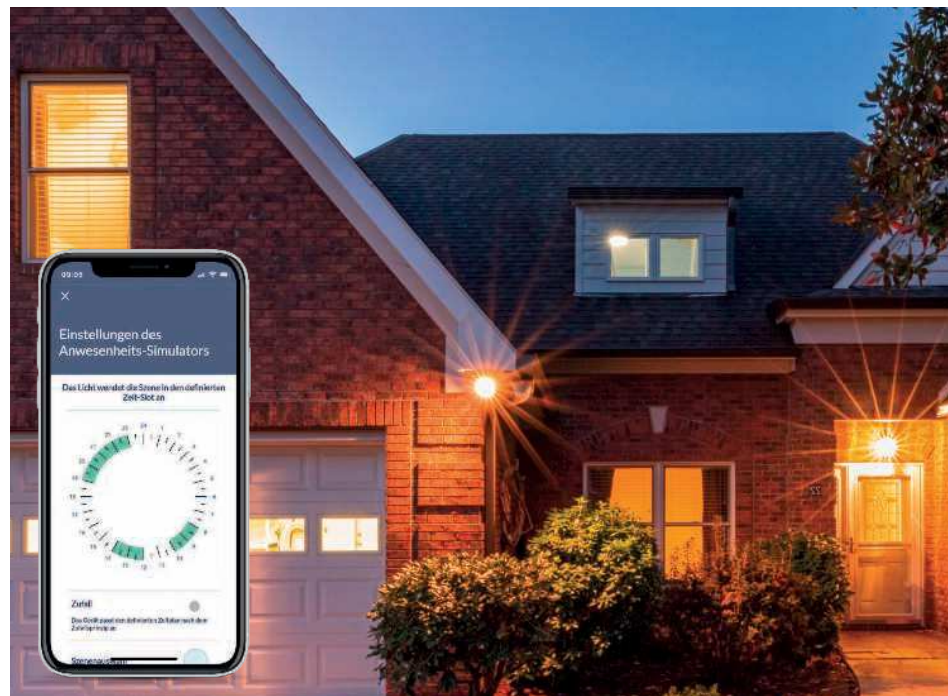

WORKS WITH GOOGLE HOME

Funktioniert mit Google Home
Funtionne avec Google Home



With Google Home, you can conveniently control our connect.z luminaires. Enjoy the benefits of smart lighting and effortlessly adjust the lighting mood, brightness, and colours to suit your individual needs – via voice command or app.

Mit Google Home haben Sie die Möglichkeit, unsere connect.z Leuchten komfortabel zu steuern. Nutzen Sie die Vorteile einer intelligenten Beleuchtung und passen Sie Lichtstimmung, Helligkeit und Farben mühelos an Ihre individuellen Bedürfnisse an – per Sprachbefehl oder über die App.

Avec Google Home, vous pouvez contrôler aisément nos luminaires connect.z. Profitez des avantages d'un éclairage intelligent et ajustez facilement l'ambiance lumineuse, la luminosité et les couleurs selon vos besoins – par commande vocale ou via l'application.

A hub may be required. | Ein Hub kann erforderlich sein. | Un hub peut être requis.

WORKS WITH ALEXA



Funktioniert mit Alexa
Fonctionne avec Alexa

Enjoy the comfort of creating your ideal living room lighting ambience with just one voice command.

Genießen Sie den Komfort, Ihr ideales Beleuchtungsambiente im Wohnzimmer mit nur einem Sprachbefehl zu gestalten.

Profitez du confort de créer votre ambiance d'éclairage idéale dans le salon avec une seule commande vocale.

With integrated Zigbee Hub

Mit integriertem Zigbee Hub

Avec Hub Zigbee intégré

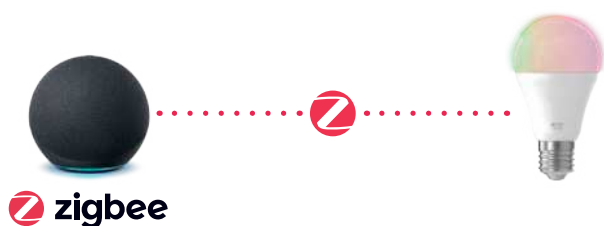

Your Alexa has an integrated Zigbee hub?

Perfect! You can connect our luminaires directly to Alexa.

Ihre Alexa hat einen integrierten Zigbee Hub?

Optimal! Sie können unsere Leuchten direkt mit Alexa verbinden.

Votre Alexa a un Hub Zigbee intégré ?

C'est optimal ! Vous pouvez connecter nos luminaires directement à Alexa.

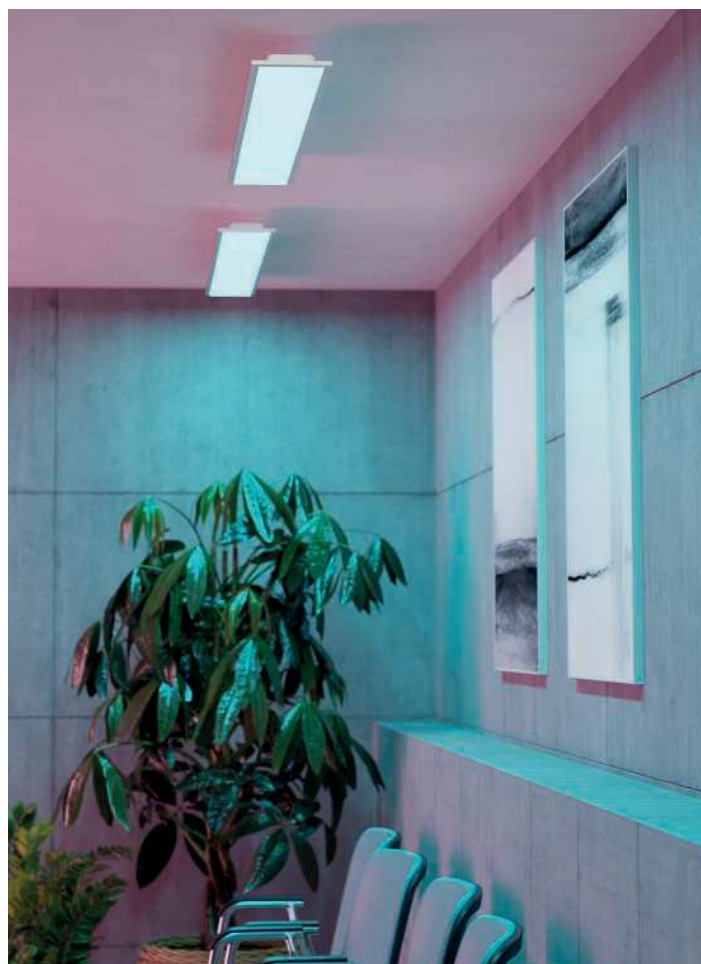

With separate Zigbee Hub

Mit separatem Zigbee Hub

Avec Hub Zigbee séparé



Your Alexa doesn't have an integrated Zigbee hub?

Don't worry! You can simply link an external Zigbee hub from another brand to your Alexa and then connect our luminaires to it.

Ihre Alexa hat keinen integrierten Zigbee Hub?

Keine Sorge! Sie können einfach einen externen Zigbee Hub eines anderen Herstellers mit Ihrer Alexa verknüpfen und dann unsere Leuchten damit verbinden.

Votre Alexa n'a pas de Hub Zigbee intégré ?

Ne vous inquiétez pas ! Vous pouvez simplement relier un hub Zigbee externe d'un autre fabricant à votre Alexa et y connecter ensuite nos luminaires.

* Amazon Alexa and all related marks are trademarks of Amazon.com, Inc. or its affiliates.

WORKS WITH ZIGBEE

Funktioniert mit Zigbee
Fonctionne avec Zigbee

Smart home integration

You already have an existing Zigbee hub or a smart home system based on Zigbee? Perfect! Our luminaires can be integrated into any open Zigbee 3.0 system.

Einbindung Smart Home

Sie haben bereits einen bestehenden Zigbee Hub bzw. ein Smart Home System welches auf Zigbee aufbaut? Optimal! Unsere Leuchten können in jedes offene Zigbee 3.0 System integriert werden.

Intégration de la maison intelligente

Vous avez déjà un Hub Zigbee ou un système Smart Home basé sur Zigbee ? C'est optimal ! Nos luminaires peuvent être intégrés dans n'importe quel système Zigbee 3.0 ouvert.



 **zigbee**

TALKS WITH HOMEY

Kommuniziert mit Homey
Communique avec Homey

Talks with Homey

Do you want more than just control your lighting? Do you want to fully automate your home and have your EGLO luminaires interact in a network with a large number of intelligent devices from a wide range of manufacturers and different wireless standards? With Homey, this becomes a reality.

Kommuniziert mit Homey

Sie streben nach mehr als der Kontrolle über Ihre Beleuchtung? Sie haben den Wunsch, Ihr Zuhause vollständig zu automatisieren und Ihre EGLO Leuchten in einem Netzwerk mit einer Vielzahl von intelligenten Geräten unterschiedlichster Hersteller und verschiedensten Funkstandards interagieren zu lassen? Mit Homey wird genau das zur Realität.

Communique avec Homey

Tu aspires à plus que le contrôle de ton éclairage ? Tu as envie d'automatiser entièrement ta maison et de faire interagir tes luminaires EGLO dans un réseau avec une multitude d'appareils intelligents de différents fabricants et avec les normes radio les plus diverses ? Avec Homey, c'est exactement ce qui devient réalité.





DIMMABLE VIA REMOTE AND APP

All products with this button on the catalogue page can be controlled and dimmed via remote control and app.

Alle Produkte mit diesem Button auf der Katalogseite sind steuerbar und dimmbar über Fernbedienung und App.

Tous les produits avec ce bouton sur la page du catalogue sont contrôlables et gradables via la télécommande et l'application.



99099

99099 CONNECT Z REMOTE

remote control; plastic, grey

Fernbedienung; Kunststoff, grau

Télécommande; plastique, gris

🔌 L 122, B 54, H 18



AAA,
R03P



2 x 1,5V



9002759990992

CONNECT-Z SWITCH

The wall mount can be screwed or glued to smooth surfaces. The switch can be removed from its magnetic holder. The three buttons can be used to access various functions (on-off, dimming, CCT and RGB change).

Die Wandhalterung kann geschraubt oder auf glatte Oberflächen geklebt werden. Der Schalter kann aus seinem Magnethalter entfernt werden. Die drei Tasten können verwendet werden, um auf verschiedene Funktionen zuzugreifen (Ein-, Dimm-, CCT- und RGB-Änderung).

Le support mural peut être vissé ou collé sur des surfaces lisses. L'interrupteur peut être retiré de son support magnétique. Les trois boutons peuvent être utilisés pour accéder à diverses fonctions (changement de déclin, de CCT et de RGB).



900116 CONNECT-Z SWITCH

accessory; plastic, white

Zubehör; Kunststoff, weiss

Accessoires; plastique, blanc

↗ L 80, H 20, A 20



CR2032



9008606285761

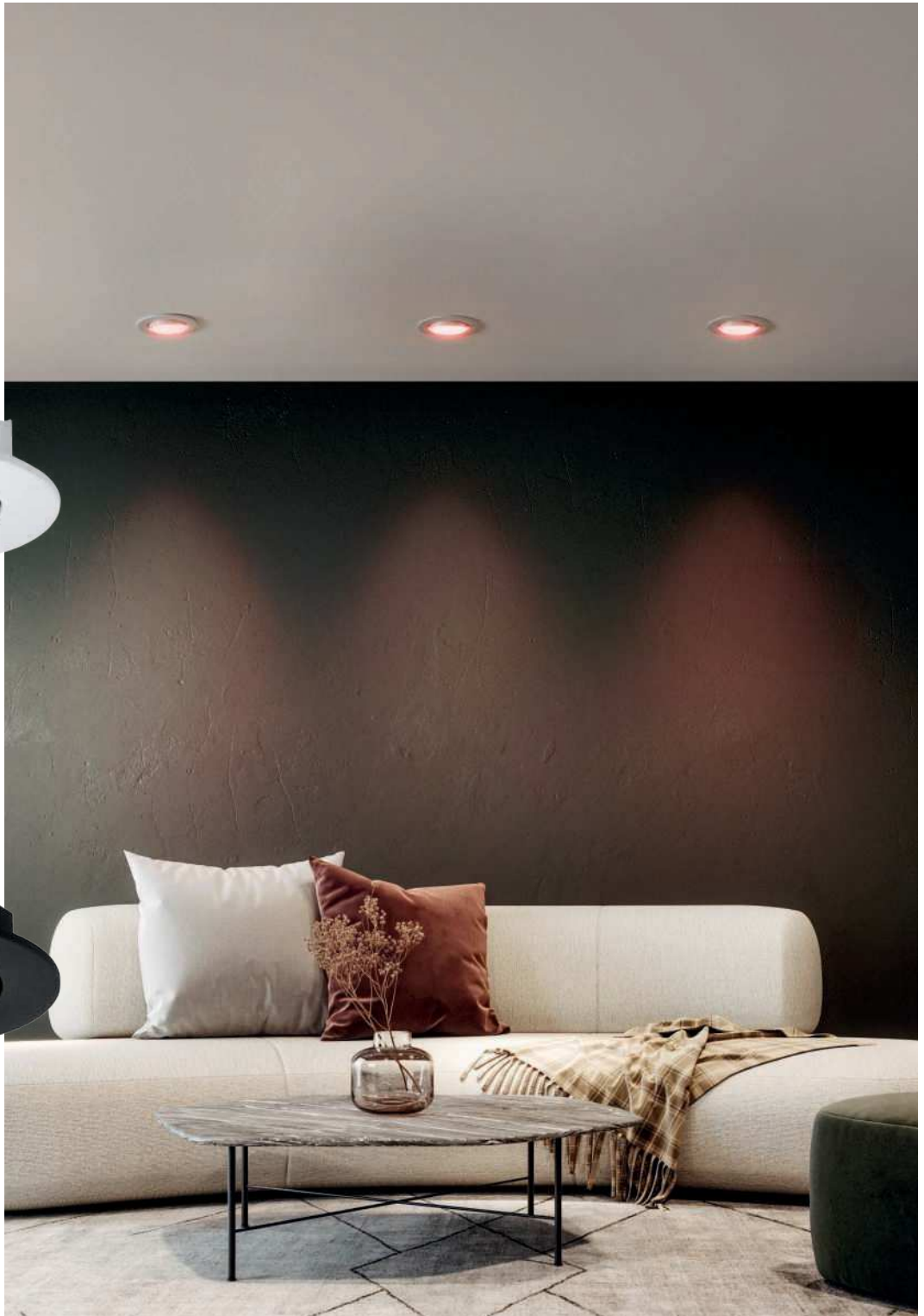

SALICETO-Z

recessed light
Einbauleuchte
luminaire encastrable



Material / Colour	Size	Cutout	Watt	Lumen	Quantity	Material-Nr.	EAN code
aluminium, white Alu, weiss aluminium, blanc	Ø 88, ET 42	Ø 68	4,7 W	440 lm	1	99671	9002759996710
	Ø 88, ET 42	Ø 68	3 x 4,7 W	3 x 1320 lm	3	902286	9008606358953
aluminium, black Alu, schwarz aluminium, noir	Ø 88, ET 42	Ø 68	4,7 W	440 lm	1	99669	9002759996697
	Ø 88, ET 42	Ø 68	3 x 4,7 W	3 x 1320 lm	3	902287	9008606358960

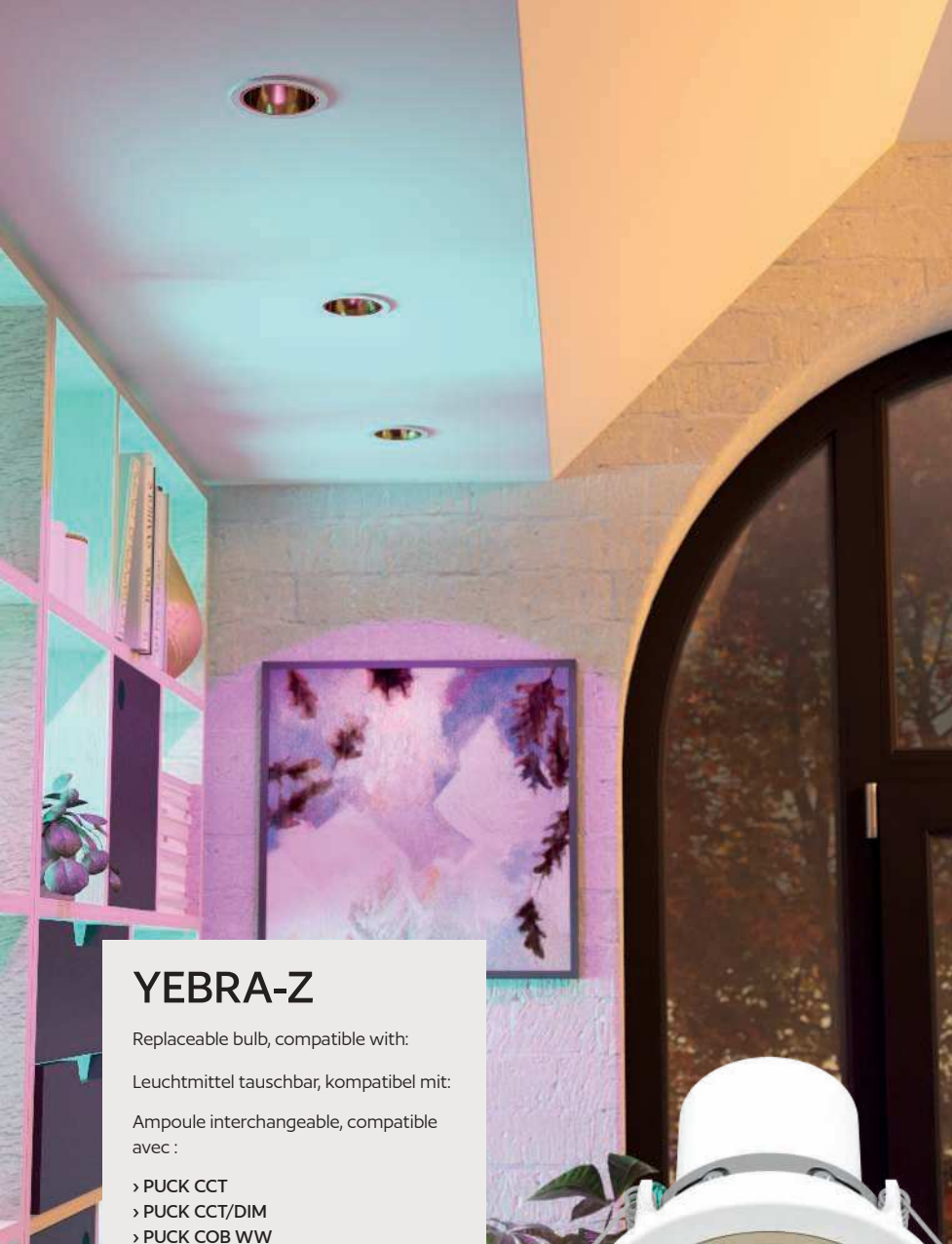

YEBRA-Z

Replaceable bulb, compatible with:

Leuchtmittel tauschbar, kompatibel mit:

Ampoule interchangeable, compatible avec :

- > PUCK CCT
- > PUCK CCT/DIM
- > PUCK COB WW
- > PUCK COB NW
- > PUCK SMART RGB+TW

Learn more on pages 8-9.

Mehr erfahren Sie auf den Seiten 8-9.

En savoir plus aux pages 8-9.

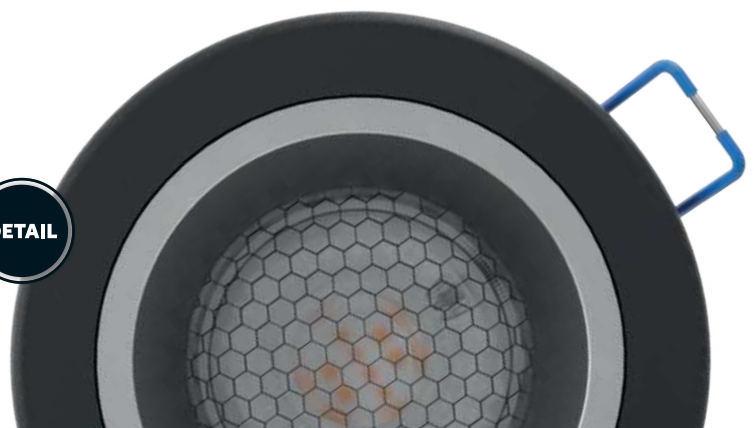

YEBRA-Z

YEBRA-Z luminaires feature a recessed light source and an integrated honeycomb grid for particularly glare-free light beams. The smart LED PUCK modules allow for a shallow installation depth – making them ideal for renovations as well. With a standard cut-out of 68 mm, the spots are perfect for retrofitting. Available in white with a gold trim ring or in black with a silver trim ring. The included honeycomb grid can be easily removed if required.









YEBRA-Z Leuchten punkten mit zurückversetzter Lichtquelle und integriertem Wabengitter für besonders blendfreie Lichtkegel. Die smarten LED PUCK Module ermöglichen eine geringe Einbautiefe – ideal auch für Renovierungen. Mit einem Standard-Ausschnitt von 68 mm eignen sich die Spots perfekt zum Nachrüsten. Erhältlich in Weiß mit goldenem Zierring oder in Schwarz mit silbernem Zierring. Das inkludierte Wabengitter kann bei Bedarf einfach entfernt werden.

Les luminaires YEBRA-Z se distinguent par une source lumineuse en retrait et une grille alvéolée intégrée, offrant des faisceaux lumineux particulièrement peu éblouissants. Les modules LED PUCK intelligents permettent une faible profondeur d'encastrement – idéale également pour les rénovations. Avec une découpe standard de 68 mm, ces spots sont parfaits pour la modernisation ou le remplacement. Disponibles en blanc avec un anneau décoratif doré ou en noir avec un anneau décoratif argenté. La grille alvéolée incluse peut être facilement retirée si nécessaire.

YEBRA-Z

recessed light
Einbauleuchte
luminaire encastrable



Material / Colour	Size	Cutout	Watt	Lumen	Material-Nr.	EAN code
 plastic, white, gold Kunststoff, weiss, gold plastique, blanc, or	Ø 87, ET 61	Ø 68	4,9 W	 490 lm	 Remote, App 902299	 9008606359042
 plastic, black, silver Kunststoff, schwarz, silber plastique, noir, argent	Ø 87, ET 61	Ø 68	4,9 W	 490 lm	 Remote, App 902298	 9008606359035



901168



901168, 901169

Replaceable bulb, compatible with:

Leuchtmittel tauschbar, kompatibel mit:

Ampoule interchangeable, compatible avec :

- > PUCK CCT
- > PUCK CCT/DIM
- > PUCK COB WW
- > PUCK COB NW
- > PUCK SMART RGB+TW

Learn more on pages 8-9.

Mehr erfahren Sie auf den Seiten 8-9.

En savoir plus aux pages 8-9.



901169

CAROSSO-Z

The unique selling point of this products is its slightly recessed light source, which reduces glare from the side while the acrylic ring creates a distinctive lighting effect, enhancing the design stylishly.

Das besondere Merkmal dieser Produkte ist das leicht zurückgesetzte Leuchtmittel, das seitliche Blendung reduziert. Gleichzeitig sorgt der Acrylring für einen einzigartigen Lichteffect, der das Design stilvoll unterstreicht.

L'atout principal de ces produits est sa source lumineuse légèrement en retrait, ce qui réduit l'éblouissement latéral. Dans le même temps, l'anneau en acrylique crée un effet lumineux distinctif qui sublime le design avec élégance.



901168 CAROSSO-Z

surface-mounted light; aluminium, black / plastic, white

Aufbauleuchte; Alu, schwarz / Kunststoff, weiss

luminaire en saillie; aluminium, noir / plastique, blanc

H 120, Ø 80



GU10



1 x
4,9 W



1 x
345 lm



Remote,
App



9008606312900



901169 CAROSSO-Z

surface-mounted light; aluminium, white / plastic, white

Aufbauleuchte; Alu, weiss / Kunststoff, weiss

luminaire en saillie; aluminium, blanc / plastique, blanc

H 120, Ø 80



GU10



1 x
4,9 W



1 x
345 lm



Remote,
App



9008606312917





900764



900766



900763



900765



900764 CAROSSO-Z

recessed light; aluminium, black / plastic, white

Einbauleuchte; Alu, schwarz / Kunststoff, weiss

luminaire encastrable; aluminium, noir / plastique, blanc

∩ Ø 93, ET 70

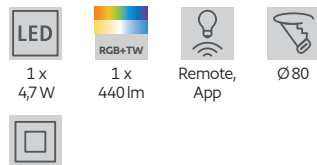

9008606259809

900766 CAROSSO-Z

recessed light; aluminium, white / plastic, white

Einbauleuchte; Alu, weiss / Kunststoff, weiss

luminaire encastrable; aluminium, blanc / plastique, blanc

∩ Ø 93, ET 70

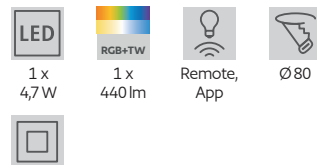

9008606259823

900763 CAROSSO-Z

recessed light; aluminium, black / plastic, white

Einbauleuchte; Alu, schwarz / Kunststoff, weiss

luminaire encastrable; aluminium, noir / plastique, blanc

∩ L 93, B 93, ET 70

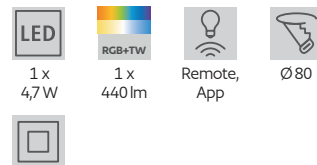

9008606259793

900765 CAROSSO-Z

recessed light; aluminium, white / plastic, white

Einbauleuchte; Alu, weiss / Kunststoff, weiss

luminaire encastrable; aluminium, blanc / plastique, blanc

∩ L 93, B 93, ET 70

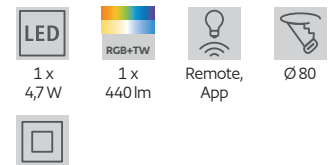

9008606259816

FUEVA 6-Z

For bright light while working or atmospheric lighting with dimmable RGB CCT effects – ideal for DIY projects with suspended ceilings. Thanks to its ultra-slim installation depth, it is perfect for retrofitting existing recessed spotlights with a 75 mm cutout, up to larger, high-performance models. The luminaires are available in white, matt black and satin nickel - also ideal for ceiling mounting in the bathroom thanks to IP44.

Für helles Licht beim Arbeiten oder stimmungsvolle Beleuchtung mit dimmbaren RGB CCT-Effekten – ideal für DIY-Projekte mit abgehängten Decken. Dank der besonders flachen Einbautiefe perfekt zur Nachrüstung bestehender Einbauspotlights mit 75 mm Ausschnitt bis hin zu größeren, leistungsstarken Modellen. Die Leuchten sind erhältlich in Weiß, Schwarz und Nickel matt – dank IP44 auch ideal für die Deckenmontage im Badezimmer geeignet.

Pour une lumière vive lors du travail ou un éclairage d'ambiance avec des effets RGB CCT dimmables – idéal pour les projets DIY avec des plafonds suspendus. Grâce à sa profondeur d'encastrement ultra-mince, il est parfait pour moderniser des spots encastrés existants avec une découpe de 75 mm, jusqu'à des modèles plus grands et performants. Les luminaires sont disponibles en blanc, noir et nickel mat - grâce à l'IP44, ils sont également idéaux pour une installation au plafond dans la salle de bain.

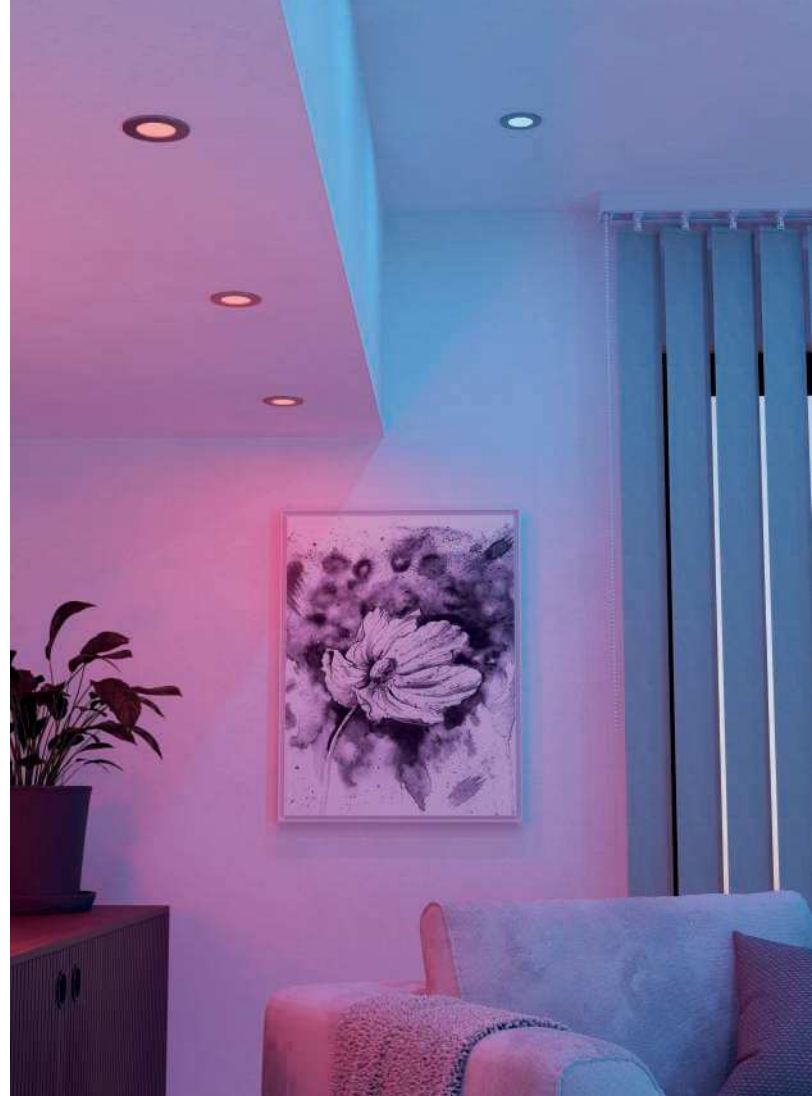

FUEVA 6-Z

recessed light
Einbauleuchte
luminaire encastrable



Material / Colour	Size	Cutout	Watt	Lumen	IP class	Quantity	Material-Nr.	EAN code
plastic, white / plastic, white Kunststoff, weiss / Kunststoff, weiss plastique, blanc / plastique, blanc	Ø 88, ET 40	Ø 75	3 x 2,8 W	3 x 340 lm	Remote, App	3	901429	9008606330997
	Ø 120, ET 40	Ø 105	5 W	620 lm	Remote, App	1	901431	9008606331000
	Ø 168, ET 40	Ø 155	9,5 W	1150 lm	Remote, App	1	901432	9008606331017
plastic, satin nickel / plastic, white Kunststoff, nickel-matt / Kunststoff, weiss plastique, nickel mat / plastique, blanc	Ø 88, ET 40	Ø 75	3 x 2,8 W	3 x 340 lm	Remote, App	3	901434	9008606331024
	Ø 120, ET 40	Ø 105	5 W	620 lm	Remote, App	1	901435	9008606331031
	Ø 168, ET 40	Ø 155	9,5 W	1150 lm	Remote, App	1	901436	9008606331048
plastic, black / plastic, white Kunststoff, schwarz / Kunststoff, weiss plastique, noir / plastique, blanc	Ø 88, ET 40	Ø 75	3 x 2,8 W	3 x 340 lm	Remote, App	3	901425	9008606330966
	Ø 120, ET 40	Ø 105	5 W	620 lm	Remote, App	1	901426	9008606330973
	Ø 168, ET 40	Ø 155	9,5 W	1150 lm	Remote, App	1	901427	9008606330980

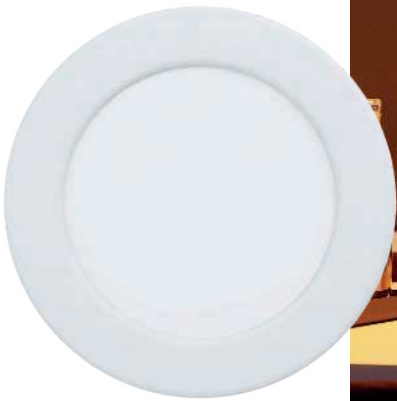

FUEVA 6-Z

With a mounting height of just 25 mm, this ceiling luminaires blend discreetly into any interior design concept. The smaller models (from 1,400 lumens) are often used in multiples, while the larger versions (up to 2,850 lumens) provide powerful, even illumination on their own. Thanks to RGB CCT technology, cosy warm white, bright cool white and playful RGB effects can be set. With an IP44 rating, they are also suitable for the bathroom - available in black, white or satin nickel.

Mit nur 25 mm Aufbauhöhe fügen sich diese Deckenleuchten dezent in jedes Raumkonzept ein. Die kleineren Modelle (ab 1.400 Lumen) werden oft mehrfach eingesetzt, während die größeren Varianten (bis 2.850 Lumen) auch einzeln eine kraftvolle, gleichmäßige Ausleuchtung bieten. Dank RGB CCT-Technologie lassen sich sowohl gemütliches Warmweiß, helles Kaltweiß und verspielte RGB-Effekte einstellen. Mit IP44 sind sie auch für das Badezimmer geeignet - erhältlich in Schwarz, Weiß oder Nickel matt.

Avec une hauteur d'installation de seulement 25 mm, ces plafonniers s'intègrent discrètement dans n'importe quel concept d'espace. Les modèles plus petits (à partir de 1 400 lumens) sont souvent utilisés en plusieurs exemplaires, tandis que les versions plus grandes (jusqu'à 2 850 lumens) offrent un éclairage puissant et homogène même seules. Grâce à la technologie RGB CCT, il est possible de régler aussi bien un blanc chaud confortable qu'un blanc froid lumineux ou des effets RGB ludiques. Avec IP44, elles sont également adaptées à la salle de bain - disponibles en noir, blanc ou nickel mat.



FUEVA 6-Z

surface-mounted light
Aufbauleuchte
luminaire en saillie









































Material / Colour	Size	Watt	Lumen	IP class	Material-Nr.	EAN code
plastic, white / plastic, white Kunststoff, weiss / Kunststoff, weiss plastique, blanc / plastique, blanc	H 25, Ø 211	11,2 W	1400 lm	Remote, App, IP44	901376	9008606330546
	H 25, Ø 278	14,3 W	1800 lm	Remote, App, IP44	901377	9008606330553
	H 25, Ø 389	17,5 W	2850 lm	Remote, App, IP44	901726	9008606330560
steel, satin nickel / plastic, white Stahl, nickel-matt / Kunststoff, weiss acier, nickel mat / plastique, blanc	H 25, Ø 211	11,2 W	1400 lm	Remote, App, IP44	901381	9008606330607
	H 25, Ø 278	14,3 W	1800 lm	Remote, App, IP44	901382	9008606330614
	H 25, Ø 389	17,5 W	2850 lm	Remote, App, IP44	901421	9008606354085
plastic, black / plastic, white Kunststoff, schwarz / Kunststoff, weiss plastique, noir / plastique, blanc	H 25, Ø 211	11,2 W	1400 lm	Remote, App, IP44	901372	9008606330485
	H 25, Ø 278	14,3 W	1800 lm	Remote, App, IP44	901373	9008606330492
	H 25, Ø 389	17,5 W	2850 lm	Remote, App, IP44	901725	9008606330508



FUEVA 6-Z

surface-mounted light
Aufbauleuchte
luminaire en saillie



Material / Colour	Size	Watt		Lumen		IP class	Material-Nr.	EAN code
 plastic, white / plastic, white Kunststoff, weiss / Kunststoff, weiss plastique, blanc / plastique, blanc	L 220, B 220, H 25	10,5 W		1600 lm	 Remote, App	 IP44	901378	 9008606330577
	L 295, B 295, H 25	13,5 W		2000 lm	 Remote, App	 IP44	901379	 9008606330584
	L 390, B 390, H 25	17,8 W		2700 lm	 Remote, App	 IP44	901729	 9008606330591
 steel, satin nickel / plastic, white Stahl, nickel-matt / Kunststoff, weiss acier, nickel mat / plastique, blanc	L 220, B 220, H 25	10,5 W		1600 lm	 Remote, App	 IP44	901383	 9008606330638
	L 295, B 295, H 25	13,5 W		2000 lm	 Remote, App	 IP44	901384	 9008606330645
	L 390, B 390, H 25	17,8 W		2700 lm	 Remote, App	 IP44	901422	 9008606354092
 plastic, black / plastic, white Kunststoff, schwarz / Kunststoff, weiss plastique, noir / plastique, blanc	L 220, B 220, H 25	10,5 W		1600 lm	 Remote, App	 IP44	901374	 9008606330515
	L 295, B 295, H 25	13,5 W		2000 lm	 Remote, App	 IP44	901375	 9008606330522
	L 390, B 390, H 25	17,8 W		2700 lm	 Remote, App	 IP44	901728	 9008606330539

MELITELLO-Z

These modern spots with adjustable heads combine elegant aluminium with matte acrylic rings – a true design highlight! The rings not only provide focused light but also diffuse it softly throughout the room. Once connected via remote control or app, the luminaires can be conveniently operated.

Diese modernen Spots mit schwenkbaren Köpfen kombinieren elegantes Aluminium mit matten Acrylringen – ein echtes Design-Highlight! Die Ringe sorgen nicht nur für fokussiertes Licht, sondern streuen es zusätzlich weich in den Raum. Einmal per Fernbedienung oder App verbunden, lassen sich die Leuchten bequem steuern.

Ces spots modernes avec têtes orientables allient un aluminium élégant à des anneaux en acrylique mat – un véritable atout design ! Les anneaux offrent non seulement une lumière ciblée, mais la diffusent également en douceur dans la pièce. Une fois connectés via télécommande ou application, les luminaires se commandent facilement.



901943 MELITELLO-Z

spot; aluminium, steel, white
Spot; Alu, Stahl, weiss
spot; aluminium, acier, blanc

L 250, B 105, H 80

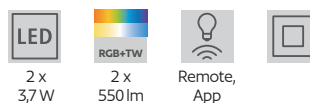

901944 MELITELLO-Z

spot; aluminium, steel, white
Spot; Alu, Stahl, weiss
spot; aluminium, acier, blanc

L 680, B 105, H 80

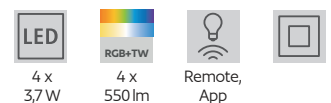

9008606358144



9008606358151



901941



901942

901941 MELITELLO-Z

spot; aluminium, steel, black
Spot; Alu, Stahl, schwarz
spot; aluminium, acier, noir

↕ L 250, B 105, H 80



2 x
3,7 W



2 x
550 lm



Remote,
App



901942 MELITELLO-Z

spot; aluminium, steel, black
Spot; Alu, Stahl, schwarz
spot; aluminium, acier, noir

↕ L 680, B 105, H 80



4 x
3,7 W



4 x
550 lm



Remote,
App



9008606358120



9008606358137

SANIA-Z

Whether on living room walls or in hallways - these elegant wall luminaires made of high-quality, powder-coated aluminium provide pleasant, indirect light indoors. Thanks to IP55 protection, they are also ideal for outdoor use: on façades, house entrances or on the patio, they create stylish accents with their striking up & down lighting effect. They are available in black or white - rust-free, durable and versatile.

Ob an Wohnwänden oder in Fluren – diese eleganten Wandleuchten aus hochwertigem, pulverbeschichtetem Aluminium sorgen drinnen für angenehmes, indirektes Licht. Dank IP55-Schutz sind sie aber auch ideal für den Außenbereich: an Fassaden, Hauseingängen oder auf der Terrasse setzen sie mit ihrem markanten Up-&-Down-Lichteffekt stilvolle Akzente. Sie sind erhältlich in Schwarz oder Weiß – rostfrei, langlebig und vielseitig einsetzbar.

Que ce soit sur les murs du salon ou dans les couloirs, ces élégantes appliques murales en aluminium thermo-laqué de haute qualité assurent une lumière indirecte agréable à l'intérieur. Mais grâce à leur protection IP55, elles sont également idéales pour l'extérieur : sur les façades, les entrées de maison ou sur la terrasse, elles apportent une touche de style avec leur effet lumineux up-&-down marquant. Elles sont disponibles en noir ou en blanc - inoxydables, durables et polyvalentes.

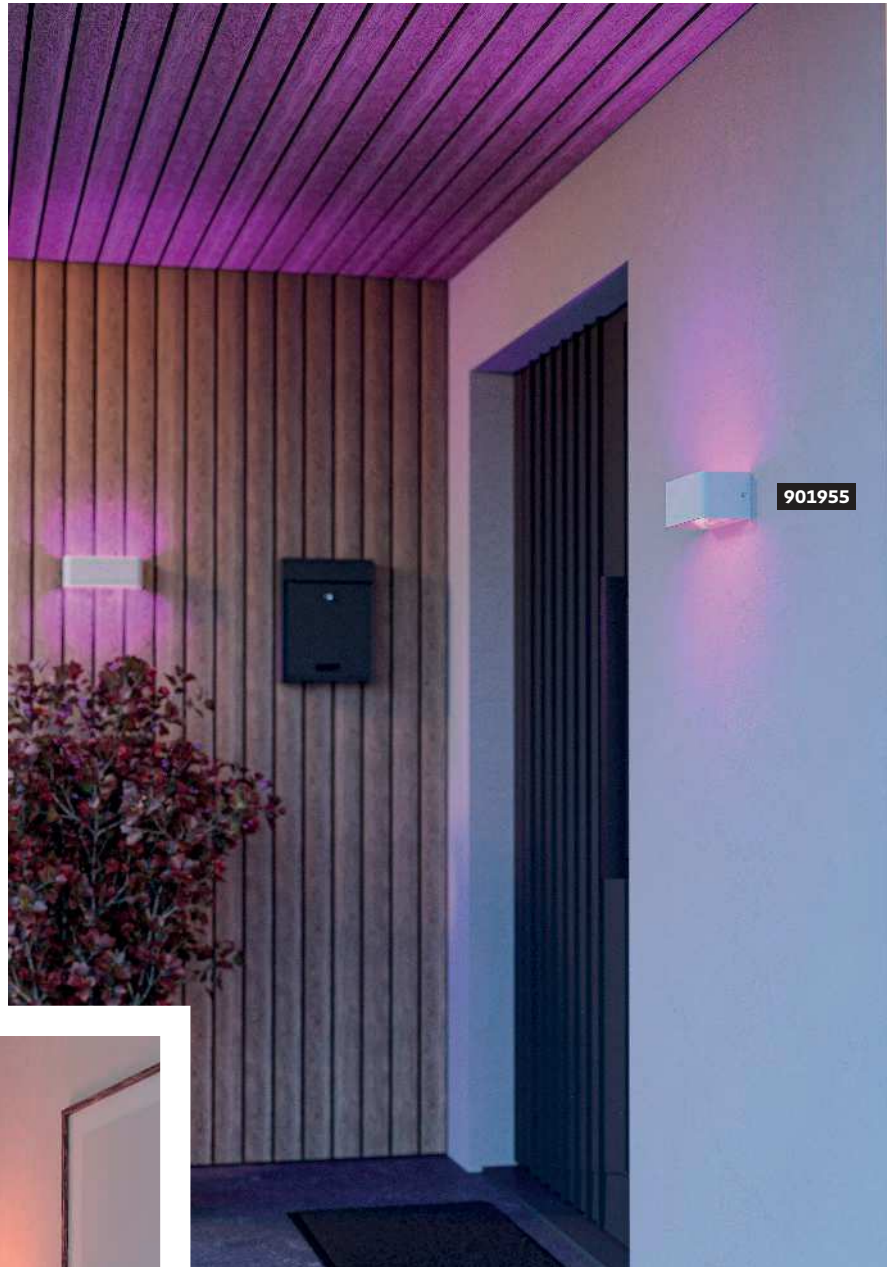

901955 SANIA-Z

wall light; aluminium, steel, white / plastic, white

Wandleuchte; Alu, Stahl, weiss / Kunststoff, weiss

Applique; aluminium, acier, blanc / plastique, blanc

↳ L 200, H 80, A 90



1 x
10 W



1 x
1180 lm



Remote,
App



IP55



9008606361663

901956 SANIA-Z

wall light; aluminium, steel, black / plastic, white

Wandleuchte; Alu, Stahl, schwarz / Kunststoff, weiss

Applique; aluminium, acier, noir / plastique, blanc

↳ L 200, H 80, A 90



1 x
10 W



1 x
1180 lm



Remote,
App



IP55



9008606361670

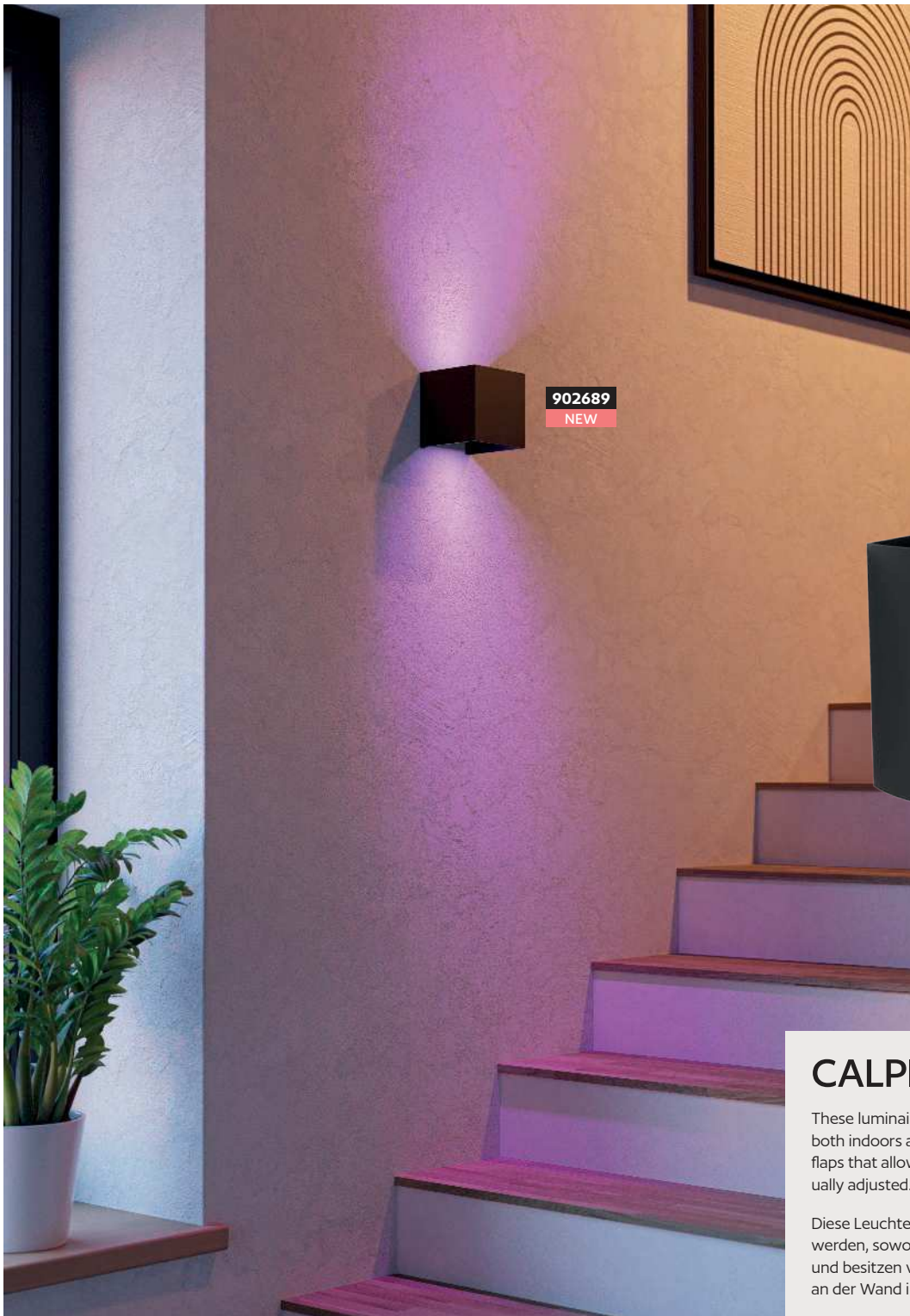

902689
NEW



902659
NEW

902689 CALPINO-Z

wall light; aluminium, plastic, black matt / glass, clear

Wandleuchte; Alu, Kunststoff, schwarz-matt / Glas, klar

Applique; aluminium, plastique, noir mat / verre, transparent

↻ L 110, H 110, A 112



2 x
3,5 W



2 x
300 lm



Remote,
App



IP55



902659 CALPINO-Z

wall light; aluminium, plastic, black matt / glass, clear

Wandleuchte; Alu, Kunststoff, schwarz-matt / Glas, klar

Applique; aluminium, plastique, noir mat / verre, transparent

↻ L 150, H 130, A 130



2 x
3,5 W



2 x
300 lm



Remote,
App



IP55



9008606396931



9008606390359

CALPINO-Z

These luminaires can be used in a multifunctional way, both indoors and outdoors, and feature adjustable flaps that allow the light cast on the wall to be individually adjusted.

Diese Leuchten können multifunktionell eingesetzt werden, sowohl im Innen- als auch im Außenbereich und besitzen verstellbare Klappen, um den Lichtschein an der Wand individuell anzupassen.

Ces luminaires peuvent être utilisés de manière polyvalente, aussi bien à l'intérieur qu'à l'extérieur, et sont dotés de volets réglables permettant d'adapter individuellement le faisceau lumineux sur le mur.



GALLIZZI-Z

These minimalist, round ceiling luminaires with a flat installation height of just 70 mm blend unobtrusively into any room. Available in three sizes and with black or white trim, they offer the right variant for every room concept. Thanks to smart control, the light can be adjusted from bright to pleasantly dimmed, also in RGB colours. Their clear form and versatile lighting make these luminaires the ideal choice for modern living spaces.

Diese minimalistischen, runden Deckenleuchten mit einer flachen Aufbauhöhe von nur 70 mm fügen sich unauffällig in jeden Raum ein. In drei Größen und mit schwarzem oder weißem Rand erhältlich, bieten sie für jedes Raumkonzept die passende Variante. Dank smarter Steuerung lässt sich das Licht von hell bis angenehm gedimmt einstellen, auch in RGB-Farben. Ihre klare Form und vielseitige Beleuchtung machen diese Leuchten zur idealen Wahl für moderne Wohnräume.

Ces plafonniers ronds et minimalistes, avec une hauteur de montage de seulement 70 mm, s'intègrent discrètement dans chaque pièce. Disponibles en trois tailles et avec un bord noir ou blanc, ils offrent une variante adaptée à chaque concept de pièce. Grâce à une commande intelligente, la lumière peut être réglée de claire à agréablement tamisée, également dans des couleurs RGB. Leur forme claire et leur éclairage polyvalent font de ces luminaires le choix idéal pour les espaces de vie modernes.

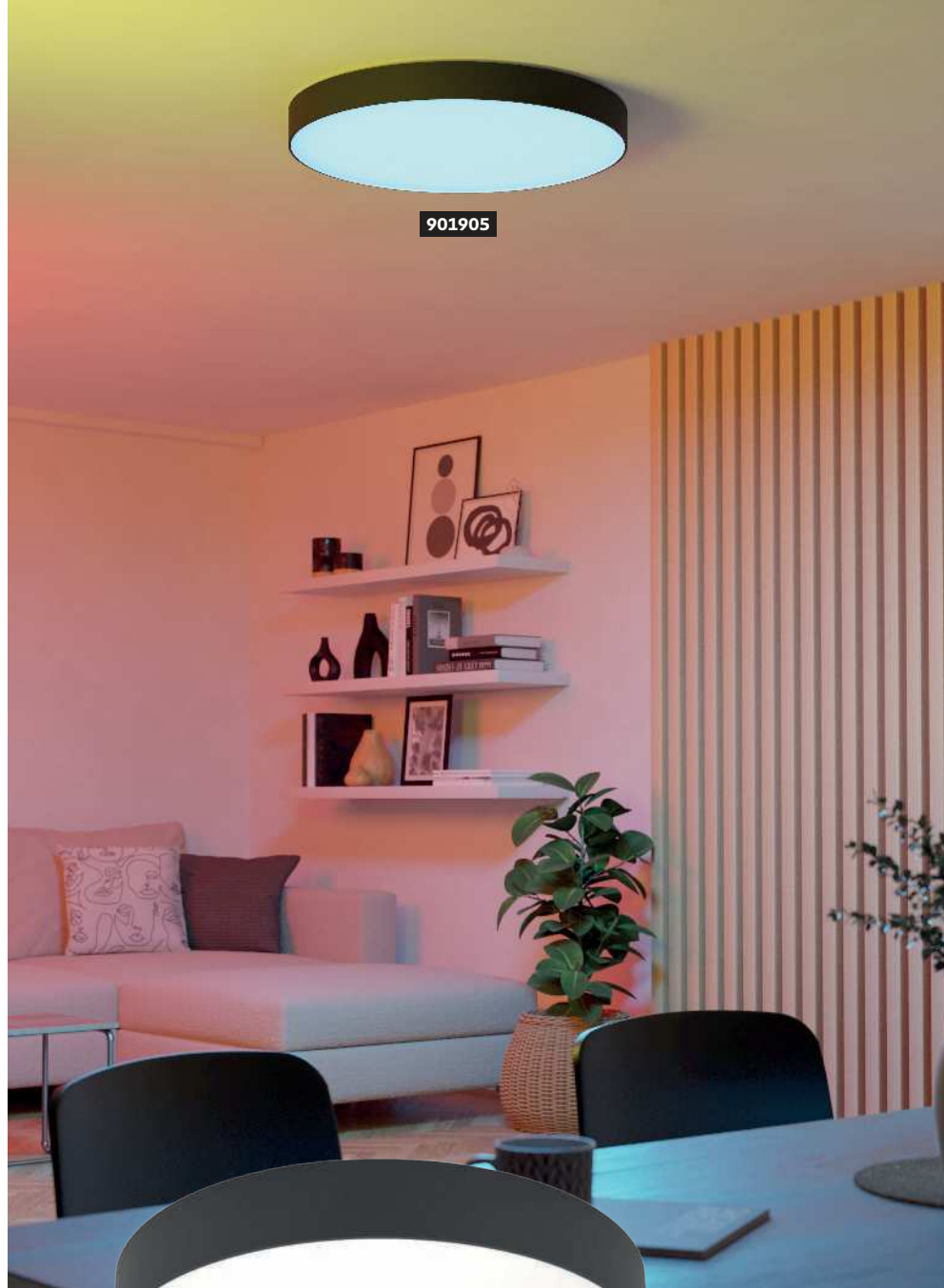

901905



901903



901904

901905 GALLIZZI-Z

ceiling light; plastic, black / plastic, white
Deckenleuchte; Kunststoff, schwarz / Kunststoff, weiss
plafonnier; plastique, noir / plastique, blanc

↕ H 70, Ø 690



1 x
36,5 W



1 x
5300 lm



Remote,
App



9008606358182

901903 GALLIZZI-Z

ceiling light; plastic, black / plastic, white
Deckenleuchte; Kunststoff, schwarz / Kunststoff, weiss
plafonnier; plastique, noir / plastique, blanc

↕ H 70, Ø 390



1 x
15 W



1 x
1900 lm



Remote,
App



9008606358168

901904 GALLIZZI-Z

ceiling light; plastic, black / plastic, white
Deckenleuchte; Kunststoff, schwarz / Kunststoff, weiss
plafonnier; plastique, noir / plastique, blanc

↕ H 70, Ø 490



1 x
26 W



1 x
3500 lm



Remote,
App



9008606358175

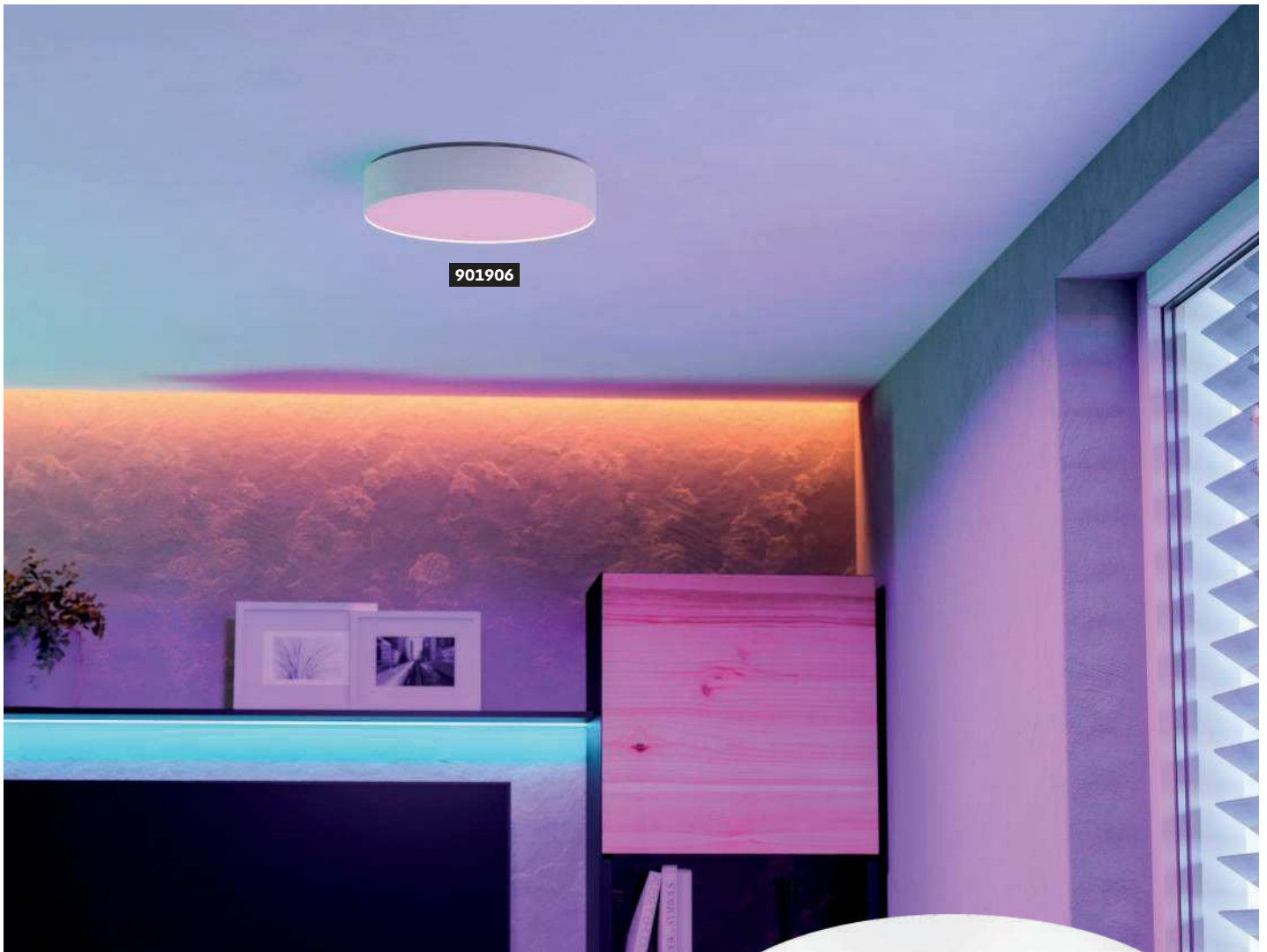

901906



901907



901908

901906 GALLIZZI-Z

ceiling light; plastic, white / plastic, white
 Deckenleuchte; Kunststoff, weiss / Kunststoff, weiss
 plafonnier; plastique, blanc / plastique, blanc

↕ H 70, Ø 390



1 x
15 W



1 x
1900 lm



Remote,
App



901907 GALLIZZI-Z

ceiling light; plastic, white / plastic, white
 Deckenleuchte; Kunststoff, weiss / Kunststoff, weiss
 plafonnier; plastique, blanc / plastique, blanc

↕ H 70, Ø 490



1 x
26 W



1 x
3500 lm



Remote,
App

901908 GALLIZZI-Z

ceiling light; plastic, white / plastic, white
 Deckenleuchte; Kunststoff, weiss / Kunststoff, weiss
 plafonnier; plastique, blanc / plastique, blanc

↕ H 70, Ø 690



1 x
36,5 W



1 x
5300 lm



Remote,
App



9008606358199



9008606358205



9008606358212

TURCONA-Z

The TURCONA-Z series impresses with its frameless design, which creates a particularly clear and purist look. The seamless design allows the luminaires to blend harmoniously into any surroundings and create an elegant, floating lighting effect. The TURCONA-Z combines aesthetics and functionality at the highest level.

Die Leuchtenserie TURCONA-Z begeistert mit ihrem rahmenlosen Design, das für eine besonders klare und puristische Optik sorgt. Durch die nahtlose Gestaltung fügen sich die Leuchten harmonisch in jede Umgebung ein und schaffen eine elegante, schwebende Lichtwirkung. Die TURCONA-Z vereint Ästhetik und Funktionalität auf höchstem Niveau.

La série de luminaires TURCONA-Z séduit par son design sans cadre qui lui confère un aspect particulièrement clair et épuré. Grâce à leur conception sans raccords, les luminaires s'intègrent harmonieusement dans chaque environnement et créent un effet lumineux élégant et flottant. Le TURCONA-Z allie esthétique et fonctionnalité au plus haut niveau.

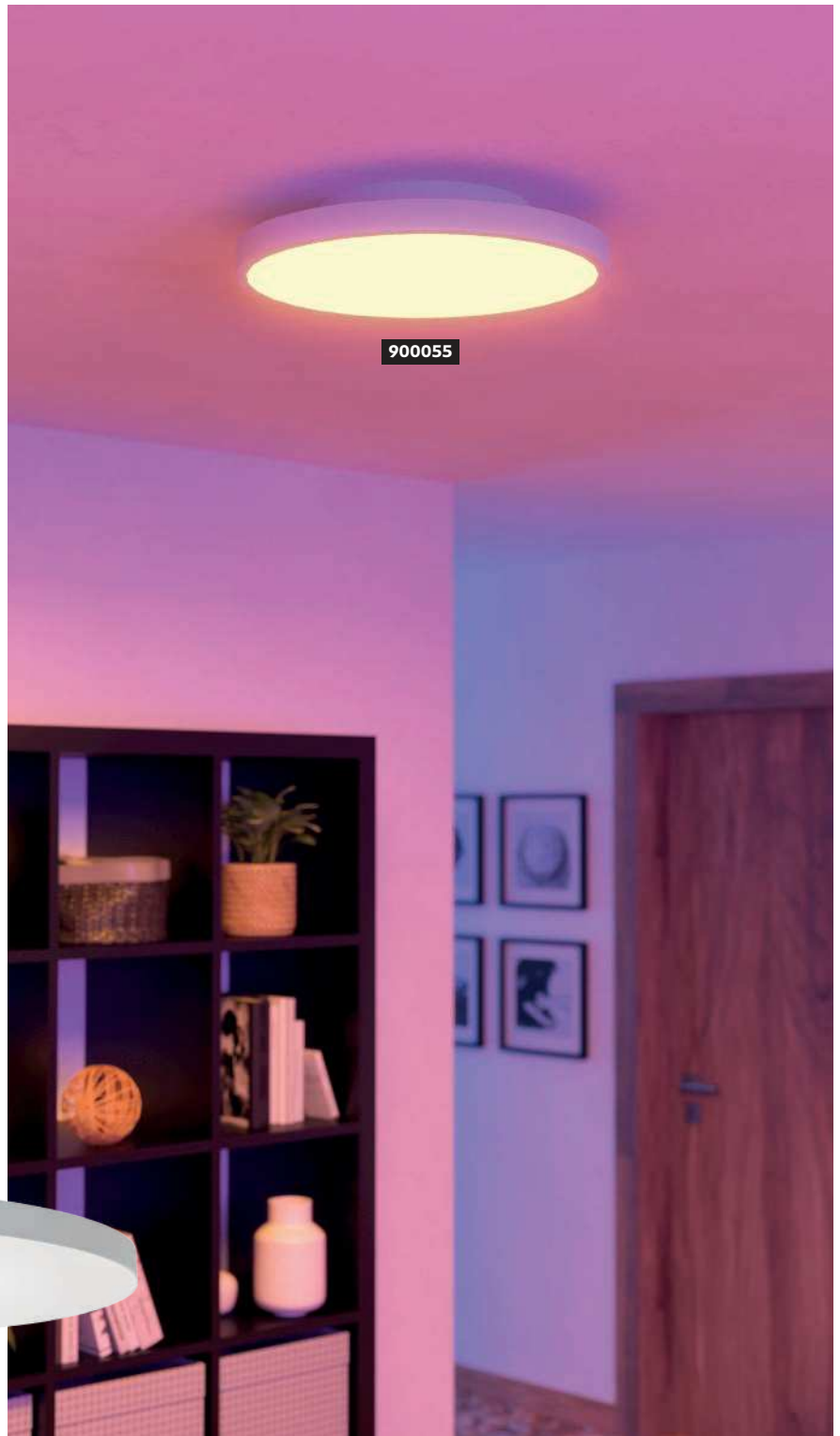

900054



900056



900054 TURCONA-Z

ceiling light; steel, aluminium, white / plastic, white

Deckenleuchte; Stahl, Alu, weiss / Kunststoff, weiss

plafonnier; acier, aluminium, blanc / plastique, blanc

↕ H 60, Ø 300



1 x
15,7 W



1 x
1730 lm



Remote,
App



900055 TURCONA-Z

ceiling light; steel, aluminium, white / plastic, white

Deckenleuchte; Stahl, Alu, weiss / Kunststoff, weiss

plafonnier; acier, aluminium, blanc / plastique, blanc

↕ H 75, Ø 450



1 x
22,4 W



1 x
2490 lm



Remote,
App



900056 TURCONA-Z

ceiling light; steel, aluminium, white / plastic, white

Deckenleuchte; Stahl, Alu, weiss / Kunststoff, weiss

plafonnier; acier, aluminium, blanc / plastique, blanc

↕ H 75, Ø 600



1 x
34,2 W



1 x
3980 lm



Remote,
App



9008606221905



9008606221912



9008606221929

SARSINA-Z

These ceiling luminaires are among the brightest in our range, providing powerful and uniform illumination with 4,300 lumens (Ø 450 mm) and 5,800 lumens (Ø 600 mm). They offer warm white and cool white light and can be dimmed seamlessly via remote control, app, or smart home system. Without RGB functions, they focus purely on brightness and flexibility - perfect for workspaces, kitchens, or wardrobes that require clear, intense lighting.

Diese Deckenleuchten gehören zu den hellsten in unserem Sortiment und bieten mit 4.300 Lumen (Ø 450 mm) bzw. 5.800 Lumen (Ø 600 mm) eine starke, gleichmäßige Beleuchtung. Sie bieten Warmweiß- und Kaltweißlicht und können über eine Fernbedienung, App oder Smart Home System stufenlos heruntergedimmt werden. Ohne RGB-Funktionen konzentrieren sie sich auf reine Helligkeit und Flexibilität - perfekt für Arbeitsräume, Küchen oder Garderoben, die eine klare, intensive Beleuchtung benötigen.

Ces plafonniers comptent parmi les plus lumineux de notre gamme, offrant un éclairage puissant et homogène avec 4 300 lumens (Ø 450 mm) et 5 800 lumens (Ø 600 mm). Ils proposent une lumière blanche chaude et froide et peuvent être atténués en continu via une télécommande, une application ou un système domotique. Sans fonctions RGB, ils se concentrent uniquement sur la luminosité et la flexibilité - parfaits pour les espaces de travail, les cuisines ou les garde-robes nécessitant un éclairage clair et intense.



900762

900758

900761

900759

900762 SARSINA-Z

ceiling light; aluminium, steel, black / plastic, white

Deckenleuchte; Alu, Stahl, schwarz / Kunststoff, weiss

plafonnier; aluminium, acier, noir / plastique, blanc

H 52, Ø 600



1 x 41 W
1 x 5800 lm
Remote, App

900761 SARSINA-Z

ceiling light; aluminium, steel, black / plastic, white

Deckenleuchte; Alu, Stahl, schwarz / Kunststoff, weiss

plafonnier; aluminium, acier, noir / plastique, blanc

H 52, Ø 450



1 x 33,5 W
1 x 4300 lm
Remote, App

900758 SARSINA-Z

ceiling light; aluminium, steel, white / plastic, white

Deckenleuchte; Alu, Stahl, weiss / Kunststoff, weiss

plafonnier; aluminium, acier, blanc / plastique, blanc

H 52, Ø 450



1 x 33,5 W
1 x 4300 lm
Remote, App

900759 SARSINA-Z

ceiling light; aluminium, steel, white / plastic, white

Deckenleuchte; Alu, Stahl, weiss / Kunststoff, weiss

plafonnier; aluminium, acier, blanc / plastique, blanc

H 52, Ø 600



1 x 41 W
1 x 5800 lm
Remote, App



9008606264070



9008606264063



9008606264049



9008606264056



900483



900481

PADROGIANO-Z

The frame of these luminaires can switch between RGB colour tones, while the inner part can reproduce different shades of white between 2700K and 6500K. Customised lighting effects can be set using an app or remote control. Both the frame and the inner part can be switched on and off and dimmed separately.

Der Rahmen dieser Leuchten kann zwischen den RGB Farbtönen wechseln, der Innenteil kann verschiedene Weißtöne zwischen 2700K und 6500K wiedergeben. Durch Steuerung per App oder Fernbedienung können so individuelle Lichtspiele eingestellt werden. Sowohl der Rahmen als auch der Innenteil können separat ein- und ausgeschaltet sowie gedimmt werden.

Le cadre de ces luminaires peut changer de teinte RGB, la partie intérieure peut reproduire différentes nuances de blanc entre 2700K et 6500K. Il est ainsi possible de régler des jeux de lumière individuels en les commandant via une application ou une télécommande. Le cadre et la partie intérieure peuvent tous deux être allumés et éteints séparément et leur intensité peut être réglée.

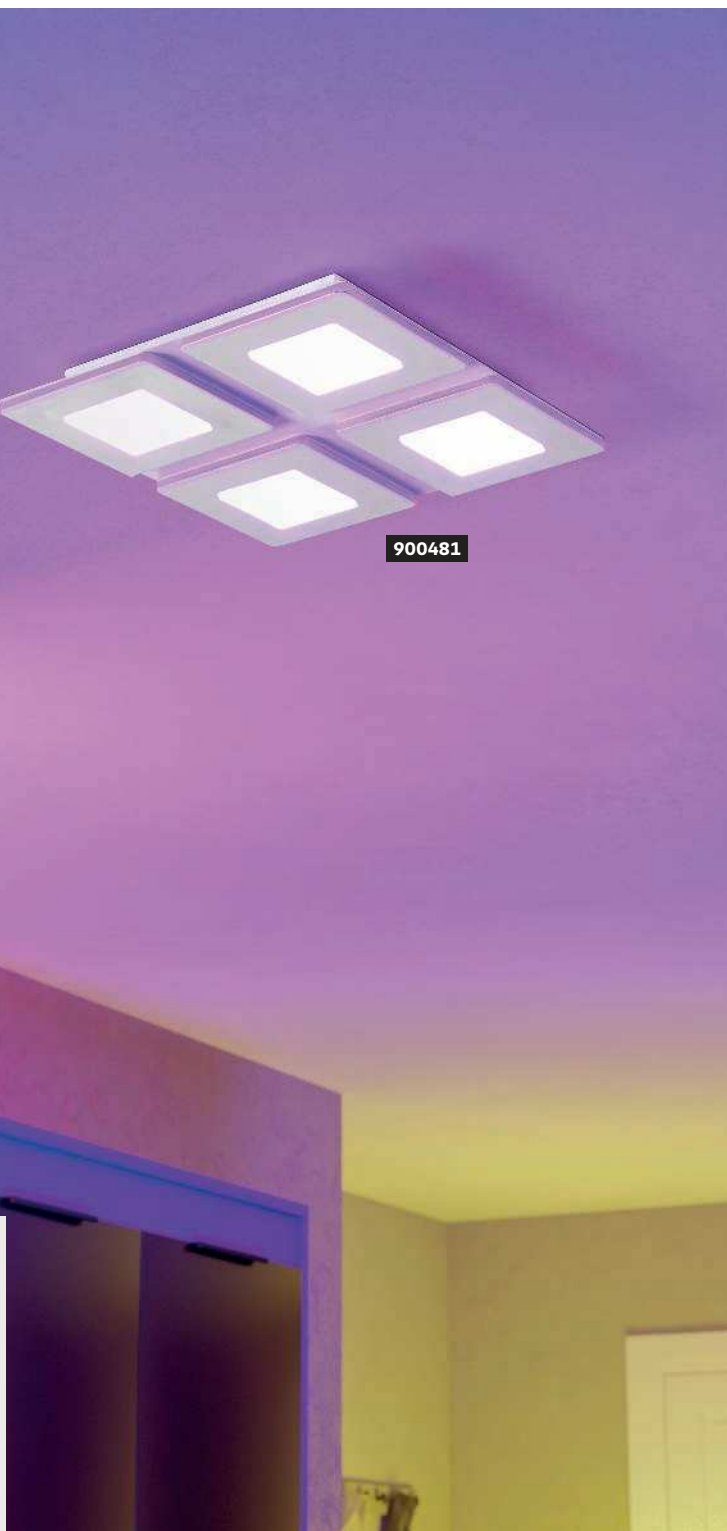

900483 PADROGIANO-Z

ceiling light; steel, white / plastic, white
Deckenleuchte; Stahl, weiss / Kunststoff, weiss
plafonnier; acier, blanc / plastique, blanc

L 450, B 450, H 50



3 x
9,7 W



3 x
1170 lm



Remote,
App



900481 PADROGIANO-Z

ceiling light; steel, white / plastic, white
Deckenleuchte; Stahl, weiss / Kunststoff, weiss
plafonnier; acier, blanc / plastique, blanc

L 450, B 450, H 50



4 x
9,7 W



4 x
1170 lm



Remote,
App



9008606244188



9008606244164



900485



900484



900482

900485 PADROGIANO-Z

ceiling light; steel, white / plastic, white
Deckenleuchte; Stahl, weiss / Kunststoff, weiss
plafonnier; acier, blanc / plastique, blanc

↕ L 1200, B 300, H 50

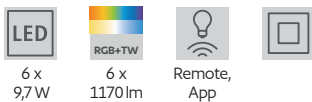

6 x 9,7 W
6 x 1170 lm
Remote, App

900484 PADROGIANO-Z

ceiling light; steel, white / plastic, white
Deckenleuchte; Stahl, weiss / Kunststoff, weiss
plafonnier; acier, blanc / plastique, blanc

↕ L 595, B 595, H 50

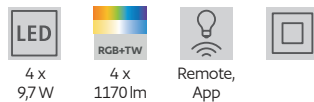

4 x 9,7 W
4 x 1170 lm
Remote, App

900482 PADROGIANO-Z

ceiling light; steel, white / plastic, white
Deckenleuchte; Stahl, weiss / Kunststoff, weiss
plafonnier; acier, blanc / plastique, blanc

↕ L 1200, B 300, H 50

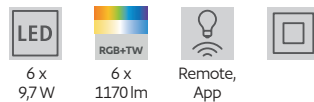

6 x 9,7 W
6 x 1170 lm
Remote, App



9008606244201



9008606244195



9008606244171



900486

900487

PADROGIANO-Z

The frame of these luminaires can switch between RGB colour tones, while the inner part can reproduce different shades of white between 2700K and 6500K. Customised lighting effects can be set using an app or remote control. Both the frame and the inner part can be switched on and off and dimmed separately.

Der Rahmen dieser Leuchten kann zwischen den RGB Farbtönen wechseln, der Innenteil kann verschiedene Weißtöne zwischen 2700K und 6500K wiedergeben. Durch Steuerung per App oder Fernbedienung können so individuelle Lichtspiele eingestellt werden. Sowohl der Rahmen als auch der Innenteil können separat ein- und ausgeschaltet sowie gedimmt werden.

Le cadre de ces luminaires peut changer de teinte RGB, la partie intérieure peut reproduire différentes nuances de blanc entre 2700K et 6500K. Il est ainsi possible de régler des jeux de lumière individuels en les commandant via une application ou une télécommande. Le cadre et la partie intérieure peuvent tous deux être allumés et éteints séparément et leur intensité peut être réglée.



900486 PADROGIANO-Z

ceiling light; steel, white / plastic, white
Deckenleuchte; Stahl, weiss / Kunststoff, weiss
plafonnier; acier, blanc / plastique, blanc

H 50, Ø 450



3 x
9,7 W



3 x
1170 lm



Remote,
App



900487 PADROGIANO-Z

ceiling light; steel, white / plastic, white
Deckenleuchte; Stahl, weiss / Kunststoff, weiss
plafonnier; acier, blanc / plastique, blanc

H 50, Ø 595



4 x
9,7 W



4 x
1170 lm



Remote,
App



9008606244218



9008606244225



99639



99548



99549

99639 HERRORA-Z

ceiling light; aluminium, white / plastic, white
Deckenleuchte; Alu, weiss / Kunststoff, weiss
plafonnier; aluminium, blanc / plastique, blanc

↕ L 450, B 450, H 40



99548 HERRORA-Z

ceiling light; aluminium, white / plastic, white
Deckenleuchte; Alu, weiss / Kunststoff, weiss
plafonnier; aluminium, blanc / plastique, blanc

↕ L 595, B 595, H 40

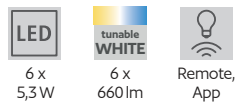

99549 HERRORA-Z

ceiling light; aluminium, white / plastic, white
Deckenleuchte; Alu, weiss / Kunststoff, weiss
plafonnier; aluminium, blanc / plastique, blanc

↕ L 1200, B 300, H 40

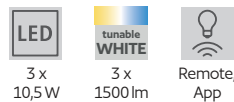

9002759996390



9002759995485



9002759995492

TURCONA-Z

The TURCONA-Z lighting series impresses with its frameless design and purist form language, which gives it a floating appearance. This allows it to blend harmoniously into any environment while combining timeless design with functional light. As a smart lighting solution, it also offers versatile lighting options – from warm white and neutral white to cool white light, as well as a wide selection of RGB colours.

Die Leuchtenserie TURCONA-Z überzeugt mit ihrem rahmenlosen Design und einer puristischen Formensprache, die ihr eine schwebende Anmutung verleiht. Dadurch fügt sie sich harmonisch in jede Umgebung ein und vereint zeitloses Design mit funktionalem Licht. Als smarte Lichtlösung eröffnet sie vielseitige Beleuchtungsmöglichkeiten – von warmweißem über neutralweißes bis hin zu kaltweißem Licht sowie einer großen Auswahl an RGB-Farben.

La série de luminaires TURCONA-Z séduit par son design sans cadre et son langage formel épuré, qui lui confèrent une apparence flottante. Elle s'intègre ainsi harmonieusement dans tous les environnements tout en associant un design intemporel à un éclairage fonctionnel. En tant que solution d'éclairage intelligente, elle offre également de multiples possibilités d'éclairage – de la lumière blanc chaud, blanc neutre à blanc froid, ainsi qu'un large choix de couleurs RGB.

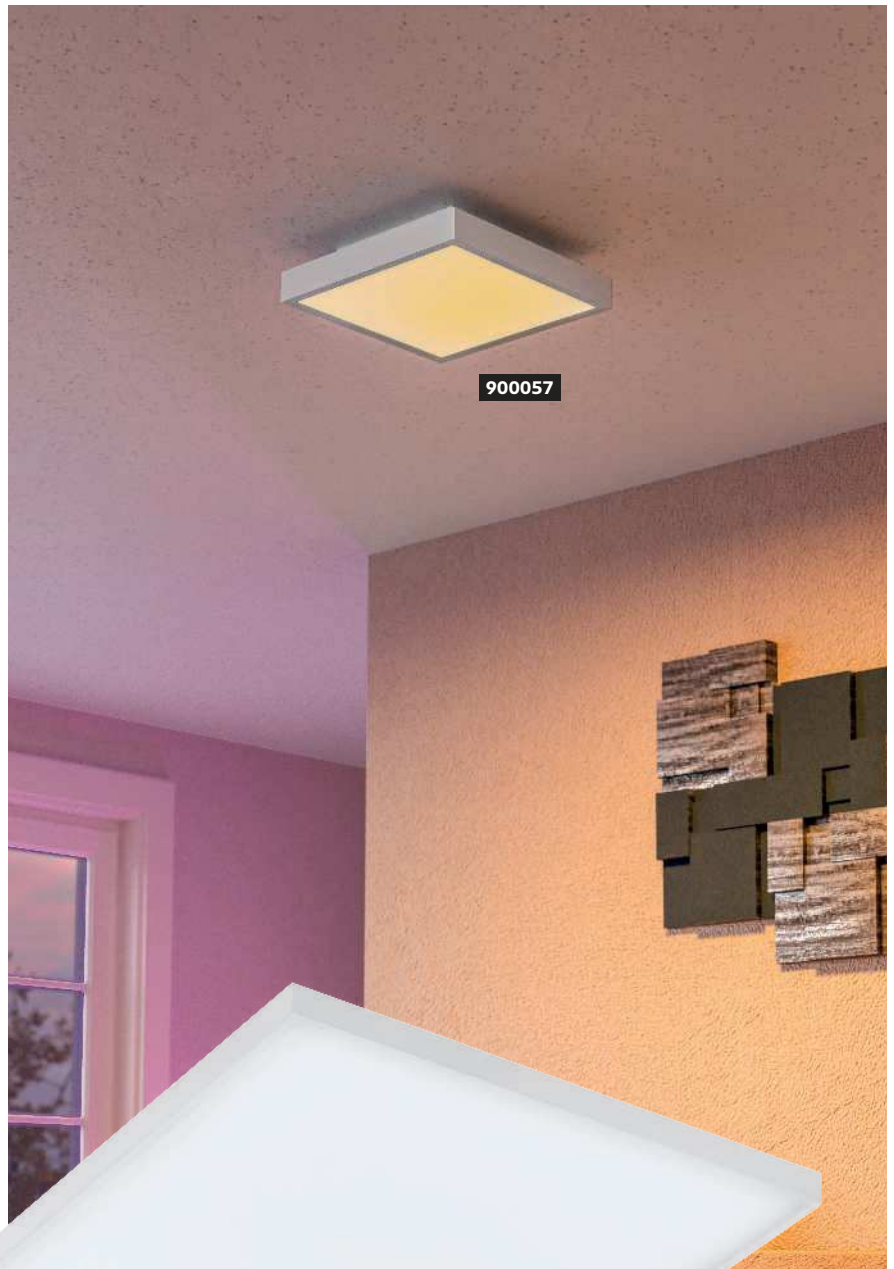

900058 TURCONA-Z

ceiling light; steel, aluminium, white / plastic, white

Deckenleuchte; Stahl, Alu, weiss / Kunststoff, weiss

plafonnier; acier, aluminium, blanc / plastique, blanc

↳ L 450, B 450, H 70



6 x
3,8 W



6 x
400 lm



Remote,
App



9008606221943

900059 TURCONA-Z

ceiling light; steel, aluminium, white / plastic, white

Deckenleuchte; Stahl, Alu, weiss / Kunststoff, weiss

plafonnier; acier, aluminium, blanc / plastique, blanc

↳ L 600, B 600, H 75



6 x
5,4 W



6 x
666 lm



Remote,
App



9008606221950

900057 TURCONA-Z

ceiling light; steel, aluminium, white / plastic, white

Deckenleuchte; Stahl, Alu, weiss / Kunststoff, weiss

plafonnier; acier, aluminium, blanc / plastique, blanc

↳ L 300, B 300, H 50



1 x
16 W



1 x
1750 lm



Remote,
App



9008606221936



900061



900062

900061 TURCONA-Z

ceiling light; steel, aluminium, white / plastic, white

Deckenleuchte; Stahl, Alu, weiss / Kunststoff, weiss

plafonnier; acier, aluminium, blanc / plastique, blanc

↕ L 1200, B 300, H 75



3 x
10,6W



3 x
1333lm



Remote,
App



900062 TURCONA-Z

ceiling light; steel, aluminium, white / plastic, white

Deckenleuchte; Stahl, Alu, weiss / Kunststoff, weiss

plafonnier; acier, aluminium, blanc / plastique, blanc

↕ L 1200, B 100, H 75



1 x
34,2W



1 x
3910lm



Remote,
App



9008606221967



9008606221974

MORADILLO-Z

The fully RGB-capable panel enables flexible lighting design, allowing the illumination to be adjusted at any time to match the desired mood.

Das voll RGB-fähige Panel ermöglicht eine flexible Lichtgestaltung, sodass sich die Beleuchtung jederzeit an die gewünschte Stimmung anpassen lässt.

Le panneau entièrement compatible RGB permet une conception lumineuse flexible, de sorte que l'éclairage puisse être adapté à tout moment à l'ambiance souhaitée.

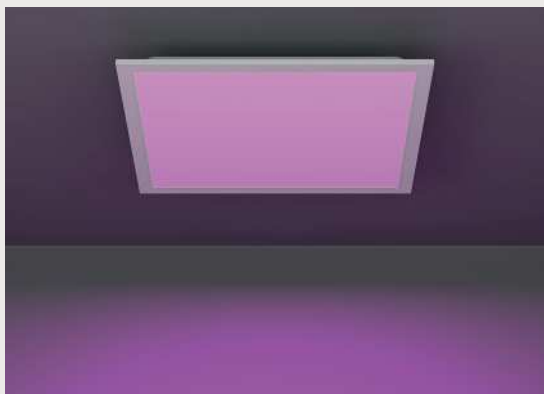

901517

901516

901517 MORADILLO-Z

ceiling light; steel, white / plastic, white
Deckenleuchte; Stahl, weiss / Kunststoff, weiss
plafonnier; acier, blanc / plastique, blanc

↻ L 1195, B 145, H 61



1 x
28 W



1 x
3300 lm



Remote,
App



901516 MORADILLO-Z

ceiling light; steel, white / plastic, white
Deckenleuchte; Stahl, weiss / Kunststoff, weiss
plafonnier; acier, blanc / plastique, blanc

↻ L 1195, B 295, H 61



1 x
34 W



1 x
4400 lm



Remote,
App



9008606342204



9008606342198



901512

901513

901514

901512 MORADILLO-Z

ceiling light; steel, white / plastic, white
Deckenleuchte; Stahl, weiss / Kunststoff, weiss
plafonnier; acier, blanc / plastique, blanc

↕ L 295, B 295, H 61



1 x 14 W
1 x 1700 lm
Remote, App

901513 MORADILLO-Z

ceiling light; steel, white / plastic, white
Deckenleuchte; Stahl, weiss / Kunststoff, weiss
plafonnier; acier, blanc / plastique, blanc

↕ L 393, B 393, H 61



1 x 19 W
1 x 2300 lm
Remote, App

901514 MORADILLO-Z

ceiling light; steel, white / plastic, white
Deckenleuchte; Stahl, weiss / Kunststoff, weiss
plafonnier; acier, blanc / plastique, blanc

↕ L 595, B 595, H 61



1 x 33 W
1 x 4400 lm
Remote, App



9008606342167



9008606342174



9008606342181



901505







901506

901505 MORADILLO-Z

ceiling light; steel, black / plastic, white
 Deckenleuchte; Stahl, schwarz / Kunststoff, weiss
 plafonnier; acier, noir / plastique, blanc





 L 295, B 295, H 61

			
1 x 14 W	1 x 1700 lm	Remote, App	

901506 MORADILLO-Z

ceiling light; steel, black / plastic, white
 Deckenleuchte; Stahl, schwarz / Kunststoff, weiss
 plafonnier; acier, noir / plastique, blanc

 L 393, B 393, H 61

			
1 x 19 W	1 x 2300 lm	Remote, App	



9008606342105



9008606342112

MORADILLO-Z
DETAIL

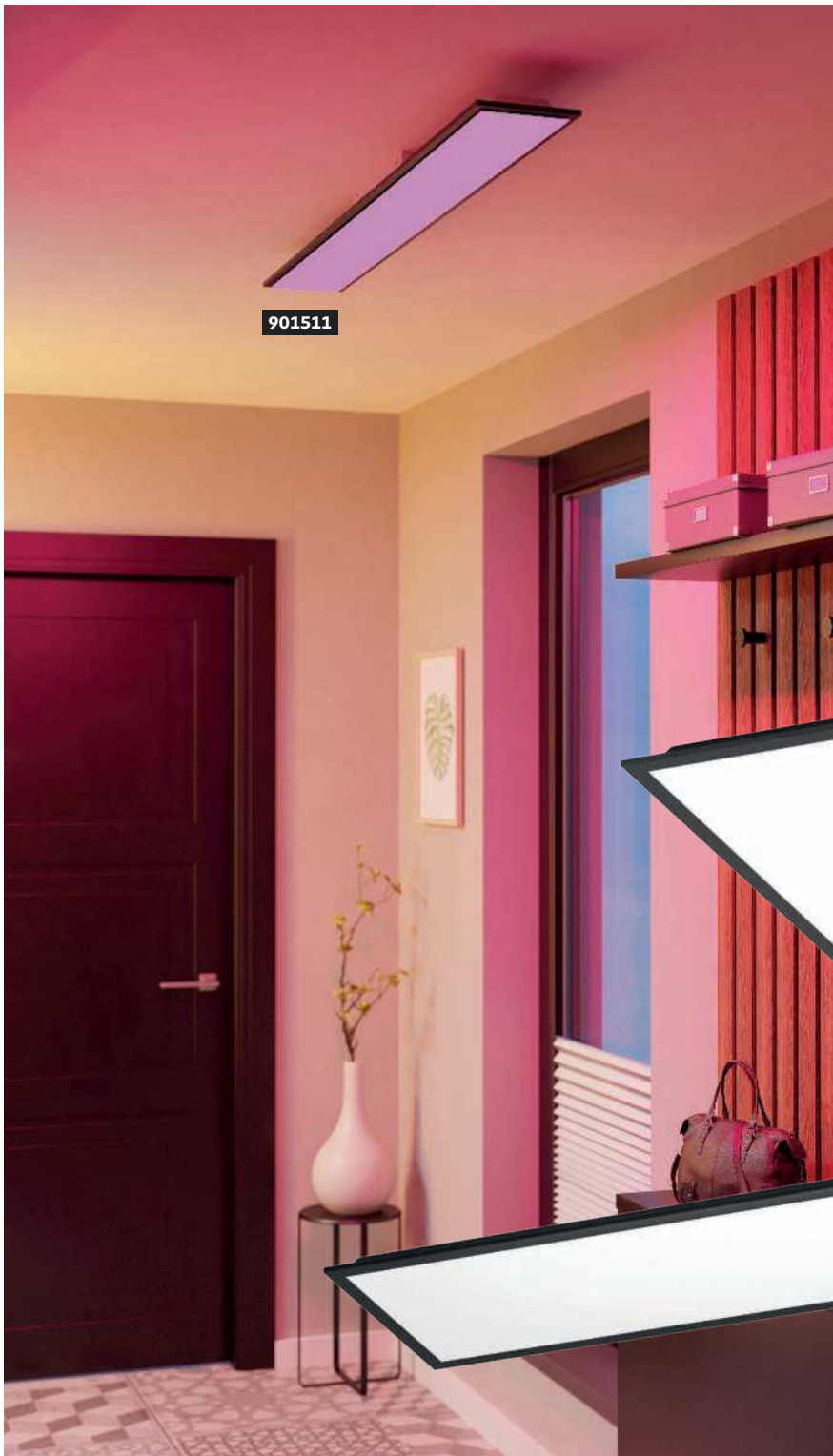

901511



901507



901509

901511 MORADILLO-Z

ceiling light; steel, black / plastic, white
Deckenleuchte; Stahl, schwarz / Kunststoff, weiss
plafonnier; acier, noir / plastique, blanc

↕ L 1195, B 145, H 61



1 x 28 W
1 x 3300 lm
Remote, App

901507 MORADILLO-Z

ceiling light; steel, black / plastic, white
Deckenleuchte; Stahl, schwarz / Kunststoff, weiss
plafonnier; acier, noir / plastique, blanc

↕ L 595, B 595, H 61



1 x 33 W
1 x 4400 lm
Remote, App

901509 MORADILLO-Z

ceiling light; steel, black / plastic, white
Deckenleuchte; Stahl, schwarz / Kunststoff, weiss
plafonnier; acier, noir / plastique, blanc

↕ L 1195, B 295, H 61



1 x 34 W
1 x 4400 lm
Remote, App



9008606342143



9008606342129



9008606342136

SALOBRENA-Z

These rectangular ceiling panels impress with their flat design and provide uniform, bright lighting. Thanks to CCT technology, the light can be infinitely adjusted between warm white and cool white, ideal for different applications. The luminaires are smart, can be controlled via app, remote control or smart home system and offer the flexibility to adjust the luminaires as required. Perfect for modern living spaces, offices or kitchens where both brightness and style are required.

Dieses rechteckigen Deckenpaneel überzeugen mit flachem Design und sorgen für eine gleichmäßige, helle Beleuchtung. Dank CCT-Technologie lässt sich das Licht stufenlos zwischen Warmweiß und Kaltweiß einstellen, ideal für unterschiedliche Anwendungen. Die Leuchten sind smart, lassen sich per App, Fernbedienung oder Smart Home System steuern und bieten die Flexibilität, das Licht nach Bedarf anzupassen. Perfekt für moderne Wohnräume, Büros oder Küchen, in denen sowohl Helligkeit als auch Stil gefragt sind.

Ces panneaux de plafond rectangulaires séduisent par leur design plat et assurent un éclairage uniforme et lumineux. Grâce à la technologie CCT, la lumière peut être réglée en continu entre le blanc chaud et le blanc froid, idéal pour différentes applications. Les luminaires sont intelligents, peuvent être contrôlés via une application, une télécommande ou un système Smart Home et offrent la flexibilité d'adapter la lumière selon les besoins. Parfait pour les pièces d'habitation, les bureaux ou les cuisines modernes où l'on recherche à la fois la luminosité et le style.



900044



900045



900046

900044 SALOBRENA-Z

ceiling light; aluminium, white / plastic, white
Deckenleuchte; Alu, weiss / Kunststoff, weiss
plafonnier; aluminium, blanc / plastique, blanc

↕ L 300, B 300, H 50



1 x
15,3 W



1 x
1790 lm



Remote,
App



900045 SALOBRENA-Z

ceiling light; aluminium, white / plastic, white
Deckenleuchte; Alu, weiss / Kunststoff, weiss
plafonnier; aluminium, blanc / plastique, blanc

↕ L 450, B 450, H 50



1 x
21,5 W



1 x
2500 lm



Remote,
App



900046 SALOBRENA-Z

ceiling light; aluminium, white / plastic, white
Deckenleuchte; Alu, weiss / Kunststoff, weiss
plafonnier; aluminium, blanc / plastique, blanc

↕ L 595, B 595, H 50



1 x
33 W



1 x
4100 lm



Remote,
App



9008606221813



9008606221820



9008606221837



900048



900047

900048 SALOBRENA-Z

ceiling light; aluminium, white / plastic, white
Deckenleuchte; Alu, weiss / Kunststoff, weiss
plafonnier; aluminium, blanc / plastique,
blanc

↕ L 1200, B 100, H 45



1 x
33,5W



1 x
4150 lm



Remote,
App



900047 SALOBRENA-Z

ceiling light; aluminium, white / plastic, white
Deckenleuchte; Alu, weiss / Kunststoff, weiss
plafonnier; aluminium, blanc / plastique,
blanc

↕ L 1200, B 300, H 50



1 x
33,5W



1 x
4150 lm



Remote,
App



INCL. / INKL. / INCLUS

Included in the scope of delivery for
the following items:

Bei folgenden Artikeln im
Lieferumfang enthalten:

Les éléments suivants sont inclus
dans la livraison :

900044, 900045, 900046, 900047,
900048



9008606221851



9008606221844



900049



900051



900052

900049 SALOBRENA-Z

ceiling light; aluminium, black / plastic, white
 Deckenleuchte; Alu, schwarz / Kunststoff, weiss
 plafonnier; aluminium, noir / plastique, blanc

↕ L 300, B 300, H 50

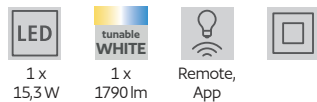

900051 SALOBRENA-Z

ceiling light; aluminium, black / plastic, white
 Deckenleuchte; Alu, schwarz / Kunststoff, weiss
 plafonnier; aluminium, noir / plastique, blanc

↕ L 450, B 450, H 50

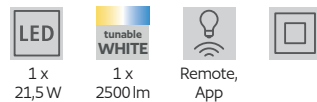

900052 SALOBRENA-Z

ceiling light; aluminium, black / plastic, white
 Deckenleuchte; Alu, schwarz / Kunststoff, weiss
 plafonnier; aluminium, noir / plastique, blanc

↕ L 595, B 595, H 50

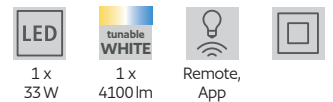

9008606221868



9008606221875



9008606221882



900053



900095

900053 SALOBRENA-Z

ceiling light; aluminium, black / plastic, white
Deckenleuchte; Alu, schwarz / Kunststoff, weiss
plafonnier; aluminium, noir / plastique, blanc

↕ L 1200, B 300, H 50



1 x
33,5W



1 x
4150 lm



Remote,
App



900095 SALOBRENA-Z

ceiling light; aluminium, steel, black / plastic, white
Deckenleuchte; Alu, Stahl, schwarz / Kunststoff, weiss
plafonnier; aluminium, acier, noir / plastique, blanc

↕ L 1200, B 100, H 45



1 x
33,5W



1 x
4150 lm



Remote,
App



INCL. / INKL. / INCLUS

Included in the scope of delivery for the following items:

Bei folgenden Artikeln im Lieferumfang enthalten:

Les éléments suivants sont inclus dans la livraison :

900049, 900051, 900052, 900053, 900095



9008606221899



9008606225552

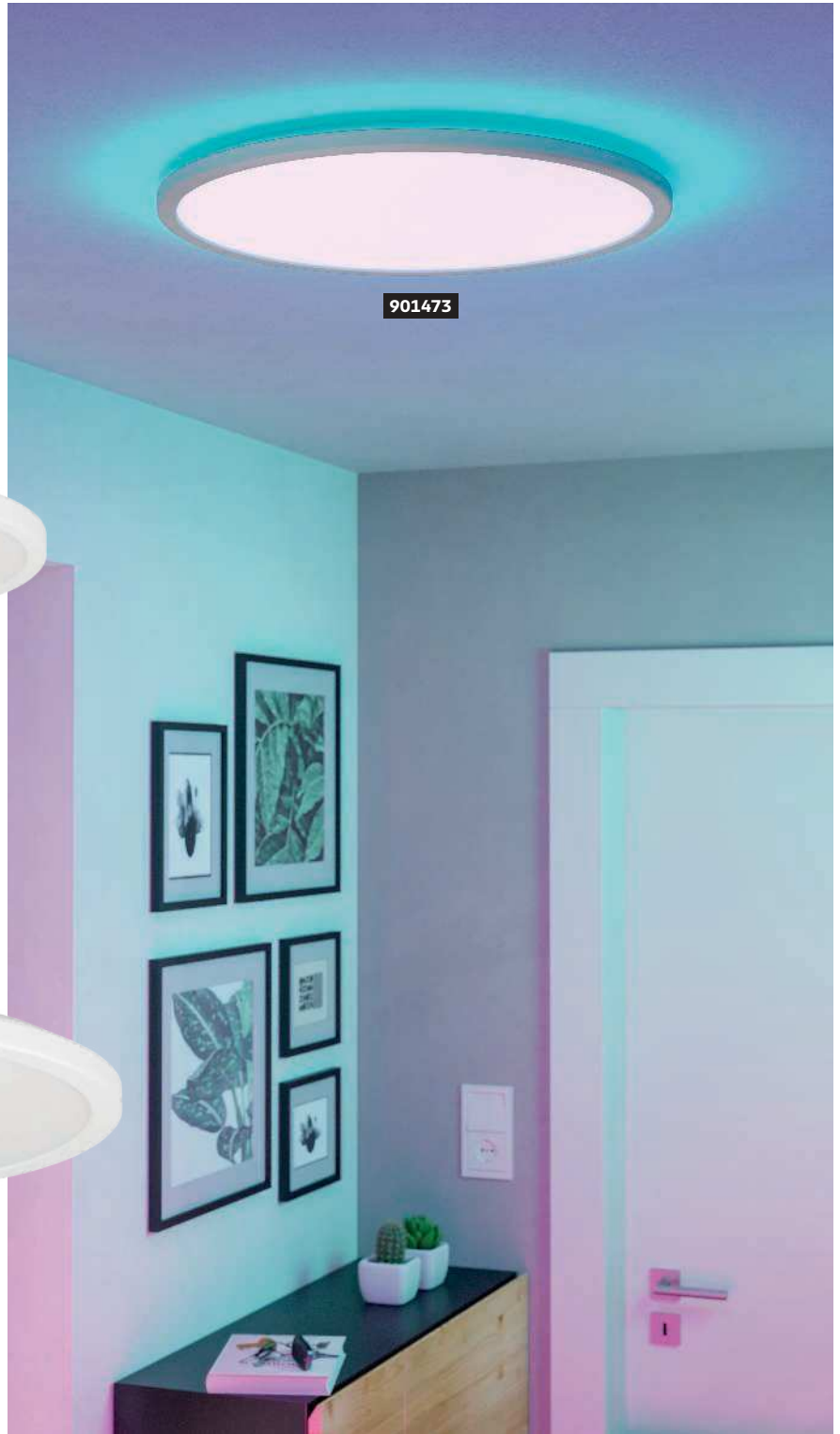

901471



901472



901471 ROVITO-Z
ceiling light; plastic, white / plastic, white
Deckenleuchte; Kunststoff, weiss / Kunststoff, weiss
plafonnier; plastique, blanc / plastique, blanc

H 30, Ø 300

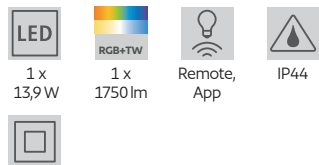

9008606329779

901472 ROVITO-Z
ceiling light; plastic, white / plastic, white
Deckenleuchte; Kunststoff, weiss / Kunststoff, weiss
plafonnier; plastique, blanc / plastique, blanc

H 30, Ø 389

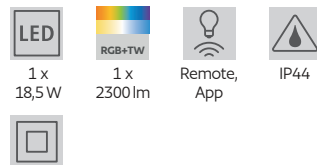

9008606329786

901473 ROVITO-Z
ceiling light; plastic, white / plastic, white
Deckenleuchte; Kunststoff, weiss / Kunststoff, weiss
plafonnier; plastique, blanc / plastique, blanc

H 32, Ø 500

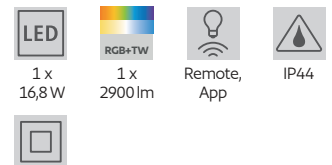

9008606329793

ROVITO-Z

The upper light of these luminaires offers individual RGB settings for indirect illumination, while the lower light can be adjusted from warm white to cool white. Both the direct and indirect light can be turned on and off separately and dimmed.

Das obere Licht dieser Leuchten bietet individuelle RGB-Einstellungen für eine indirekte Beleuchtung, während das untere Licht von warmweiß bis kaltweiß eingestellt werden kann. Sowohl das direkte als auch das indirekte Licht können separat ein- und ausgeschaltet sowie gedimmt werden.

La lumière supérieure de ce luminaire offre des réglages RVB individuels pour l'éclairage indirect, tandis que la lumière inférieure peut être réglée du blanc chaud au blanc froid. La lumière directe et indirecte peuvent être allumée, éteinte et atténuée séparément.



901463



901465



901464



901463 ROVITO-Z

ceiling light; plastic, black / plastic, white
Deckenleuchte; Kunststoff, schwarz / Kunststoff, weiss
plafonnier; plastique, noir / plastique, blanc

H 30, Ø 300

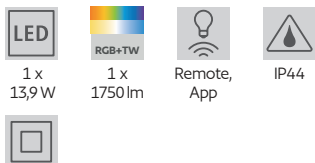

901464 ROVITO-Z

ceiling light; plastic, black / plastic, white
Deckenleuchte; Kunststoff, schwarz / Kunststoff, weiss
plafonnier; plastique, noir / plastique, blanc

H 30, Ø 389

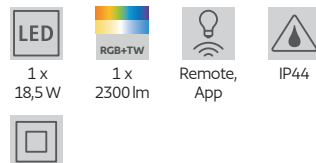

901465 ROVITO-Z

ceiling light; plastic, black / plastic, white
Deckenleuchte; Kunststoff, schwarz / Kunststoff, weiss
plafonnier; plastique, noir / plastique, blanc

H 32, Ø 500

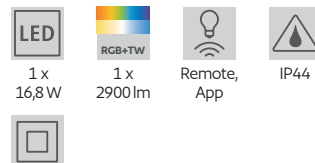



901474 ROVITO-Z

ceiling light; plastic, white / plastic, white
Deckenleuchte; Kunststoff, weiss / Kunststoff, weiss
plafonnier; plastique, blanc / plastique, blanc

L 290, B 290, H 30

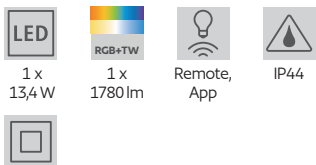

9008606329809

901475 ROVITO-Z

ceiling light; plastic, white / plastic, white
Deckenleuchte; Kunststoff, weiss / Kunststoff, weiss
plafonnier; plastique, blanc / plastique, blanc

L 390, B 390, H 30

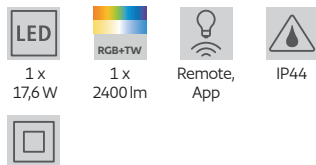

9008606329816

901476 ROVITO-Z

ceiling light; plastic, white / plastic, white
Deckenleuchte; Kunststoff, weiss / Kunststoff, weiss
plafonnier; plastique, blanc / plastique, blanc

L 500, B 500, H 32

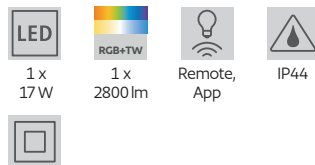

9008606329823

901477 ROVITO-Z

ceiling light; plastic, white / plastic, white
Deckenleuchte; Kunststoff, weiss / Kunststoff, weiss
plafonnier; plastique, blanc / plastique, blanc

L 570, B 300, H 30

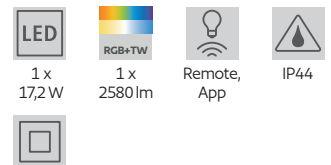

9008606329830



901466



901467

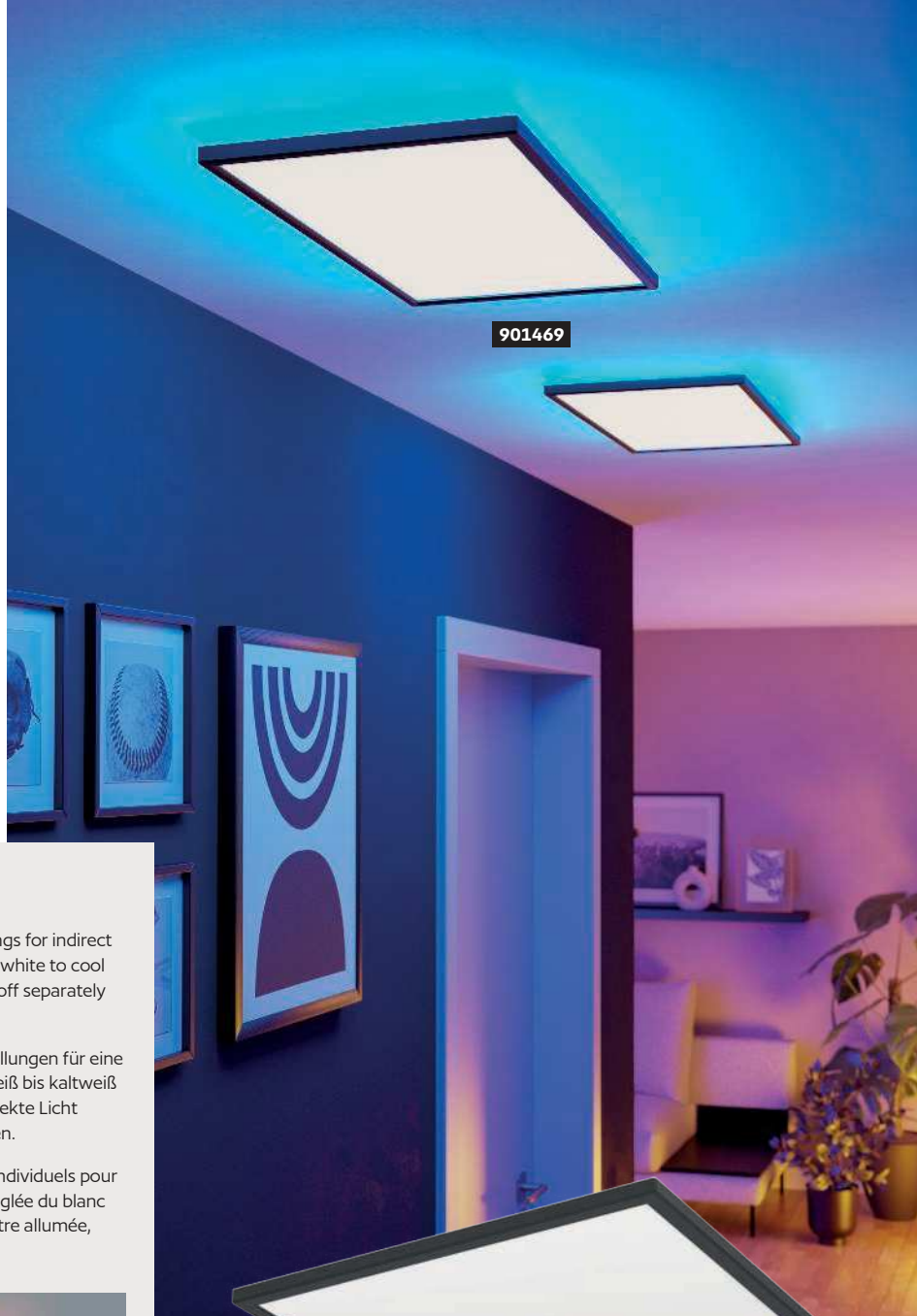

901469

901468

ROVITO-Z

The upper light of these luminaires offers individual RGB settings for indirect illumination, while the lower light can be adjusted from warm white to cool white. Both the direct and indirect light can be turned on and off separately and dimmed.

Das obere Licht dieser Leuchten bietet individuelle RGB-Einstellungen für eine indirekte Beleuchtung, während das untere Licht von warmweiß bis kaltweiß eingestellt werden kann. Sowohl das direkte als auch das indirekte Licht können separat ein- und ausgeschaltet sowie gedimmt werden.

La lumière supérieure de ce luminaire offre des réglages RVB individuels pour l'éclairage indirect, tandis que la lumière inférieure peut être réglée du blanc chaud au blanc froid. La lumière directe et indirecte peuvent être allumée, éteinte et atténuée séparément.



901466 ROVITO-Z

ceiling light; plastic, black / plastic, white
Deckenleuchte; Kunststoff, schwarz / Kunststoff, weiss
plafonnier; plastique, noir / plastique, blanc

↕ L 290, B 290, H 30



1 x
13,4 W



1 x
1780 lm



Remote,
App



IP44



901467 ROVITO-Z

ceiling light; plastic, black / plastic, white
Deckenleuchte; Kunststoff, schwarz / Kunststoff, weiss
plafonnier; plastique, noir / plastique, blanc

↕ L 390, B 390, H 30



1 x
17,6 W



1 x
2400 lm



Remote,
App



IP44



901469 ROVITO-Z

ceiling light; plastic, black / plastic, white
Deckenleuchte; Kunststoff, schwarz / Kunststoff, weiss
plafonnier; plastique, noir / plastique, blanc

↕ L 570, B 300, H 30



1 x
17,2 W



1 x
2580 lm



Remote,
App



IP44



901468 ROVITO-Z

ceiling light; plastic, black / plastic, white
Deckenleuchte; Kunststoff, schwarz / Kunststoff, weiss
plafonnier; plastique, noir / plastique, blanc

↕ L 500, B 500, H 32



1 x
17 W



1 x
2800 lm



Remote,
App



IP44



9008606329731



9008606329748



9008606329762



9008606329755



901108

901109



INCL. / INKL. / INCLUS

Fastening clips are included in the scope of delivery for the following items:

Bevestigingsclips sind bei folgenden Artikeln im Lieferumfang enthalten:

Les clips de fixation sont inclus dans la livraison des articles suivants :

901108, 901109



901108 NEON-STRIPE-Z

bar/strip light; plastic, white
Leuchtband/-stab; Kunststoff, weiss
bande lumineuse / bâton l; plastique, blanc

901109 NEON-STRIPE-Z

bar/strip light; plastic, white
Leuchtband/-stab; Kunststoff, weiss
bande lumineuse / bâton l; plastique, blanc

⚡ L 3000, B 18, H 8



1 x
20 W



1 x
2400 lm



Remote,
App



⚡ L 5000, B 18, H 8



1 x
30 W



1 x
3400 lm



Remote,
App



NEON-STRIPE-Z

These Stripes cannot be shortened!

Diese Stripes sind nicht kürzbar!

Ces bandes ne peuvent pas être raccourcies !



9008606295265



9008606295272

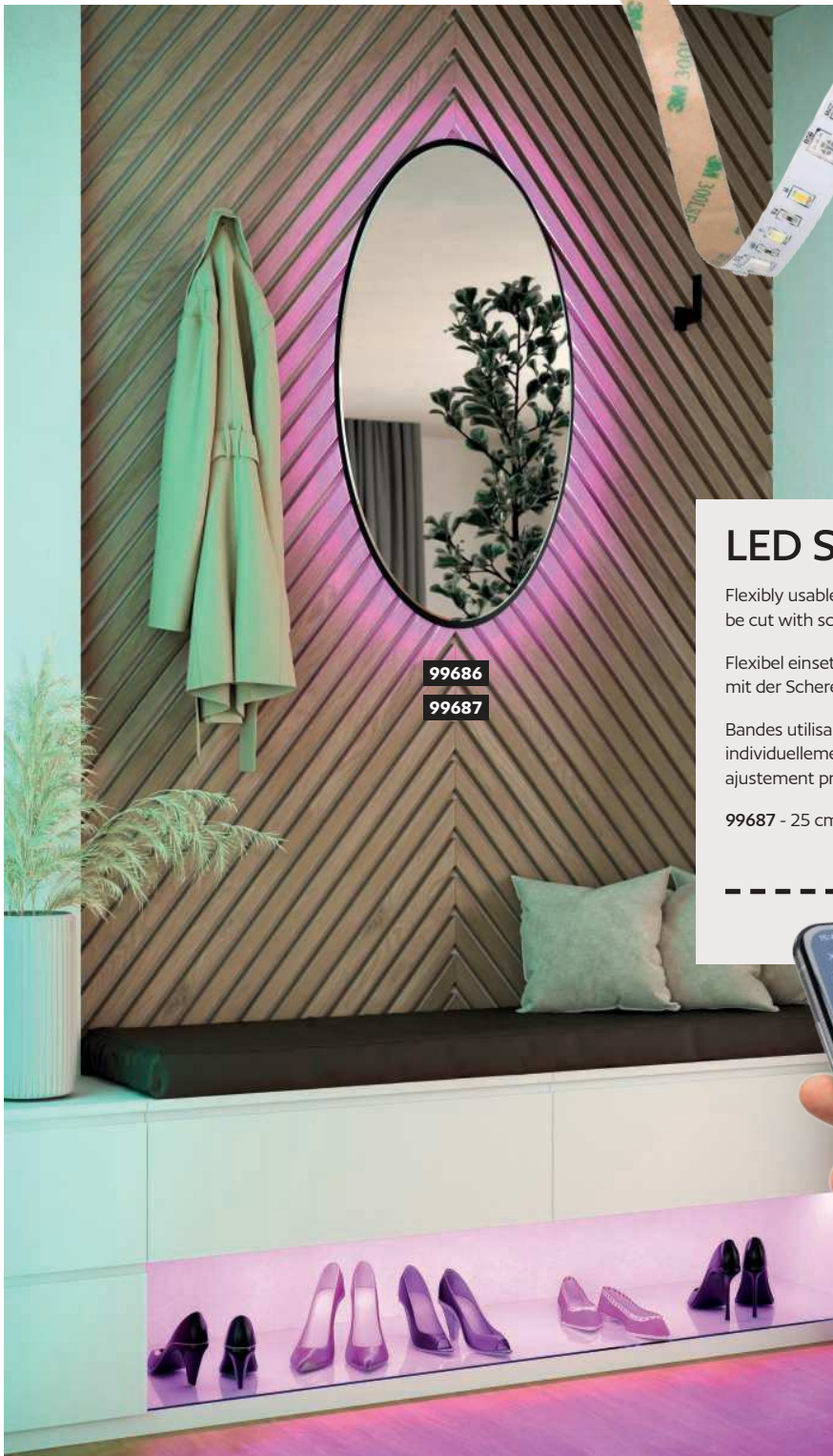

99686
99687

LED STRIPE-Z
DETAIL

LED STRIPE-Z

Flexibly usable strips – individually adaptable and can be cut with scissors for a precise fit.

Flexibel einsetzbare Stripes – individuell anpassbar und mit der Schere kürzbar für eine passgenaue Lösung.

Bandes utilisables de manière flexible – adaptables individuellement et découpables aux ciseaux pour un ajustement précis.

99687 - 25 cm



99686 LED STRIPE-Z

bar/strip light; plastic, white
Leuchtband/-stab; Kunststoff, weiss
bande lumineuse / bâton l; plastique, blanc

↕ L 5000, B 12, H 2



1 x 11 W
1 x 1250 lm

99687 LED STRIPE-Z

bar/strip light; plastic, white
Leuchtband/-stab; Kunststoff, weiss
bande lumineuse / bâton l; plastique, blanc

↕ L 8000, B 12, H 2



8 x 3 W
8 x 330 lm

INCL. / INKL. / INCLUS

Driver included in the scope of delivery for the following items:

Treiber bei folgenden Artikeln im Lieferumfang enthalten:

Pilote inclus dans la livraison pour les articles suivants :

901108, 901109, 99687



9002759996864



9002759996871

TRACK SYSTEM

SCHIENENSYSTEM
SYSTÈMES DE RAIL



Collection
Produktwelt
Univers produit



EN

MODERN TRACK SYSTEMS FOR INDIVIDUAL ROOM SOLUTIONS

- EASY TRACK - Designed to enhance any space's ambiance and functionality, this high voltage track system offers an accessible and practical solution for your home. A simple offer, unlimited possibilities, attractive price and accessories fully integrated into the metal track.
- TRACK PLUS - This extra-flat track takes the track system to another level. Perfect for wall and ceiling mounting, this track can be integrated anywhere. Set the CCT and brightness level of your accessories as you like with the included remote control and manage your products in 2 different groups for greater flexibility.

DE

MODERNE SCHIENENSYSTEME FÜR INDIVIDUELLE RAUMLÖSUNGEN

- EASY TRACK - Entwickelt, um das Ambiente und die Funktionalität eines jeden Raumes zu verbessern, bietet dieses Hochspannungsschienensystem eine zugängliche und praktische Lösung für Ihr Zuhause. Ein einfaches Angebot, unbegrenzte Möglichkeiten, ein attraktiver Preis und vollständig in die Metallschiene integriertes Zubehör.
- TRACK PLUS - Diese extraflache Schiene hebt das Schienensystem auf eine neue Ebene. Perfekt für die Wand- und Deckenmontage, kann diese Schiene überall integriert werden. Mit der mitgelieferten Fernbedienung können Sie die Farbtemperatur und die Helligkeit Ihres Zubehörs nach Belieben einstellen und Ihre Produkte in 2 verschiedenen Gruppen verwalten, um mehr Flexibilität zu erreichen.

FR

SYSTÈMES DE RAILS MODERNES POUR DES SOLUTIONS D'AMÉNAGEMENT PERSONNALISÉES

- EASY TRACK - Conçu pour améliorer l'ambiance et la fonctionnalité de tout espace, ce système de rail haute tension offre une solution accessible et pratique pour votre maison. Une offre simple, des possibilités illimitées, un prix attractif et des accessoires entièrement intégrés dans le rail métallique.
- TRACK PLUS - Ce rail extra-plat fait passer le système de rail à un autre niveau. Parfait pour un montage mural ou au plafond, ce rail peut être intégré partout. Réglez le CCT et le niveau de luminosité de vos accessoires comme vous le souhaitez à l'aide de la télécommande fournie et gérez vos produits dans 2 groupes différents pour une plus grande flexibilité.

TRACK SYSTEM

EASY TRACK

SCHIENENSYSTEM EASY TRACK
SYSTÈMES DE RAIL EASY TRACK

Advantages

- Easy ceiling and pendant mounting
- Flexible usage with GU10
- Seamless Design
- Entry-level price
- Simplified offer, easy to understand for end consumer
- Easy Installation
- Quick Assembly and Disassembly of Accessories for easy maintenance and customization

Vorteile

- Einfache Decken- und Pendelmontage
- Flexibler Einsatz mit GU10
- Nahtloses Design
- Einstiegspreis
- Vereinfachtes, für den Endverbraucher leicht verständliches Angebot
- Einfache Installation
- Schnelle Montage und Demontage des Zubehörs für einfache Wartung und Anpassung

Avantages

- Montage facile au plafond et en suspension
- Utilisation flexible avec GU10
- Design homogène
- Prix d'entrée de gamme
- Offre simplifiée, facile à comprendre pour le consommateur final
- Installation facile
- Montage et démontage rapides des accessoires pour une maintenance et une personnalisation aisées

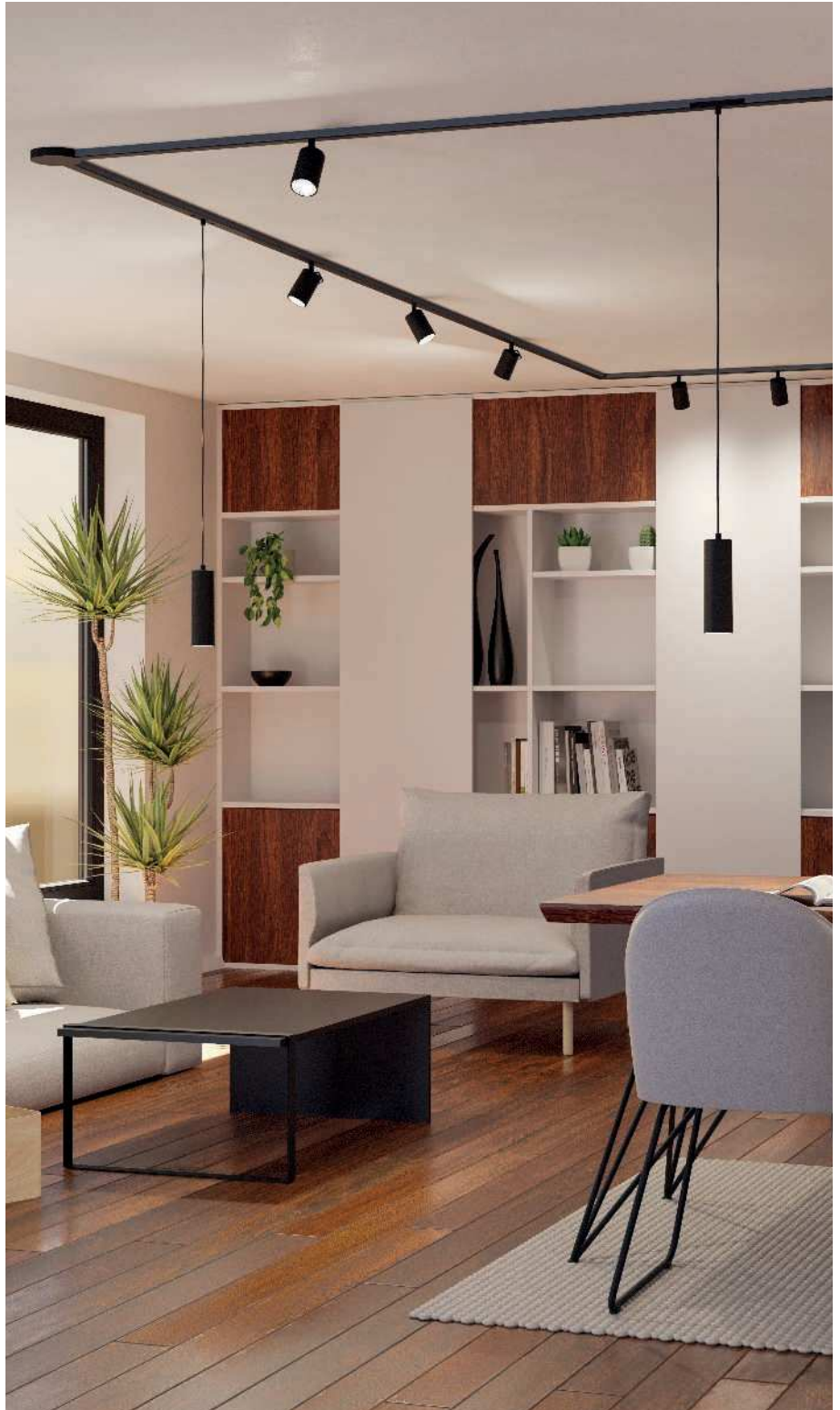

More Information on our website.
Mehr Informationen auf unserer Website.
Plus d'infos sur notre site web.

SEAMLESS INTEGRATION
NAHTLOSE INTEGRATION
INTÉGRATION TRANSPARENTE

Experience seamless design with integrated track spots.

Erleben Sie nahtloses Design mit in die Schiene integrierten Spots.

Découvrez une conception sans faille avec des spots de piste intégrés.



1 2 3 4

Customize your lighting experience by fitting your preferred GU10 bulb into our versatile models. With three light sources to choose from, you can create the perfect ambiance for your home. Rotate the spots to adjust the direction of light as desired. Use the E27 Adapter to extend your track with your preferred shade.

Passen Sie Ihr Lichtelebnis an, indem Sie Ihre bevorzugte GU10-Lampe in unsere vielseitigen Modelle einsetzen. Mit den drei zur Auswahl stehenden Lichtquellen können Sie das perfekte Ambiente für Ihr Zuhause schaffen. Drehen Sie die Spots, um die Lichtrichtung nach Wunsch einzustellen. Verwenden Sie den E27-Adapter, um Ihre Schiene mit Ihrem bevorzugten Lampenschirm zu erweitern.

Personnalisez votre expérience d'éclairage en installant l'ampoule GU10 de votre choix dans nos modèles polyvalents. Avec trois sources de lumière au choix, vous pouvez créer l'ambiance parfaite pour votre maison. Faites pivoter les spots pour ajuster la direction de la lumière comme vous le souhaitez. Utilisez l'adaptateur E27 pour prolonger votre rail avec l'abat-jour de votre choix.



FEW CONNECTORS, INFINITE POSSIBILITIES

WENIGE STECKVERBINDER, UNENDLICHE MÖGLICHKEITEN
PEU DE CONNECTEURS, DES POSSIBILITÉS INFINIES

The rail can be cut to any length, allowing you to tailor the rail system to your specific project.

Die Schiene kann an jeder beliebigen Stelle gekürzt werden, so können Sie das Schienensystem individuell an Ihr Projekt anpassen.

Le rail peut être raccourci à n'importe quel endroit, ce qui vous permet d'adapter le système de rails à votre projet.

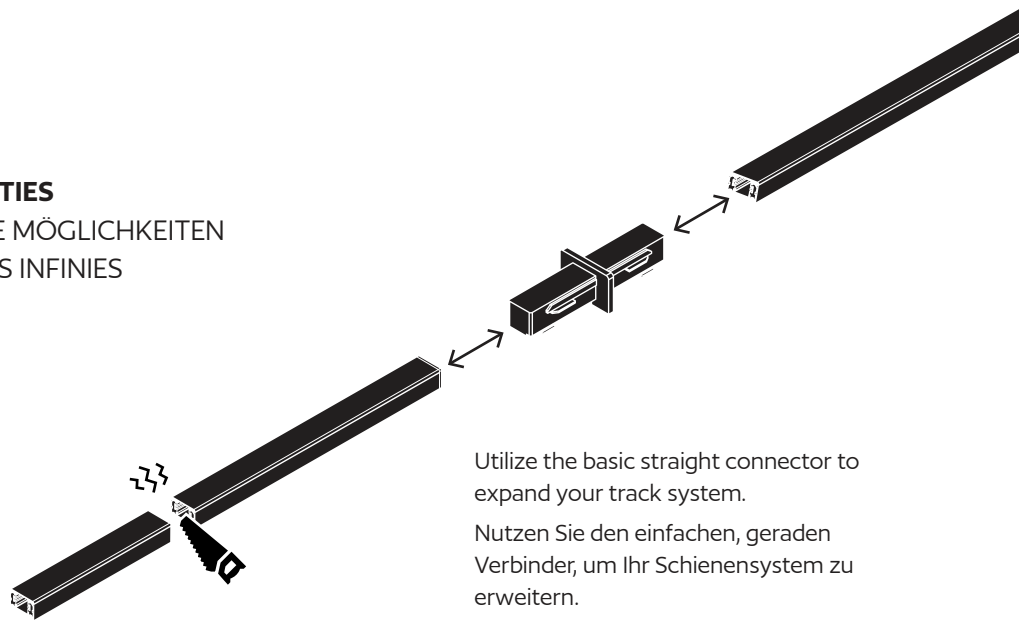

Utilize the basic straight connector to expand your track system.

Nutzen Sie den einfachen, geraden Verbinder, um Ihr Schienensystem zu erweitern.

Utilisez le connecteur droit de base pour étendre votre système de rails.

The corner connector not only creates an L-shaped connection but also accommodates angles ranging from 75 to 180 degrees.

Der Eckverbinder schafft nicht nur eine L-förmige Verbindung, sondern ermöglicht auch Winkel von 75 bis 180 Grad.

Le connecteur angulaire permet non seulement de créer une connexion en forme de L, mais aussi d'accommoder des angles allant de 75 à 180 degrés.



The versatile all-in-one feeder functions both as a centre or side feeder and as a connector to create L, T or X connections. The connectors marked in grey are always included with the rail.

Der vielseitige All-in-one Feeder fungiert sowohl als mittlerer oder seitlicher Einspeiser als auch als Verbinder, um L-, T- oder X-Verbindungen herzustellen. Die grau markierten Verbinder liegen immer der Schiene bei.

L'alimentateur polyvalent tout-en-un fonctionne aussi bien comme alimentateur central ou latéral que comme connecteur pour réaliser des connexions en L, en T ou en X. Les connecteurs marqués en gris sont toujours fournis avec le rail.



MODULAR SOLUTION
MODULARE LÖSUNG
SOLUTION MODULAIRE

With our innovative track system, which can be extended as required, you can place the power outlet inconspicuously exactly where it is needed. A cover is included for a seamless design.

Mit unserem innovativen, je nach Wunsch erweiterbaren Schienensystem bringen Sie den Stromauslass unauffällig genau dorthin, wo er gebraucht wird. Eine mitgelieferte Abdeckung sorgt für ein nahtloses Design.

Grâce à notre système de rails innovant et extensible à souhait, vous placez discrètement la sortie de courant exactement là où vous en avez besoin. Un couvercle fourni assure un design sans faille.





901653



901652

EASYT SET 4 SPOTS

Individually customizable.

Individuell anpassbar.

Personnalisable individuellement.



901653 EASYT SET 3 SPOTS

system; aluminium, plastic, black / plastic, black

System; Alu, Kunststoff, schwarz / Kunststoff, schwarz

système; aluminium, plastique, noir / plastique, noir

⚡ L 1020, B 55, H 140



GU10



3 x
10 W

901652 EASYT SET 4 SPOTS

system; aluminium, plastic, black / plastic, black

System; Alu, Kunststoff, schwarz / Kunststoff, schwarz

système; aluminium, plastique, noir / plastique, noir

⚡ L 1925, B 55, H 140



GU10



4 x
10 W



9008606323388



9008606323371



901639



901638

901639 EASYT FEEDER

accessory; plastic, black
Zubehör; Kunststoff, schwarz
Accessoires; plastique, noir

↕ H 20, Ø 120

901638 EASYT TRACK

accessory; aluminium, black
Zubehör; Alu, schwarz
Accessoires; aluminium, noir

↕ L 900, B 30, H 18

INCL. / INKL. / INCLUS



Connector to EASYT FEEDER
included.

Verbinder an EASYT FEEDER
enthalten.

Connecteur pour EASYT FEEDER
inclus.

901638

EASYT FEEDER

This adapter can be used with up
to 4 outputs.

Dieser Adapter kann mit bis zu
4 Ausgängen verwendet werden.

Cet adaptateur peut être utilisé
avec jusqu'à 4 sorties.



9008606323449



9008606323395

EASYT E27 ADAPTER

Use your own lights! With the EASYT E27 ADAPTER, almost any lampshade can be installed in the track system.

Verwenden Sie Ihre eigenen Leuchten! Mit dem EASYT E27 ADAPTER kann nahezu jeder Lampenschirm im Schienensystem verbaut werden.

Utilisez vos propres luminaires ! Avec EASYT E27 ADAPTER, il est possible d'installer pratiquement n'importe quel abat-jour dans le système de rails.

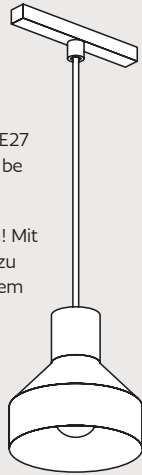

EASYT T-CONNECTOR

The EASYT T-CONNECTOR can also be used as a connector or power feed.

Der EASYT T-CONNECTOR kann auch als Verbinder oder Einspeisung fungieren.

Le EASYT T-CONNECTOR peut également faire office de connecteur ou d'alimentation.

EASYT CORNER

With the EASYT CORNER, rails can be connected at an angle of 75° - 180°.

Mit dem EASYT CORNER können Schienen im Winkel von 75° - 180° verbunden werden.

L'EASYT CORNER permet de relier des rails à un angle de 75° à 180°.



901642 EASYT CONNECTOR

accessory; plastic, black
Zubehör; Kunststoff, schwarz
Accessoires; plastique, noir

↕ L 74, B 30, H 18



9008606323463

901641 EASYT CORNER

accessory; plastic, black
Zubehör; Kunststoff, schwarz
Accessoires; plastique, noir

↕ L 187, B 30, H 18



9008606323456

902326 EASYT T-CONNECTOR

accessory; plastic, black
Zubehör; Kunststoff, schwarz
Accessoires; plastique, noir

↕ L 209, B 120, H 20



9008606358694



901642



901641



902326



901648



901647



901644

901648 EASYT SPOT RING

spot; plastic, black
Spot; Kunststoff, schwarz
spot; plastique, noir

↕ L 120, H 140, Ø 55



GU10

1 x
10 W

901647 EASYT SPOT TUBE

spot; plastic, black
Spot; Kunststoff, schwarz
spot; plastique, noir

↕ L 120, H 140, Ø 55



GU10

1 x
10 W

901644 EASYT E27 ADAPTER

pendant light; plastic, black
Hängeleuchte; Kunststoff, schwarz
luminaire en suspension; plastique, noir

↕ L 120, H 1000, Ø 58



E27

1 x
40 W



9008606323418



9008606323401



9008606323487



902691
NEW



902692
NEW



902626
NEW



902683
NEW

902626 EASYT SPHERE SPOT

track spots; plastic, black structure / matte-opal glass

Stromschienenspots; Kunststoff, schwarz-struktur / Glas opal-matt

spots sur rail conducteur; plastique, structure noire / verre opale mat

↳ L 120, H 135, Ø 100



G9

1 x
4,5W

902691 EASYT SPOT RIPPLE

track spots; plastic, matte brass

Stromschienenspots; Kunststoff, messing-matt

spots sur rail conducteur; plastique, laiton mat

↳ L 120, H 140, Ø 55



GU10

1 x
10 W

902692 EASYT SPOT RIPPLE

track spots; plastic, dark bronze

Stromschienenspots; Kunststoff, bronze dunkel

spots sur rail conducteur; plastique, bronze foncé

↳ L 120, H 140, Ø 55



GU10

1 x
10 W

902683 EASYT LONG DIFFUSO

track spots; plastic, black

Stromschienenspots; Kunststoff, schwarz

spots sur rail conducteur; plastique, noir

↳ L 305, B 30, H 70



LED

1 x
5 W

3
COLOUR
1 x
860lm



9008606389223



9008606392971



9008606392988



9008606389575

EASYT LONG DIFFUSO, EASYT FLAT SPOT

These luminaires have a CCT switch in the canopy to control the colour temperature.

Diese Leuchten verfügen über einen CCT-Schalter im Baldachin zur Steuerung der Farbtemperatur.

Ces luminaires disposent d'un interrupteur CCT dans le baldaquin pour contrôler la température de couleur.



901651



902628
NEW



902681
NEW



901651 EASYT PENDANT

pendant light; plastic, black
Hängeleuchte; Kunststoff, schwarz
luminaire en suspension; plastique, noir

⌋ L 120, H 1100, Ø 60



GU10



1 x
10 W



902681 EASYT FLAT SPOT

track spots; plastic, black
Stromschienenspots; Kunststoff, schwarz
spots sur rail conducteur; plastique, noir

⌋ L 120, H 115, Ø 100



1 x
3,8 W



1 x
450 lm



902628 EASYT SPHERE PENDA

pendant light; plastic, black matt / matte-opal glass

Hängeleuchte; Kunststoff, schwarz-matt / Glas opal-matt

luminaire en suspension; plastique, noir mat / verre opale mat

⌋ L 120, B 100, H 135, Ø 100



G9



1 x
4,5 W



EASYT PENDANT

You can easily shorten the cable of the EASYT PENDANT yourself.

Das Kabel der EASYT PENDANT Hängeleuchten kann einfach selbst gekürzt werden.

Le câble de la suspension EASYT PENDANT peut être facilement raccourci par l'utilisateur.



9008606323432



9008606389544



9008606389247



901668



901667

EASYT SET 4 SPOTS

Individually customizable.

Individuell anpassbar.

Personnalisable individuellement.

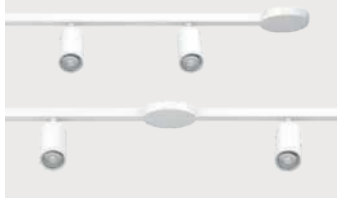

901668 EASYT SET 3 SPOTS

system; aluminium, plastic, white / plastic, white

System; Alu, Kunststoff, weiss / Kunststoff, weiss

système; aluminium, plastique, blanc / plastique, blanc

↳ L 1020, B 55, H 140



GU10



3 x
10 W

901667 EASYT SET 4 SPOTS

system; aluminium, plastic, white / plastic, white

System; Alu, Kunststoff, weiss / Kunststoff, weiss

système; aluminium, plastique, blanc / plastique, blanc

↳ L 1925, B 55, H 140



GU10



4 x
10 W



9008606323524



9008606323517



901655



901654

901655 EASYT FEEDER

accessory; plastic, white
Zubehör; Kunststoff, weiss
Accessoires; plastique, blanc

↕ H 20, Ø 120

901654 EASYT TRACK

accessory; aluminium, white
Zubehör; Alu, weiss
Accessoires; aluminium, blanc

↕ L 900, B 30, H 18

INCL. / INKL. / INCLUS



Connector to EASYT FEEDER
included.

Verbinder an EASYT FEEDER
enthalten.

Connecteur pour EASYT FEEDER
inclus.

901654

EASYT FEEDER

This adapter can be used with up
to 4 outputs.

Dieser Adapter kann mit bis zu
4 Ausgängen verwendet werden.

Cet adaptateur peut être utilisé
avec jusqu'à 4 sorties.



9008606323586



9008606323531

EASYT E27 ADAPTER

Use your own lights! With the EASYT E27 ADAPTER, almost any lampshade can be installed in the track system.

Verwenden Sie Ihre eigenen Leuchten! Mit dem EASYT E27 ADAPTER kann nahezu jeder Lampenschirm im Schienensystem verbaut werden.

Utilisez vos propres luminaires ! Avec EASYT E27 ADAPTER, il est possible d'installer pratiquement n'importe quel abat-jour dans le système de rails.

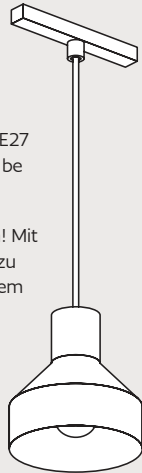

EASYT T-CONNECTOR

The EASYT T-CONNECTOR can also be used as a connector or power feed.

Der EASYT T-CONNECTOR kann auch als Verbinder oder Einspeisung fungieren.

Le EASYT T-CONNECTOR peut également faire office de connecteur ou d'alimentation.

EASYT CORNER

With the EASYT CORNER, rails can be connected at an angle of 75° - 180°.

Mit dem EASYT CORNER können Schienen im Winkel von 75° - 180° verbunden werden.

L'EASYT CORNER permet de relier des rails à un angle de 75° à 180°.



901657 EASYT CONNECTOR

accessory; plastic, white
Zubehör; Kunststoff, weiss
Accessoires; plastique, blanc

↯ L 74, B 30, H 18



9008606323609

901656 EASYT CORNER

accessory; plastic, white
Zubehör; Kunststoff, weiss
Accessoires; plastique, blanc

↯ L 187, B 30, H 18



9008606323593

902327 EASYT T-CONNECTOR

accessory; plastic, white
Zubehör; Kunststoff, weiss
Accessoires; plastique, blanc

↯ L 209, B 120, H 20



9008606358700



901657



901656

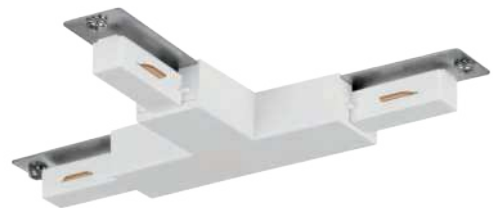

902327



901664



901659



901663

901664 EASYT SPOT RING

spot; plastic, white
Spot; Kunststoff, weiss
spot; plastique, blanc

901663 EASYT SPOT TUBE

spot; plastic, white
Spot; Kunststoff, weiss
spot; plastique, blanc

901659 EASYT E27 ADAPTER

pendant light; plastic, white
Hängeleuchte; Kunststoff, weiss
luminaire en suspension; plastique, blanc

↕ L 120, H 140, Ø 55



GU10

1 x
10 W

↕ L 120, H 140, Ø 55



GU10

1 x
10 W

↕ L 120, H 1000, Ø 58



E27

1 x
40 W



9008606323555



9008606323548



9008606323623



902871
NEW



902872
NEW



902627
NEW



902684
NEW

902627 EASYT SPHERE SPOT

track spots; plastic, white matt / matte-opal glass

Stromschienenspots; Kunststoff, weiss matt / Glas opal-matt

spots sur rail conducteur; plastique, blanc mat / verre opale mat

↻ L 120, H 135, Ø 100



G9

1 x
4,5W

902871 EASYT SPOT RIPPLE

track spots; plastic, matte brass

Stromschienenspots; Kunststoff, messing-matt

spots sur rail conducteur; plastique, laiton mat

↻ L 120, H 140, Ø 55



GU10

1 x
10 W

902872 EASYT SPOT RIPPLE

track spots; plastic, dark bronze

Stromschienenspots; Kunststoff, bronze dunkel

spots sur rail conducteur; plastique, bronze foncé

↻ L 120, H 140, Ø 55



GU10

1 x
10 W

902684 EASYT LONG DIFFUSO

track spots; plastic, white matt

Stromschienenspots; Kunststoff, weiss matt

spots sur rail conducteur; plastique, blanc mat

↻ L 305, B 30, H 70



LED

3
COLOUR

1 x
5 W

1 x
860lm



9008606389230



9008606399376



9008606399383



9008606389582

EASYT LONG DIFFUSO, EASYT FLAT SPOT

These luminaires have a CCT switch in the canopy to control the colour temperature.

Diese Leuchten verfügen über einen CCT-Schalter im Baldachin zur Steuerung der Farbtemperatur.

Ces luminaires disposent d'un interrupteur CCT dans le baldaquin pour contrôler la température de couleur.

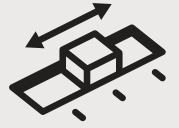

901666



902629
NEW



902682
NEW



901666 EASYT PENDANT

pendant light; plastic, white
Hängeleuchte; Kunststoff, weiss
luminaire en suspension; plastique, blanc

⌋ L 120, H 1100, Ø 60



GU10



1 x
10 W



902682 EASYT FLAT SPOT

track spots; plastic, white matt
Stromschienenspots; Kunststoff, weiss matt
spots sur rail conducteur; plastique, blanc mat

⌋ L 120, H 140, Ø 70



1 x
3,8 W



1 x
450 lm



902629 EASYT SPHERE PENDA

pendant light; plastic, white matt / matte-opal glass

Hängeleuchte; Kunststoff, weiss matt / Glas opal-matt

luminaire en suspension; plastique, blanc mat / verre opale mat

⌋ L 120, B 100, H 135, Ø 100



G9



1 x
4,5 W



EASYT PENDANT

You can easily shorten the cable of the EASYT PENDANT yourself.

Das Kabel der EASYT PENDANT Hängeleuchten kann einfach selbst gekürzt werden.

Le câble de la suspension EASYT PENDANT peut être facilement raccourci par l'utilisateur.



9008606323579



9008606389551



9008606389254

TRACK SYSTEM

TRACK PLUS

SCHIENENSYSTEM TRACK PLUS
SYSTÈMES DE RAIL TRACK PLUS

Advantages

- Extra flat track (6 mm)
- Wall and ceiling mounting
- Dimming and CCT by remote
- Controllable by group
- High lumen output
- Modern and innovative lighting solutions
- Ability to control brightness and light color for individual atmospheres

Vorteile

- Extra flache Schiene (6 mm)
- Wand- und Deckenmontage
- Dimmen und Steuerung per Fernbedienung
- Gruppenweise steuerbar
- Hoher Lumenausstoß
- Moderne und innovative Lichtlösungen
- Steuerung von Helligkeit und Lichtfarbe für individuelle Atmosphären

Avantages

- Rail extra plat (6 mm)
- Montage au mur et au plafond
- Gradation et contrôle par télécommande
- Contrôlable par groupe
- Rendement lumineux élevé
- Solutions d'éclairage modernes et innovantes
- Possibilité de contrôler la luminosité et la couleur de la lumière pour des ambiances personnalisées

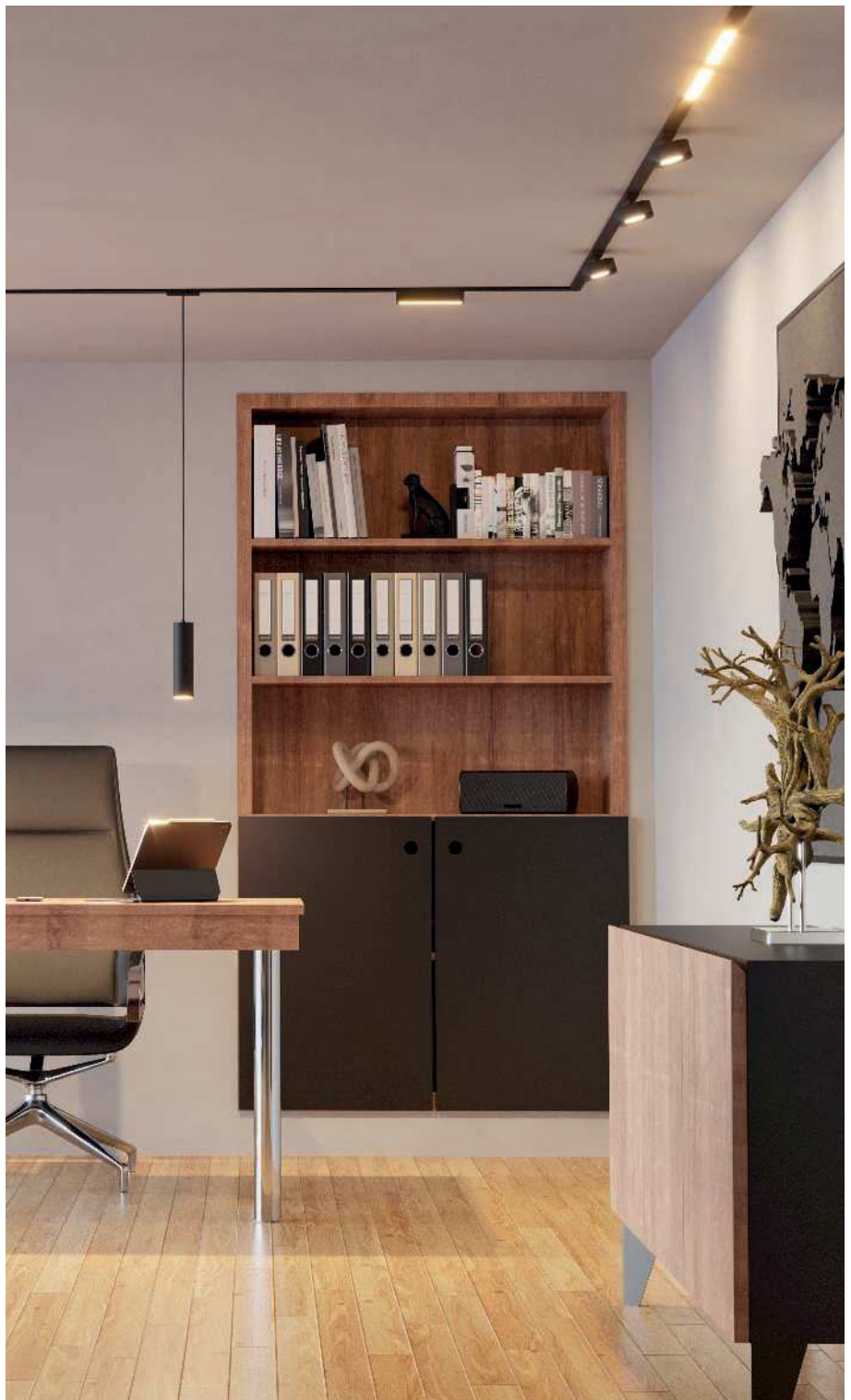

More Information on our website.
Mehr Informationen auf unserer Website.
Plus d'infos sur notre site web.

MAXIMUM FLEXIBILITY MAXIMALE FLEXIBILITÄT FLEXIBILITÉ MAXIMALE

With the TRACK PLUS solution you are able to fulfil multiple use cases:

- Wall and ceiling installation
- Power supply in deposed or directly to the track
- Creating L, T and X shapes with the included connectors
- The rail can be cut to size

Mit der TRACK PLUS-Lösung sind Sie in der Lage, mehrere Anwendungsfälle zu erfüllen:

- Wand- und Deckenmontage
- Stromzufuhr versetzt oder direkt an der Schiene
- Erstellen von L-, T- und X-Formen mit den mitgelieferten Verbindern
- Schiene individuell kürzbar

La solution TRACK PLUS permet de répondre à de multiples cas d'utilisation :

- Installation au mur et au plafond
- Alimentation électrique décalée ou directement sur le rail
- Créez des formes en L, T et X avec les connecteurs fournis
- Rail pouvant être raccourci sur mesure

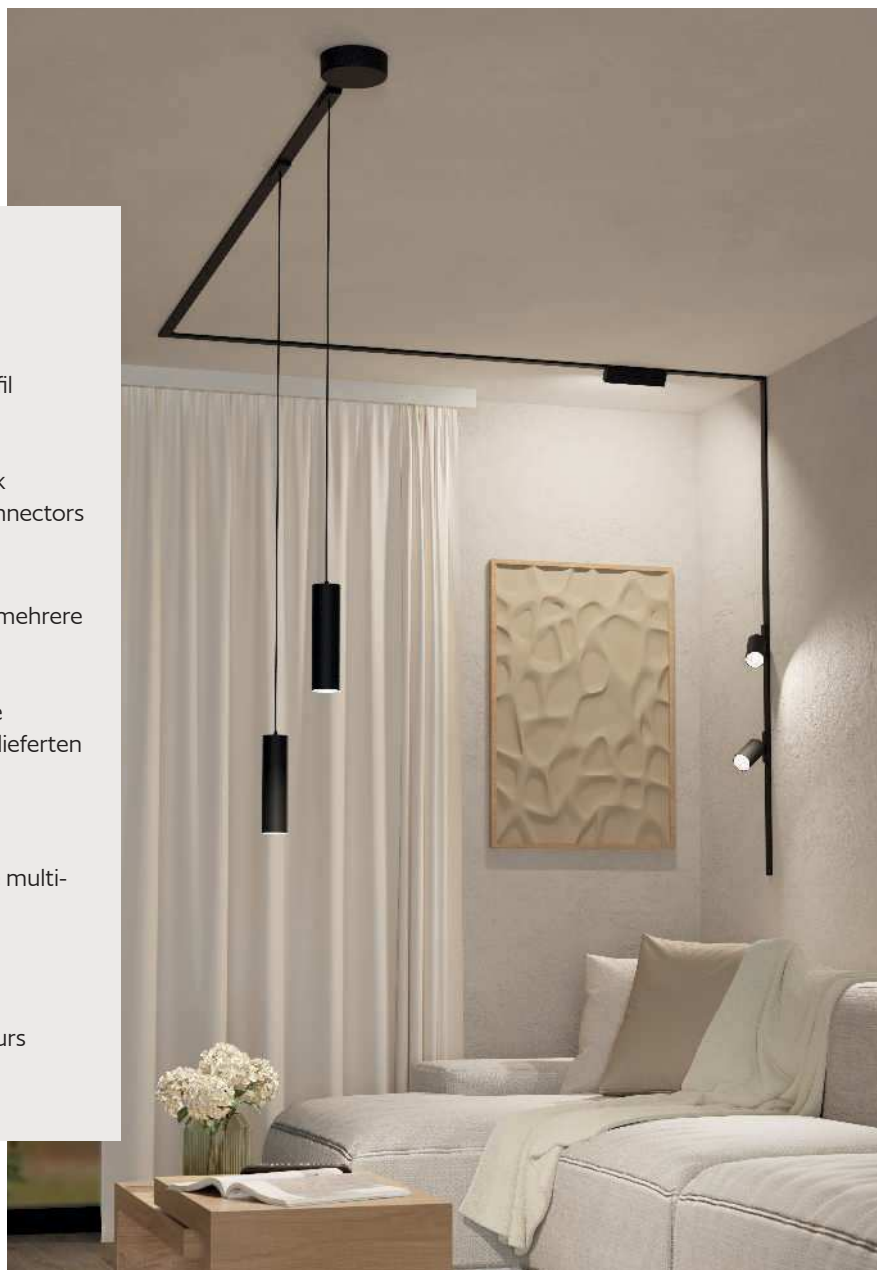

REMOTE CONTROLLABLE FERNSTEUERBAR CONTRÔLABLE À DISTANCE

- Timer (15 / 30 / 45 minutes)
 - Dimmable & Lightcolor change
 - Group selection (Group: A, B, A + B)
 - Favourites selection
-
- Timer (15 / 30 / 45 Minuten)
 - Dimmen & Lichtfarbenwechsel
 - Gruppenauswahl (Gruppe: A, B, A + B)
 - Favoritenauswahl
-
- Minuterie (15 / 30 / 45 minutes)
 - Dimmable et changement de couleur de lumière
 - Sélection de groupe (groupe : A, B, A + B)
 - Sélection des favoris







901753

INCL. / INKL. / INCLUS

- The starter set contains:
- 1 x remote control
 - 1 x track 0.95 m
 - 1 x driver (48 W) + connector for deported setup
 - 1 x ceiling to wall connector
 - 2 x covers
 - 2 x end cap

- Das Starter-Set enthält:
- 1 x Fernbedienung
 - 1 x Schiene 0,95 m
 - 1 x Treiber (48 W) + Verbinder für versetztes Netzteil
 - 1 x Wand-Decken-Verbinder
 - 2 x Abdeckungen
 - 2 x Endkappe

- Le kit de démarrage comprend :
- 1 x télécommande
 - 1 x rail de 0,95 m
 - 1 x driver (48 W) + connecteur pour installation déportée
 - 1 x connecteur plafond-mur
 - 2 x caches
 - 2 x embout

901753

1



901669

INCL. / INKL. / INCLUS

- The Extension set contains:
- 1 x rail 0.95 m
 - 2 x connectors (straight)
 - 1 x adjustable connector
 - 2 x covers
 - 1 x end cap

- Das Verlängerungs-Set enthält:
- 1 x Schiene 0,95 m
 - 2 x Verbinder (Gerade)
 - 1 x verstellbarer Verbinder
 - 2 x Abdeckungen
 - 1 x Endkappe

- Le kit de rallonge comprend:
- 1 x rail de 0,95 m
 - 2 x connecteurs (droit)
 - 1 x connecteur réglable
 - 2 x caches
 - 1 x embout

901669

2

901753 TPLUS STARTER SET

accessory; plastic, black
Zubehör; Kunststoff, schwarz
Accessoires; plastique, noir

↕ L 950, B 30, H 6

901669 TPLUS EXTENSION

accessory; plastic, black
Zubehör; Kunststoff, schwarz
Accessoires; plastique, noir

↕ L 1000, B 30, H 6



9008606329625



9008606323159

TPLUS

Choose among the 6 lighting modules to create your own atmosphere. Each CCT light can bring high lumen output, around 900 lumen.

Wählen Sie zwischen den 6 Beleuchtungsmodulen, um Ihre eigene Atmosphäre zu schaffen. Jedes CCT-Licht hat eine hohe Lichtausbeute von etwa 900 Lumen.

Choisissez parmi les 6 modules d'éclairage pour créer votre propre atmosphère. Chaque lumière CCT peut fournir un rendement lumineux élevé, d'environ 900 lumens.

3



901684



901683



901685

901684 TPLUS WIDE SPOT
track spots; plastic, black
Stromschienenspots; Kunststoff, schwarz
spots sur rail conducteur; plastique, noir

↕ L 120, H 40, Ø 85

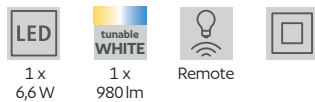

9008606323081

901683 TPLUS SLIM SPOT
track spots; plastic, black
Stromschienenspots; Kunststoff, schwarz
spots sur rail conducteur; plastique, noir

↕ L 120, H 140, Ø 55

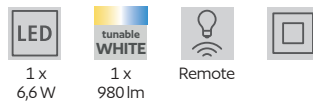

9008606323074

901685 TPLUS FLAT LIGHT
track spots; plastic, black
Stromschienenspots; Kunststoff, schwarz
spots sur rail conducteur; plastique, noir

↕ L 300, B 30, H 12

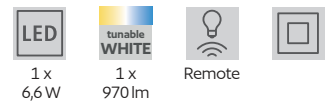

9008606323098



902687
NEW



901686



901687

902687 TPLUS SPHERE SPOT

spot; plastic, black / matte-opal glass, milky
Spot; Kunststoff, schwarz / Glas opal-matt, milky
spot; plastique, noir / verre opale mat, laiteux

⤴ H 115, Ø 105



1 x 6 W
1 x 980 lm

Remote

901686 TPLUS 6 LENS SPOT

track spots; plastic, black
Stromschienenspots; Kunststoff, schwarz
spots sur rail conducteur; plastique, noir

⤴ L 180, B 40, H 30



1 x 6,6 W
1 x 1000 lm

Remote

901687 TPLUS PENDANT

pendant light; plastic, black
Hängeleuchte; Kunststoff, schwarz
luminaire en suspension; plastique, noir

⤴ L 120, H 1100, Ø 55



1 x 6,6 W
1 x 980 lm

Remote



9008606392957



9008606323104



9008606323111





901754

INCL. / INKL. / INCLUS

- The starter set contains:
- 1 x remote control
 - 1 x track 0.95 m
 - 1 x driver (48 W) + connector for deported setup
 - 1 x ceiling to wall connector
 - 2 x covers
 - 2 x end cap

- Das Starter-Set enthält:
- 1 x Fernbedienung
 - 1 x Schiene 0,95 m
 - 1 x Treiber (48 W) + Verbinder für versetztes Netzteil
 - 1 x Wand-Decken-Verbinder
 - 2 x Abdeckungen
 - 2 x Endkappe

- Le kit de démarrage comprend :
- 1 x télécommande
 - 1 x rail de 0,95 m
 - 1 x driver (48 W) + connecteur pour installation déportée
 - 1 x connecteur plafond-mur
 - 2 x caches
 - 2 x embout

901754

1



901691

INCL. / INKL. / INCLUS

- The Extension set contains:
- 1 x rail 0.95 m
 - 2 x connectors (straight)
 - 1 x adjustable connector
 - 2 x covers
 - 1 x end cap

- Das Verlängerungs-Set enthält:
- 1 x Schiene 0,95 m
 - 2 x Verbinder (Gerade)
 - 1 x verstellbarer Verbinder
 - 2 x Abdeckungen
 - 1 x Endkappe

- Le kit de rallonge comprend:
- 1 x rail de 0,95 m
 - 2 x connecteurs (droit)
 - 1 x connecteur réglable
 - 2 x caches
 - 1 x embout

901691

2

901754 TPLUS STARTER SET

accessory; plastic, white
Zubehör; Kunststoff, weiss
Accessoires; plastique, blanc

↕ L 950, B 30, H 6

901691 TPLUS EXTENSION

accessory; plastic, white
Zubehör; Kunststoff, weiss
Accessoires; plastique, blanc

↕ L 1000, B 30, H 6



9008606329632



9008606323319

TPLUS

Choose among the 6 lighting modules to create your own atmosphere. Each CCT light can bring high lumen output, around 900 lumen.

Wählen Sie zwischen den 6 Beleuchtungsmodulen, um Ihre eigene Atmosphäre zu schaffen. Jedes CCT-Licht hat eine hohe Lichtausbeute von etwa 900 Lumen.

Choisissez parmi les 6 modules d'éclairage pour créer votre propre atmosphère. Chaque lumière CCT peut fournir un rendement lumineux élevé, d'environ 900 lumens.

3



901707



901706



901708

901707 TPLUS WIDE SPOT
track spots; plastic, white
Stromschienenspots; Kunststoff, weiss
spots sur rail conducteur; plastique, blanc

↕ L 120, H 40, Ø 85

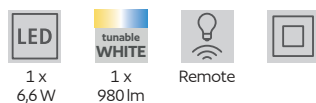

901706 TPLUS SLIM SPOT
track spots; plastic, white
Stromschienenspots; Kunststoff, weiss
spots sur rail conducteur; plastique, blanc

↕ L 120, H 140, Ø 55

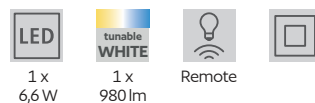

901708 TPLUS FLAT LIGHT
track spots; plastic, white
Stromschienenspots; Kunststoff, weiss
spots sur rail conducteur; plastique, blanc

↕ L 300, B 30, H 12

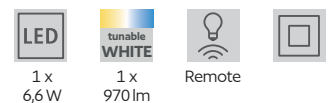



902688
NEW



901709



901711

902688 TPLUS SPHERE SPOT

spot; plastic, white matt / matte-opal glass, milky
Spot; Kunststoff, weiss matt / Glas opal-matt, milky
spot; plastique, blanc mat / verre opale mat, laiteux

H 115, Ø 105

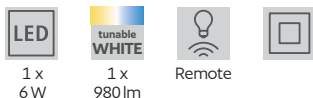

1 x
6 W

1 x
980 lm

Remote

901709 TPLUS 6 LENS SPOT

track spots; plastic, white
Stromschienenspots; Kunststoff, weiss
spots sur rail conducteur; plastique, blanc

L 180, B 40, H 30

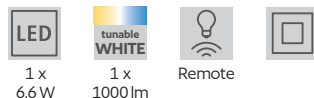

1 x
6,6 W

1 x
1000 lm

Remote

901711 TPLUS PENDANT

pendant light; plastic, white
Hängeleuchte; Kunststoff, weiss
luminaire en suspension; plastique, blanc

L 120, H 1100, Ø 55

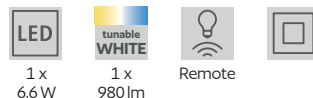

1 x
6,6 W

1 x
980 lm

Remote



9008606392964



9008606323265



9008606323272

LED PANEL LUMINAIRES

LED PANEELLEUCHTEN
LUMINAIRES PANNEAUX LED



EN

MODERN LED PANELS FOR UNIFORM LIGHT DESIGN

Clean lines, ultra-flat designs and even surface lighting – LED panels represent contemporary lighting with high functionality. Thanks to energy-efficient LED technology, they ensure low energy consumption and long-lasting performance. Whether in the living room, bedroom, home office, kitchen, hallway or basement – their versatile applications make them the ideal solution for a wide range of spaces and requirements. From simple on/off functions to innovative RGBW technology, modern LED panels offer flexible lighting moods for every situation. Available in various materials such as metal or plastic, they combine contemporary design with technical versatility.

DE

MODERNE LED PANELS FÜR FLÄCHIGES LICHTDESIGN

Klare Linien, flache Bauformen und gleichmäßiges Flächenlicht – LED Panels stehen für modernes Lichtdesign mit hoher Funktionalität. Dank energieeffizienter LED-Technologie überzeugen sie durch geringen Stromverbrauch und langlebige Performance. Ob im Wohnzimmer, Schlafzimmer, Homeoffice, in der Küche, im Flur oder im Keller – die vielseitigen Einsatzmöglichkeiten machen sie zur idealen Lösung für unterschiedlichste Räume und Anforderungen. Von klassischen Ein-/Aus-Funktionen bis hin zu innovativer RGBW-Technologie bieten moderne LED Panels flexible Lichtstimmungen für jede Situation. Erhältlich in verschiedenen Materialien wie Metall oder Kunststoff, verbinden sie zeitgemäßes Design mit technischer Vielfalt.

FR

PANNEAUX LED MODERNES POUR UN ÉCLAIRAGE HOMOGENÈME

Lignes épurées, formes extra-plates et éclairage uniforme – les panneaux LED incarnent un design lumineux moderne allié à une grande fonctionnalité. Grâce à la technologie LED économe en énergie, ils garantissent une faible consommation électrique et une longue durée de vie. Que ce soit dans le salon, la chambre, le bureau à domicile, la cuisine, le couloir ou la cave – leurs multiples possibilités d'utilisation en font une solution idéale pour de nombreux espaces et besoins. Des fonctions marche/arrêt classiques à la technologie innovante RGBW, les panneaux LED modernes permettent de créer des ambiances lumineuses flexibles pour chaque situation. Disponibles en différents matériaux tels que le métal ou le plastique, ils associent design contemporain et diversité technique.



LED PANEL FUNCTION

Item no. Art.-Nr. N° d'art.	Series name Seriename Nom de la série	Dimensions Größe Dimensions	Page Seite Page	neutral white neutralweiß blanc neutre	tunable white tunable white tunable white
901438	ROVITO	H 30, Ø 300	96		■
901439	ROVITO	H 30, Ø 389	96		■
901441	ROVITO	H 32, Ø 500	96		■
901442	ROVITO	L 290, B 290, H 30	97		■
901443	ROVITO	L 390, B 390, H 30	97		■
901444	ROVITO	L 500, B 500, H 32	97		■
901445	ROVITO	L 570, B 300, H 30	97		■
901446	ROVITO	H 30, Ø 300	98		■
901447	ROVITO	H 30, Ø 389	98		■
901448	ROVITO	H 32, Ø 500	98		■
901449	ROVITO	L 290, B 290, H 30	99		■
901451	ROVITO	L 390, B 390, H 30	99		■
901452	ROVITO	L 500, B 500, H 32	99		■
901453	ROVITO	L 570, B 300, H 30	99		■
901454	ROVITO-R	H 30, Ø 389	100		■
901455	ROVITO-R	H 32, Ø 500	100		■
901456	ROVITO-R	L 390, B 390, H 30	101		■
901457	ROVITO-R	L 500, B 500, H 32	101		■
901458	ROVITO-R	H 30, Ø 389	102		■
901459	ROVITO-R	H 32, Ø 500	102		■
901461	ROVITO-R	L 390, B 390, H 30	103		■
901462	ROVITO-R	L 500, B 500, H 32	103		■
901491	MORADILLO	L 393, B 393, H 61	104		■
901492	MORADILLO	L 595, B 595, H 61	104		■
901495	MORADILLO	L 1195, B 145, H 65	105		■
901494	MORADILLO	L 1195, B 295, H 61	105		■
902301	MORADILLO	L 1195, B 595, H 61	105		■
901488	MORADILLO	L 1195, B 145, H 65	106		■
901487	MORADILLO	L 1195, B 295, H 61	106		■
902369	MORADILLO	L 393, B 393, H 61	106		■
902371	MORADILLO	L 595, B 595, H 61	106		■
901504	MORADILLO-R	L 1195, B 145, H 65	107		■
902302	MORADILLO-R	L 1195, B 295, H 61	107		■
902303	MORADILLO-R	L 1195, B 595, H 61	107		■
902305	MORADILLO-R	L 595, B 595, H 61	107		■
32812	SALOBRENA 1	L 300, B 300, H 50	108	■	
98129	SALOBRENA 1	L 450, B 450, H 50	108	■	
32813	SALOBRENA 1	L 595, B 595, H 50	108	■	
98025	SALOBRENA 1	L 1195, B 100, H 45	109	■	
32811	SALOBRENA 1	L 1200, B 300, H 50	109	■	
900817	SALOBRENA 1	L 300, B 300, H 50	110	■	
900818	SALOBRENA 1	L 450, B 450, H 50	110	■	
900819	SALOBRENA 1	L 595, B 595, H 50	110	■	
900822	SALOBRENA 1	L 1195, B 100, H 45	111	■	
900821	SALOBRENA 1	L 1200, B 300, H 50	111	■	
96153	SALOBRENA 1	L 595, B 595, H 11	112	■	
96154	SALOBRENA 1	L 620, B 620, H 11	112	■	
96151	SALOBRENA 1	L 1200, B 300, H 11	112	■	
97502	SARSINA	H 50, Ø 450	114	■	
97503	SARSINA	H 50, Ø 600	114	■	
900937	RABASSA	L 595, B 595, H 27	115	■	
99836	TURCONA-CCT	L 1187, B 287, H 70	115		■

LED PANEL LUMINAIRES WITH FRAME

LED PANEELLEUCHTEN MIT RAHMEN

LUMINAIRES LED AVEC CADRE

Advantages

- Surface light with shadowless lighting
- Ultra-flat design
- Homogeneous surface lighting
- Simple installation
- Elegant suspension frame included
- Also suitable for flush mounting

Vorteile

- Flächiges Licht mit schattenfreier Ausleuchtung
- Ultraflaches Design
- Homogene Flächenausleuchtung
- Einfache Montage
- Inklusive elegantem Schweberrahmen
- Auch für flächenbündigen Einbau geeignet

Avantages

- Éclairage étalé avec éclairage sans ombre
- Design ultra plat
- Éclairage de surface homogène
- Montage simple
- Bâti flottant élégant inclus
- Adapté au montage encastré



ACCESSORIES

ZUBEHÖR

ACCESSOIRES

Accessories included

All luminaires include surface mounting solution.

Alle Leuchten beinhalten eine Lösung zur Deckenmontage.

Tous les luminaires incluent une solution de montage en surface.



Accessories optional

page | Seite | page: 113

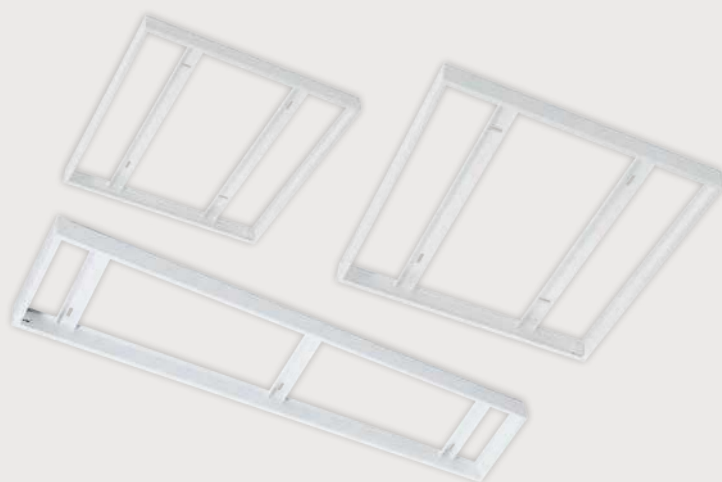

TECHNOLOGY
TECHNOLOGIE
TECHNOLOGIE

Discover the perfect lighting solution: MORADILLO panels use Backlight technology for uniform illumination. Or choose SALOBRENA panels with Sidelight technology, resulting in an ultra-slim design for a modern, elegant look.

Entdecken Sie die perfekte Beleuchtungslösung: MORADILLO Paneele nutzen Backlight-Technologie für eine gleichmäßige Ausleuchtung. Oder setzen Sie auf SALOBRENA Paneele mit Sidelight-Technologie und dadurch einem ultraflachen Design für eine moderne, elegante Optik.

Découvrez la solution d'éclairage parfaite : les panneaux MORADILLO utilisent la technologie Backlight pour un éclairage uniforme. Ou optez pour les panneaux SALOBRENA avec technologie Sidelight, offrant ainsi un design ultra-fin pour un look moderne et élégant.

MORADILLO | Backlight

- Even light distribution
- High energy efficiency
- Durable
- Gleichmäßige Lichtverteilung
- Hohe Energieeffizienz
- Langlebig
- Répartition uniforme de la lumière
- Haute efficacité énergétique
- Durable

SALOBRENA | Sidelight

- Ultra-slim design
- Lightweight and easy to install
- Pleasant, glare-free light
- Ultraflaches Design
- Leicht und einfach zu installieren
- Angenehmes, blendfreies Licht
- Design ultra-plat
- Léger et facile à installer
- Lumière agréable et sans éblouissement

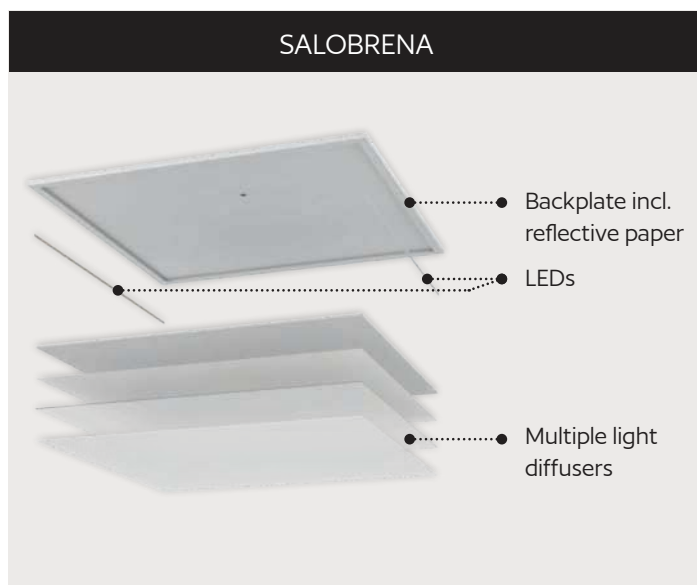

LIGHT COLOURS
LICHTFARBEN
COULEURS DE LUMIÈRE

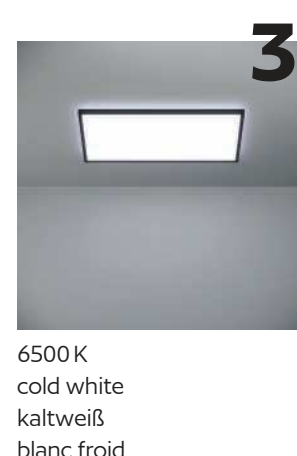

ROVITO

The ROVITO offers elegant indirect wall lighting. Thanks to the integrated dip switch, the light color can be individually adjusted before installation – selectable between warm white, neutral white, and cool white.

Die ROVITO bietet eine elegante, indirekte Wandbeleuchtung. Dank des integrierten Dipschalters kann die Lichtfarbe bereits vor der Montage individuell angepasst werden – wählbar zwischen Warmweiß, Neutralweiß und Kaltweiß.

La ROVITO offre un éclairage mural indirect et élégant. Grâce à l'interrupteur DIP intégré, la couleur de la lumière peut être ajustée individuellement avant l'installation – au choix entre blanc chaud, blanc neutre et blanc froid.

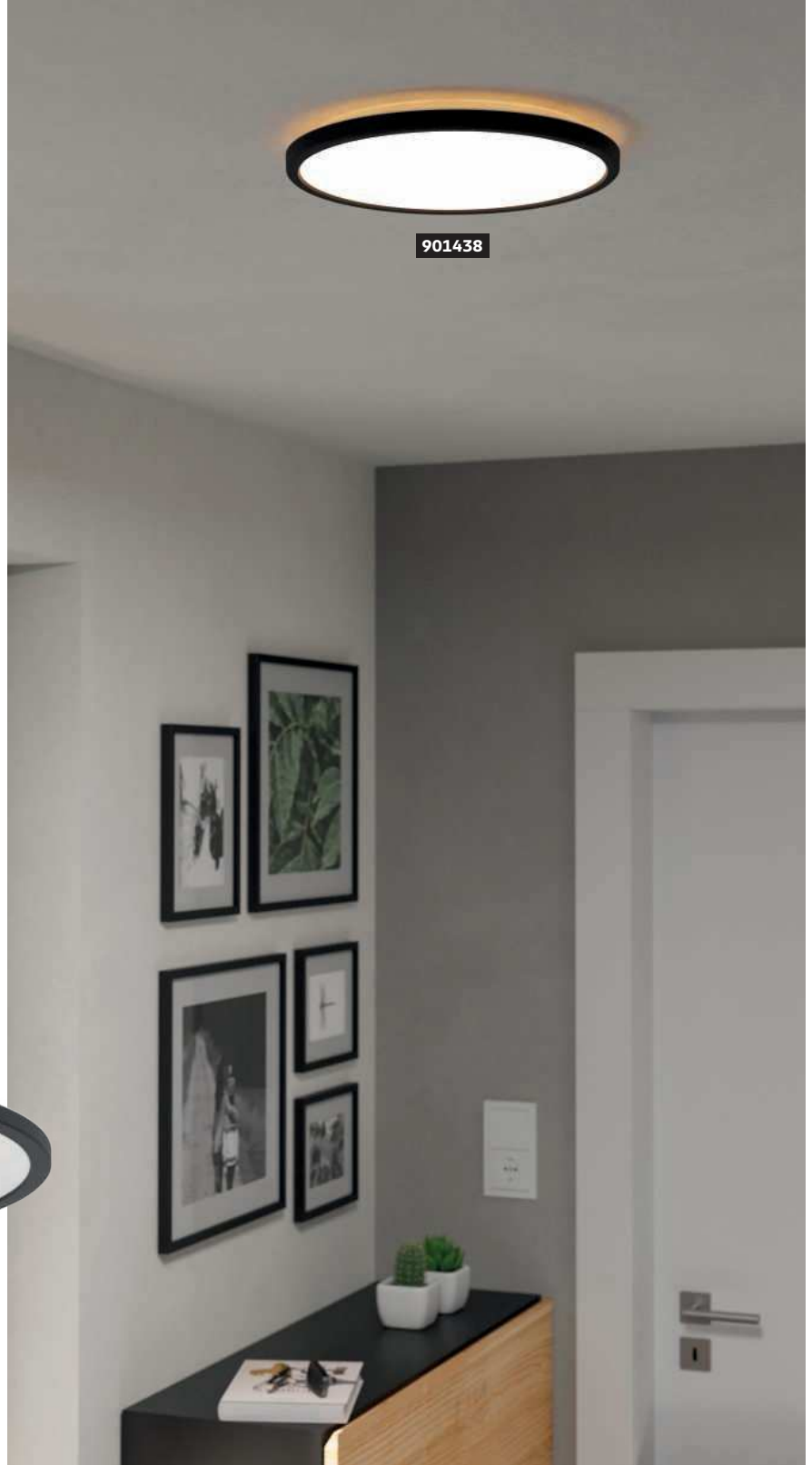

901439



901441



901439 ROVITO

ceiling light; plastic, black / plastic, white
Deckenleuchte; Kunststoff, schwarz / Kunststoff, weiss
plafonnier; plastique, noir / plastique, blanc

↕ H 30, Ø 389



1 x 18,5 W 1 x 2300 lm



IP44



9008606329854

901441 ROVITO

ceiling light; plastic, black / plastic, white
Deckenleuchte; Kunststoff, schwarz / Kunststoff, weiss
plafonnier; plastique, noir / plastique, blanc

↕ H 32, Ø 500



1 x 16,8 W 1 x 2900 lm



IP44



9008606329861

901438 ROVITO

ceiling light; plastic, black / plastic, white
Deckenleuchte; Kunststoff, schwarz / Kunststoff, weiss
plafonnier; plastique, noir / plastique, blanc

↕ H 30, Ø 300



1 x 13,9 W 1 x 1750 lm



IP44



9008606329847

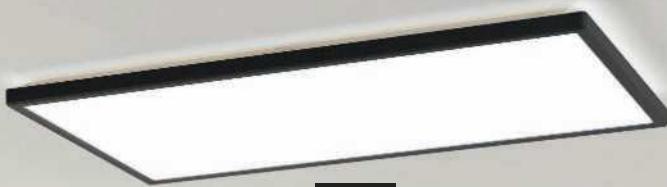

901445



901442



901443



901444

ROVITO

The light colour of these luminaires can be controlled in three steps.

Die Lichtfarbe dieser Leuchten können mittels Dip-Schalter in drei Stufen gesteuert werden.

La couleur de la lumière de ces luminaires peut être contrôlée en.



901445 ROVITO

ceiling light; plastic, black / plastic, white
Deckenleuchte; Kunststoff, schwarz / Kunststoff, weiss
plafonnier; plastique, noir / plastique, blanc

↕ L 570, B 300, H 30



1 x
17,2 W



1 x
2580 lm



IP44



9008606329908

901442 ROVITO

ceiling light; plastic, black / plastic, white
Deckenleuchte; Kunststoff, schwarz / Kunststoff, weiss
plafonnier; plastique, noir / plastique, blanc

↕ L 290, B 290, H 30



1 x
13,4 W



1 x
1780 lm



IP44



9008606329878

901443 ROVITO

ceiling light; plastic, black / plastic, white
Deckenleuchte; Kunststoff, schwarz / Kunststoff, weiss
plafonnier; plastique, noir / plastique, blanc

↕ L 390, B 390, H 30



1 x
17,6 W



1 x
2400 lm



IP44



9008606329885

901444 ROVITO

ceiling light; plastic, black / plastic, white
Deckenleuchte; Kunststoff, schwarz / Kunststoff, weiss
plafonnier; plastique, noir / plastique, blanc

↕ L 500, B 500, H 32



1 x
17 W



1 x
2800 lm



IP44



9008606329892



901447



901446



901448

ROVITO

The light colour of these luminaires can be controlled in three steps.

Die Lichtfarbe dieser Leuchten können mittels Dip-Schalter in drei Stufen gesteuert werden.

La couleur de la lumière de ces luminaires peut être contrôlée en.



901447 ROVITO

ceiling light; plastic, white / plastic, white
Deckenleuchte; Kunststoff, weiss / Kunststoff, weiss
plafonnier; plastique, blanc / plastique, blanc

↕ H 30, Ø 389



1 x 18,5 W 1 x 2300 lm



IP44



9008606329922

901446 ROVITO

ceiling light; plastic, white / plastic, white
Deckenleuchte; Kunststoff, weiss / Kunststoff, weiss
plafonnier; plastique, blanc / plastique, blanc

↕ H 30, Ø 300



1 x 13,9 W 1 x 1750 lm



IP44



9008606329915

901448 ROVITO

ceiling light; plastic, white / plastic, white
Deckenleuchte; Kunststoff, weiss / Kunststoff, weiss
plafonnier; plastique, blanc / plastique, blanc

↕ H 32, Ø 500



1 x 16,8 W 1 x 2900 lm



IP44



9008606329939



901451



901449



901453



901452



901451 ROVITO

ceiling light; plastic, white / plastic, white
Deckenleuchte; Kunststoff, weiss / Kunststoff, weiss
plafonnier; plastique, blanc / plastique, blanc

901449 ROVITO

ceiling light; plastic, white / plastic, white
Deckenleuchte; Kunststoff, weiss / Kunststoff, weiss
plafonnier; plastique, blanc / plastique, blanc

901452 ROVITO

ceiling light; plastic, white / plastic, white
Deckenleuchte; Kunststoff, weiss / Kunststoff, weiss
plafonnier; plastique, blanc / plastique, blanc

901453 ROVITO

ceiling light; plastic, white / plastic, white
Deckenleuchte; Kunststoff, weiss / Kunststoff, weiss
plafonnier; plastique, blanc / plastique, blanc

↕ L 390, B 390, H 30

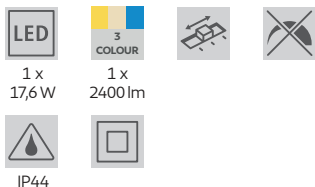

↕ L 290, B 290, H 30

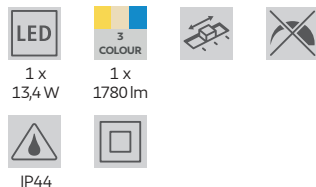

↕ L 500, B 500, H 32

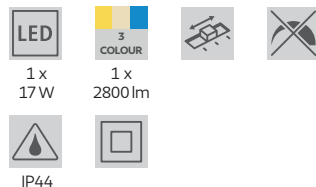

↕ L 570, B 300, H 30

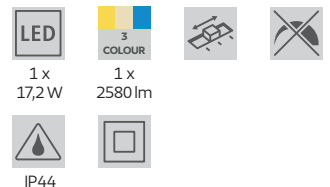

ROVITO-R

The ROVITO-R expands the possibilities of the ROVITO series with additional functions. With the included remote control, both the brightness and the color temperature can be flexibly controlled.

Die ROVITO-R erweitert die Möglichkeiten der ROVITO-Serie mit zusätzlichen Funktionen. Mit der mitgelieferten Fernbedienung lassen sich sowohl die Helligkeit als auch die Farbtemperatur flexibel steuern.

Le ROVITO-R élargit les possibilités de la série ROVITO avec des fonctions supplémentaires. Avec la télécommande incluse, la luminosité et la température de couleur peuvent être contrôlées de manière flexible.



901454



901455

901454 ROVITO-R

ceiling light; plastic, black / plastic, white

Deckenleuchte; Kunststoff, schwarz / Kunststoff, weiss

plafonnier; plastique, noir / plastique, blanc

901455 ROVITO-R

ceiling light; plastic, black / plastic, white

Deckenleuchte; Kunststoff, schwarz / Kunststoff, weiss

plafonnier; plastique, noir / plastique, blanc

H 30, Ø 389



1 x
18,5 W



1 x
2300 lm



Remote



IP44



H 32, Ø 500



1 x
16,8 W



1 x
2900 lm



Remote



IP44



9008606329984



9008606329991



901456

901457

ROVITO-R

These luminaires have individually controllable light settings on the inside and outside of the frame.

Diese Leuchten verfügen über individuell steuerbare Lichteinstellungen der Rahmen innen und außen.

Ces lumières ont des paramètres d'éclairage contrôlables individuellement du cadre.



901456 ROVITO-R

ceiling light; plastic, black / plastic, white
Deckenleuchte; Kunststoff, schwarz / Kunststoff, weiss
plafonnier; plastique, noir / plastique, blanc

↕ L 390, B 390, H 30



1 x 17,6 W
1 x 2400 lm



IP44



9008606330003

901457 ROVITO-R

ceiling light; plastic, black / plastic, white
Deckenleuchte; Kunststoff, schwarz / Kunststoff, weiss
plafonnier; plastique, noir / plastique, blanc

↕ L 500, B 500, H 32

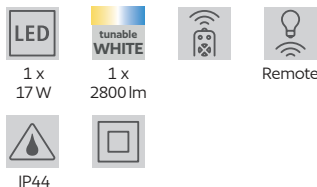

1 x 17 W
1 x 2800 lm



IP44



9008606330010

INCL. / INKL. / INCLUS



Included in the scope of delivery for the following items:

Bei folgenden Artikeln im Lieferumfang enthalten:

Les éléments suivants sont inclus dans la livraison :

901454, 901455, 901456, 901457





ROVITO-R

These luminaires have individually controllable light settings on the inside and outside of the frame.

Diese Leuchten verfügen über individuell steuerbare Lichteinstellungen der Rahmen innen und außen.

Ces lumières ont des paramètres d'éclairage contrôlables individuellement du cadre.



901459 ROVITO-R

ceiling light; plastic, white / plastic, white

Deckenleuchte; Kunststoff, weiss / Kunststoff, weiss

plafonnier; plastique, blanc / plastique, blanc

↕ H 32, Ø 500



1 x
16,8 W



1 x
2900 lm



Remote



IP44



9008606330034

901458 ROVITO-R

ceiling light; plastic, white / plastic, white

Deckenleuchte; Kunststoff, weiss / Kunststoff, weiss

plafonnier; plastique, blanc / plastique, blanc

↕ H 30, Ø 389



1 x
18,5 W



1 x
2300 lm



Remote



IP44



9008606330027



901461

INCL. / INKL. / INCLUS



Included in the scope of delivery for the following items:

Bei folgenden Artikeln im Lieferumfang enthalten:

Les éléments suivants sont inclus dans la livraison :

901458, 901459, 901461, 901462



901462

901461 ROVITO-R

ceiling light; plastic, white / plastic, white
Deckenleuchte; Kunststoff, weiss / Kunststoff, weiss
plafonnier; plastique, blanc / plastique, blanc

↕ L 390, B 390, H 30



1 x
17,6 W



1 x
2400 lm



Remote



IP44



9008606330041

901462 ROVITO-R

ceiling light; plastic, white / plastic, white
Deckenleuchte; Kunststoff, weiss / Kunststoff, weiss
plafonnier; plastique, blanc / plastique, blanc

↕ L 500, B 500, H 32



1 x
17 W



1 x
2800 lm



Remote



IP44



9008606330058



MORADILLO

Thanks to the integrated dip switch, the colour temperature of the backlight panel can be set individually before installation - selectable between warm white, neutral white and cool white.

Beim Backlight-Panel kann dank des integrierten Dipschalters die Farbtemperatur vor der Montage individuell eingestellt werden – wählbar zwischen Warmweiß, Neutralweiß und Kaltweiß.

Sur le panneau de rétroéclairage, la température de couleur peut être réglée individuellement avant le montage grâce au dip-switch intégré - au choix entre blanc chaud, blanc neutre et blanc froid.

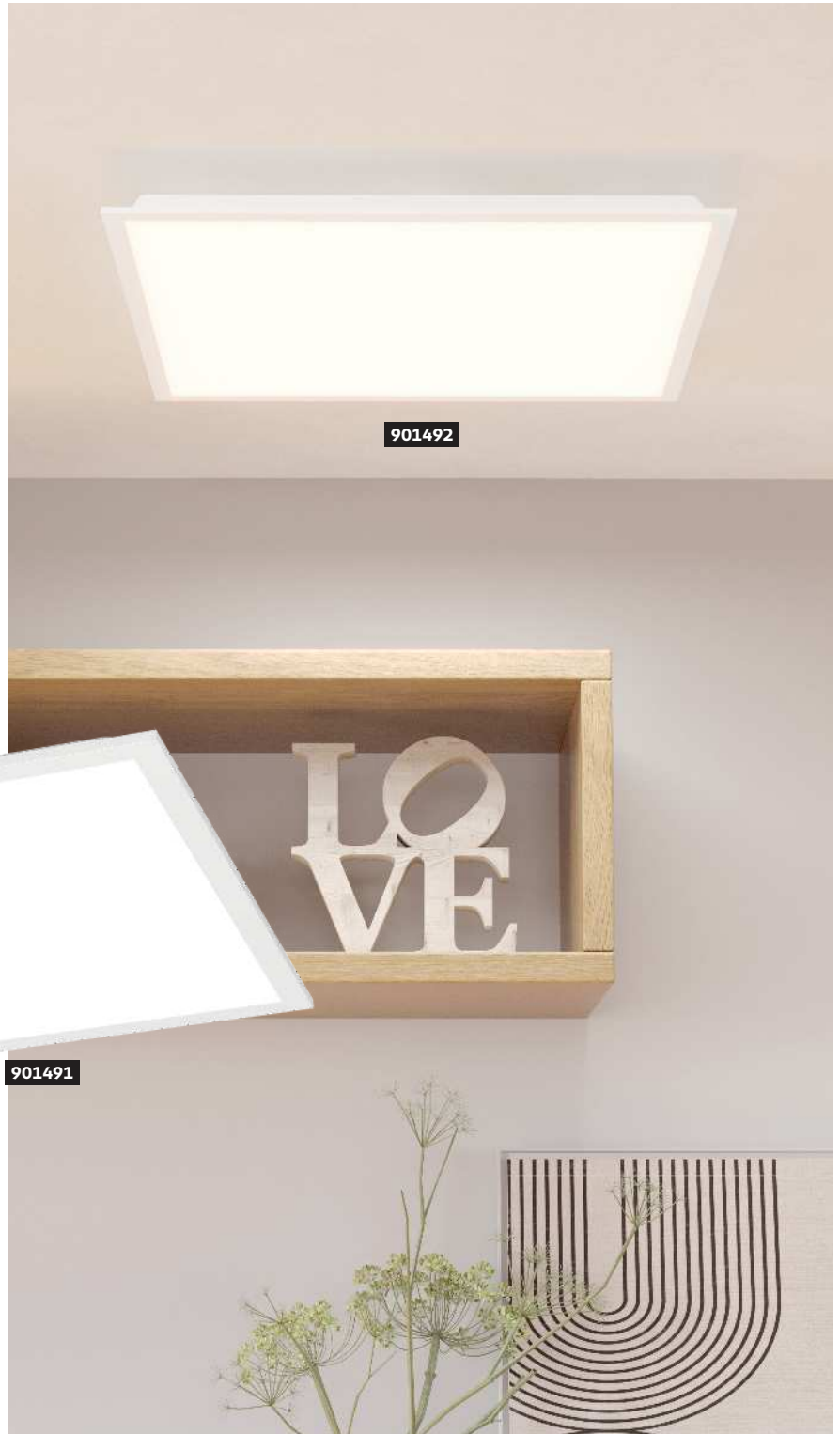

901492

901491

901491 MORADILLO

ceiling light; steel, white / plastic, white
Deckenleuchte; Stahl, weiss / Kunststoff, weiss
plafonnier; acier, blanc / plastique, blanc

↕ L 393, B 393, H 61



1 x 18,8 W



1 x 2300 lm



901492 MORADILLO

ceiling light; steel, white / plastic, white
Deckenleuchte; Stahl, weiss / Kunststoff, weiss
plafonnier; acier, blanc / plastique, blanc

↕ L 595, B 595, H 61



1 x 32,5 W



1 x 4350 lm



9008606340057



9008606340064

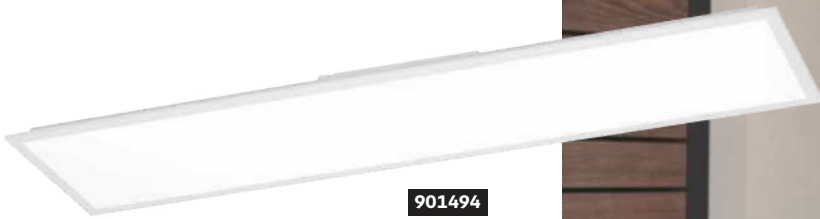
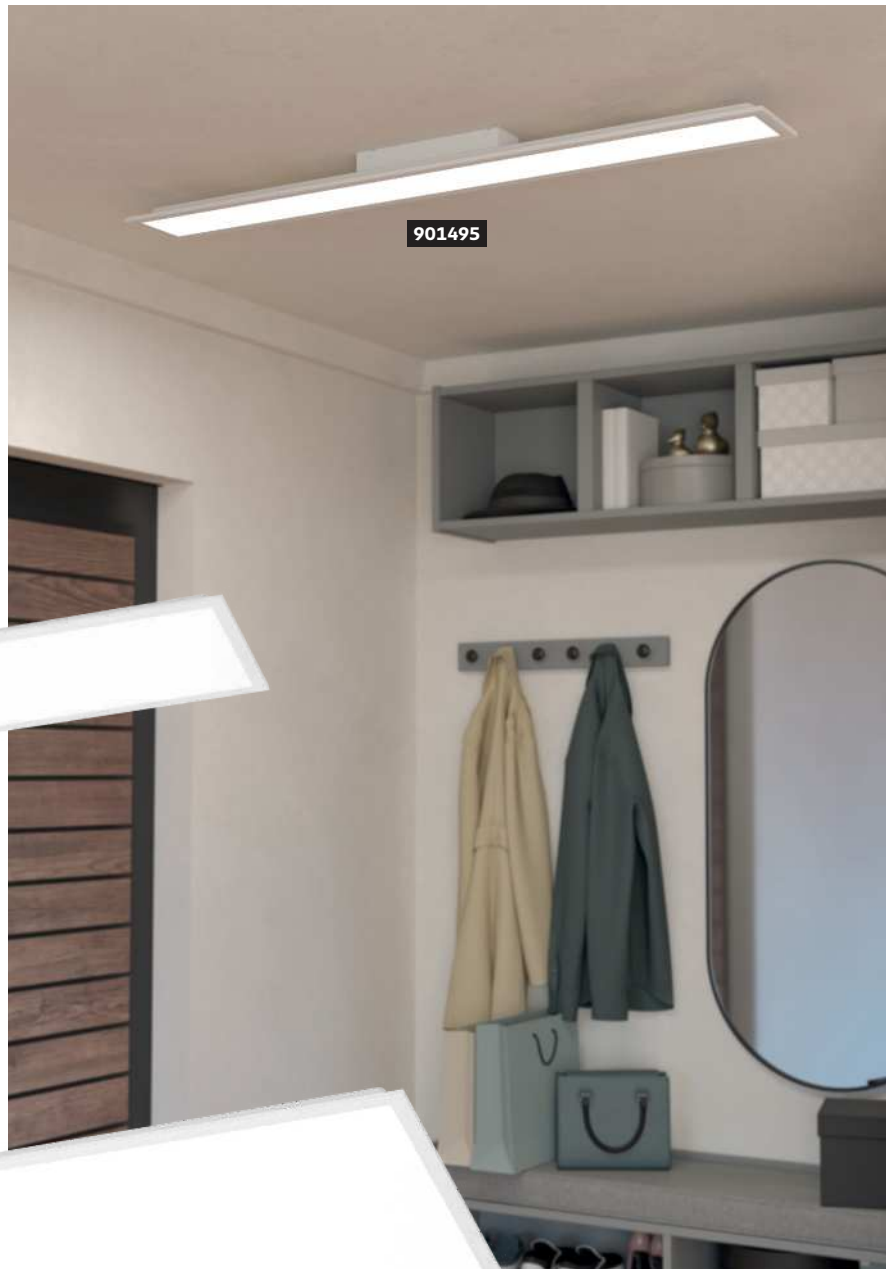

901494



902301

901494 MORADILLO

ceiling light; steel, white / plastic, white
 Deckenleuchte; Stahl, weiss / Kunststoff, weiss
 plafonnier; acier, blanc / plastique, blanc

↕ L 1195, B 295, H 61



902301 MORADILLO

ceiling light; steel, white / plastic, white
 Deckenleuchte; Stahl, weiss / Kunststoff, weiss
 plafonnier; acier, blanc / plastique, blanc

↕ L 1195, B 595, H 61



901495 MORADILLO

ceiling light; steel, white / plastic, white
 Deckenleuchte; Stahl, weiss / Kunststoff, weiss
 plafonnier; acier, blanc / plastique, blanc

↕ L 1195, B 145, H 65

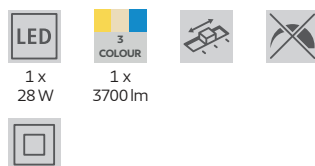

MORADILLO

Thanks to the integrated dip switch, the colour temperature of the backlight panel can be set individually before installation - selectable between warm white, neutral white and cool white.

Beim Backlight-Panel kann dank des integrierten Dipschalters die Farbtemperatur vor der Montage individuell eingestellt werden – wählbar zwischen Warmweiß, Neutralweiß und Kaltweiß.

Sur le panneau de rétroéclairage, la température de couleur peut être réglée individuellement avant le montage grâce au dip-switch intégré - au choix entre blanc chaud, blanc neutre et blanc froid.



901487 MORADILLO

ceiling light; steel, black / plastic, white
Deckenleuchte; Stahl, schwarz / Kunststoff, weiss
plafonnier; acier, noir / plastique, blanc

902371 MORADILLO

ceiling light; steel, black / plastic, white
Deckenleuchte; Stahl, schwarz / Kunststoff, weiss
plafonnier; acier, noir / plastique, blanc

902369 MORADILLO

ceiling light; steel, black / plastic, white
Deckenleuchte; Stahl, schwarz / Kunststoff, weiss
plafonnier; acier, noir / plastique, blanc

901488 MORADILLO

ceiling light; steel, black / plastic, white
Deckenleuchte; Stahl, schwarz / Kunststoff, weiss
plafonnier; acier, noir / plastique, blanc

↕ L 1195, B 295, H 61



↕ L 595, B 595, H 61



↕ L 393, B 393, H 61

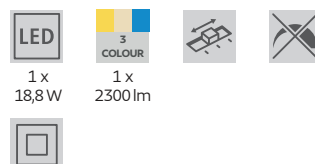

↕ L 1195, B 145, H 65

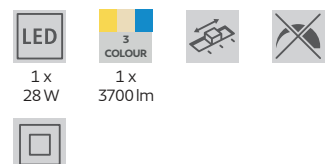

9008606340026



9008606369492



9008606369485



9008606340033



901504

MORADILLO-R

The MORADILLO-R expands the functionality of the Moradillo panel. With the included remote control, both the colour temperature (CCT technology) and brightness can be conveniently adjusted and controlled.

Die MORADILLO-R erweitert die Funktionalität des Moradillo-Panels. Mit der mitgelieferten Fernbedienung lassen sich sowohl die Farbtemperatur (CCT-Technologie) als auch die Helligkeit bequem einstellen und steuern.

Le MORADILLO-R étend la fonctionnalité du panneau Moradillo. Grâce à la télécommande fournie, il est possible de régler et de contrôler facilement à la fois la température de couleur (technologie CCT) et la luminosité.

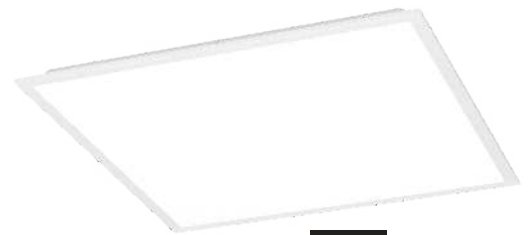

902305



902302



902303

INCL. / INKL. / INCLUS



Included in the scope of delivery for the following items:

Bei folgenden Artikeln im Lieferumfang enthalten:

Les éléments suivants sont inclus dans la livraison :

901504, 902302, 902303, 902305



901504 MORADILLO-R

ceiling light; steel, white / plastic, white
Deckenleuchte; Stahl, weiss / Kunststoff, weiss
plafonnier; acier, blanc / plastique, blanc

↕ L 1195, B 145, H 65



1 x
28,3W



1 x
3400lm



Remote



9008606340170

902305 MORADILLO-R

ceiling light; steel, white / plastic, white
Deckenleuchte; Stahl, weiss / Kunststoff, weiss
plafonnier; acier, blanc / plastique, blanc

↕ L 595, B 595, H 61



1 x
33W



1 x
4200lm



Remote



9008606358762

902302 MORADILLO-R

ceiling light; steel, white / plastic, white
Deckenleuchte; Stahl, weiss / Kunststoff, weiss
plafonnier; acier, blanc / plastique, blanc

↕ L 1195, B 295, H 61



1 x
33,5W



1 x
4300lm



Remote



9008606361694

902303 MORADILLO-R

ceiling light; steel, white / plastic, white
Deckenleuchte; Stahl, weiss / Kunststoff, weiss
plafonnier; acier, blanc / plastique, blanc

↕ L 1195, B 595, H 61



1 x
35,5W



1 x
5100lm



Remote



9008606361687

SALOBRENA 1

The SALOBRENA 1 is a high-quality sidelight panel that impresses with its high light output and fixed neutral white color temperature - the ideal lighting for work or living spaces.

Die SALOBRENA 1 ist ein hochwertiges Sidelight Panel und überzeugt mit einer hohen Lichtausbeute mit fester Farbtemperatur in Neutralweiß - die ideale Beleuchtung für Arbeits- oder Wohnbereiche.

SALOBRENA 1 est un panneau latéral de haute qualité qui se distingue par un rendement lumineux élevé et une température de couleur fixe en blanc neutre. Il constitue l'éclairage idéal pour les espaces de travail ou les pièces à vivre.



32812



32813

32812 SALOBRENA 1

ceiling light; aluminium, steel, white / plastic, white

Deckenleuchte; Alu, Stahl, weiss / Kunststoff, weiss

plafonnier; aluminium, acier, blanc / plastique, blanc

↻ L 300, B 300, H 50



1 x
14 W



1 x
2000 lm



32813 SALOBRENA 1

ceiling light; aluminium, steel, white / plastic, white

Deckenleuchte; Alu, Stahl, weiss / Kunststoff, weiss

plafonnier; aluminium, acier, blanc / plastique, blanc

↻ L 595, B 595, H 50



1 x
33 W



1 x
4700 lm



98129 SALOBRENA 1

ceiling light; aluminium, white / plastic, white

Deckenleuchte; Alu, weiss / Kunststoff, weiss

plafonnier; aluminium, blanc / plastique, blanc

↻ L 450, B 450, H 50



1 x
21,5 W



1 x
3000 lm



9002759328122



9002759328139



9002759981297



32811



98025

32811 SALOBRENA 1

ceiling light; aluminium, steel, white / plastic, white

Deckenleuchte; Alu, Stahl, weiss / Kunststoff, weiss

plafonnier; aluminium, acier, blanc / plastique, blanc

⌋ L 1200, B 300, H 50



1 x
33 W



1 x
4700 lm



98025 SALOBRENA 1

ceiling light; aluminium, white / plastic, white

Deckenleuchte; Alu, weiss / Kunststoff, weiss

plafonnier; aluminium, blanc / plastique, blanc

⌋ L 1195, B 100, H 45



1 x
38 W



1 x
4700 lm



9002759328115



9002759980252



900817 SALOBRENA 1

ceiling light; aluminium, steel, black / plastic, white

Deckenleuchte; Alu, Stahl, schwarz / Kunststoff, weiss

plafonnier; aluminium, acier, noir / plastique, blanc

L 300, B 300, H 50



1 x
14 W



1 x
2000 lm



900818 SALOBRENA 1

ceiling light; aluminium, black / plastic, white
Deckenleuchte; Alu, schwarz / Kunststoff, weiss

plafonnier; aluminium, noir / plastique, blanc

L 450, B 450, H 50



1 x
21,5 W



1 x
3000 lm



900819 SALOBRENA 1

ceiling light; aluminium, steel, black / plastic, white

Deckenleuchte; Alu, Stahl, schwarz / Kunststoff, weiss

plafonnier; aluminium, acier, noir / plastique, blanc

L 595, B 595, H 50



1 x
33 W



1 x
4700 lm



9008606259854



9008606259861



9008606259878



900822



900821

900822 SALOBRENA 1

ceiling light; aluminium, black / plastic, white
 Deckenleuchte; Alu, schwarz / Kunststoff, weiss
 plafonnier; aluminium, noir / plastique, blanc

⌋ L 1195, B 100, H 45



1 x 38 W
 1 x 4700 lm

900821 SALOBRENA 1

ceiling light; aluminium, steel, black / plastic, white
 Deckenleuchte; Alu, Stahl, schwarz / Kunststoff, weiss

plafonnier; aluminium, acier, noir / plastique, blanc

⌋ L 1200, B 300, H 50



1 x 33 W
 1 x 4700 lm



9008606259892



9008606259885

GRID LIGHTS: SALOBRENA 1

The SALOBRENA 1 Grid Light combines modern design with maximum functionality. Its slim profile and six flexible mounting options allow seamless integration into a wide variety of room concepts. Thanks to the homogeneous light distribution, it provides uniform and pleasant illumination.

Die SALOBRENA 1 Grid Light vereint modernes Design mit höchster Funktionalität. Ihre schlanke Bauform und die sechs flexiblen Montagevarianten ermöglichen eine nahtlose Integration in unterschiedlichste Raumkonzepte. Dank der homogenen Lichtverteilung sorgen sie für eine gleichmäßige und angenehme Ausleuchtung.

Le luminaire SALOBRENA 1 Grid Light allie un design moderne à une fonctionnalité maximale. Son format fin et ses six options de montage flexibles permettent une intégration harmonieuse dans de nombreux concepts d'aménagement. Grâce à une répartition homogène de la lumière, il assure un éclairage uniforme et agréable.

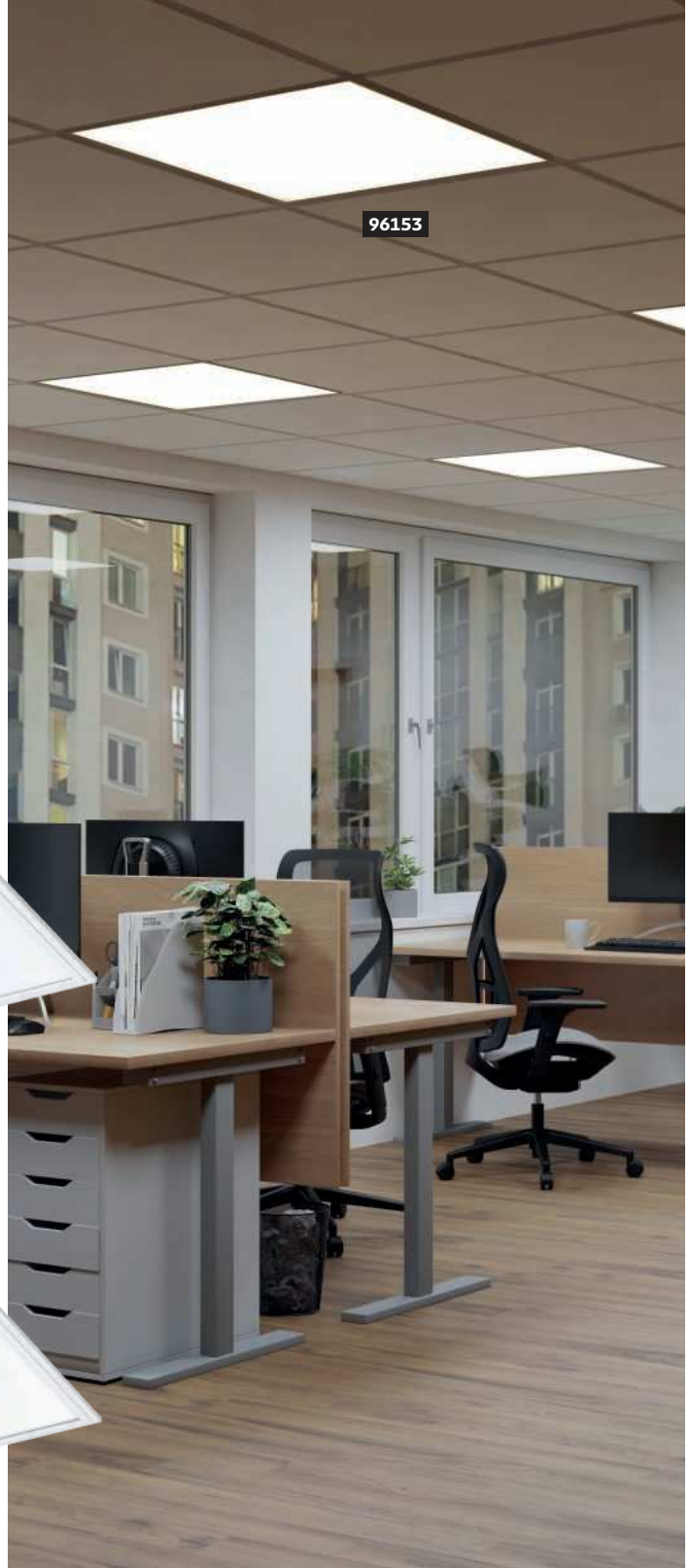

96151



96154

INCL./INKL./INCLUS



Included in the scope of delivery for the following items:

Bei folgenden Artikeln im Lieferumfang enthalten:

Les éléments suivants sont inclus dans la livraison :

96151, 96153, 96154

96151 SALOBRENA 1

grid light; aluminium, white / plastic, white
Rasterleuchte; Alu, weiss / Kunststoff, weiss
luminaire à grille; aluminium, blanc / plastique, blanc

⌋ L 1200, B 300, H 11



1 x
33 W



1 x
4700 lm



9002759961510

96154 SALOBRENA 1

grid light; aluminium, white / plastic, white
Rasterleuchte; Alu, weiss / Kunststoff, weiss
luminaire à grille; aluminium, blanc / plastique, blanc

⌋ L 620, B 620, H 11



1 x
35 W



1 x
4400 lm



9002759961541

96153 SALOBRENA 1

grid light; aluminium, white / plastic, white
Rasterleuchte; Alu, weiss / Kunststoff, weiss
luminaire à grille; aluminium, blanc / plastique, blanc

⌋ L 595, B 595, H 11



1 x
33 W



1 x
4700 lm



9002759961534

ACCESSORIES: SALOBRENA 1

The SALOBRENA 1 surface-mount frame made of white metal is an accessory for the matching LED panel, enabling easy and stable ceiling installation with an attractive appearance.

Der Aufbaurahmen SALOBRENA 1 aus weißem Metall ist ein Zubehör für das passende LED-Panel und ermöglicht eine einfache, stabile und optisch ansprechende Deckenmontage.

Le cadre de montage en surface SALOBRENA 1 en métal blanc est un accessoire pour le panneau LED assorti, permettant une installation au plafond simple, stable et esthétique.



61361



61358



61359

61361 SALOBRENA 1

accessory; steel, white
Zubehör; Stahl, weiss
Accessoires; acier, blanc

↕ L 303, B 1205, H 50

61358 SALOBRENA 1

accessory; steel, white
Zubehör; Stahl, weiss
Accessoires; acier, blanc

↕ L 603, B 603, H 50

61359 SALOBRENA 1

accessory; steel, white
Zubehör; Stahl, weiss
Accessoires; acier, blanc

↕ L 627, B 628, H 50



1

Grid luminaire
Rasterleuchte
Luminaire à Grille

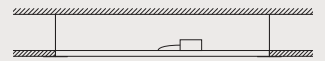

2

Recessed Luminaire
Einbauleuchte
Luminaire encastrée

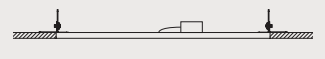

3

Semi-Recessed Luminaire
Semi-Einbauleuchte
Luminaire semi-encastrée



4

Surface Luminaire
Aufbauleuchte
Luminaire en saillie

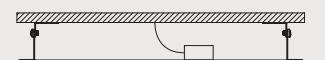

5

Frame Surface Luminaire
Rahmen Aufbauleuchte
Luminaire en saillie avec cadre

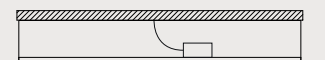

9002759613617



9002759613587



9002759613594

SARSINA

The SARSINA is the perfect choice for anyone who prefers uniform, neutral lighting. With their round design and high light output in neutral white, these luminaires create a pleasant lighting atmosphere.

Die SARSINA ist die perfekte Wahl für alle, die eine gleichmäßige, neutrale Beleuchtung bevorzugen. Mit dem runden Design und der hohen Lichtausbeute in Neutralweiß sorgen diese Leuchten für eine angenehme Lichtstimmung.

Le SARSINA est le choix parfait pour tous ceux qui préfèrent un éclairage uniforme et neutre. Avec leur design arrondi et leur rendement lumineux élevé en blanc neutre, ces luminaires créent une ambiance lumineuse agréable.



97503



97502

97503 SARSINA

ceiling light; aluminium, white / plastic, white
Deckenleuchte; Alu, weiss / Kunststoff, weiss
plafonnier; aluminium, blanc / plastique, blanc

H 50, Ø 600



1 x
36 W



1 x
5400 lm



97502 SARSINA

ceiling light; aluminium, white / plastic, white
Deckenleuchte; Alu, weiss / Kunststoff, weiss
plafonnier; aluminium, blanc / plastique, blanc

H 50, Ø 450



1 x
28 W



1 x
3800 lm



9002759975036



9002759975029

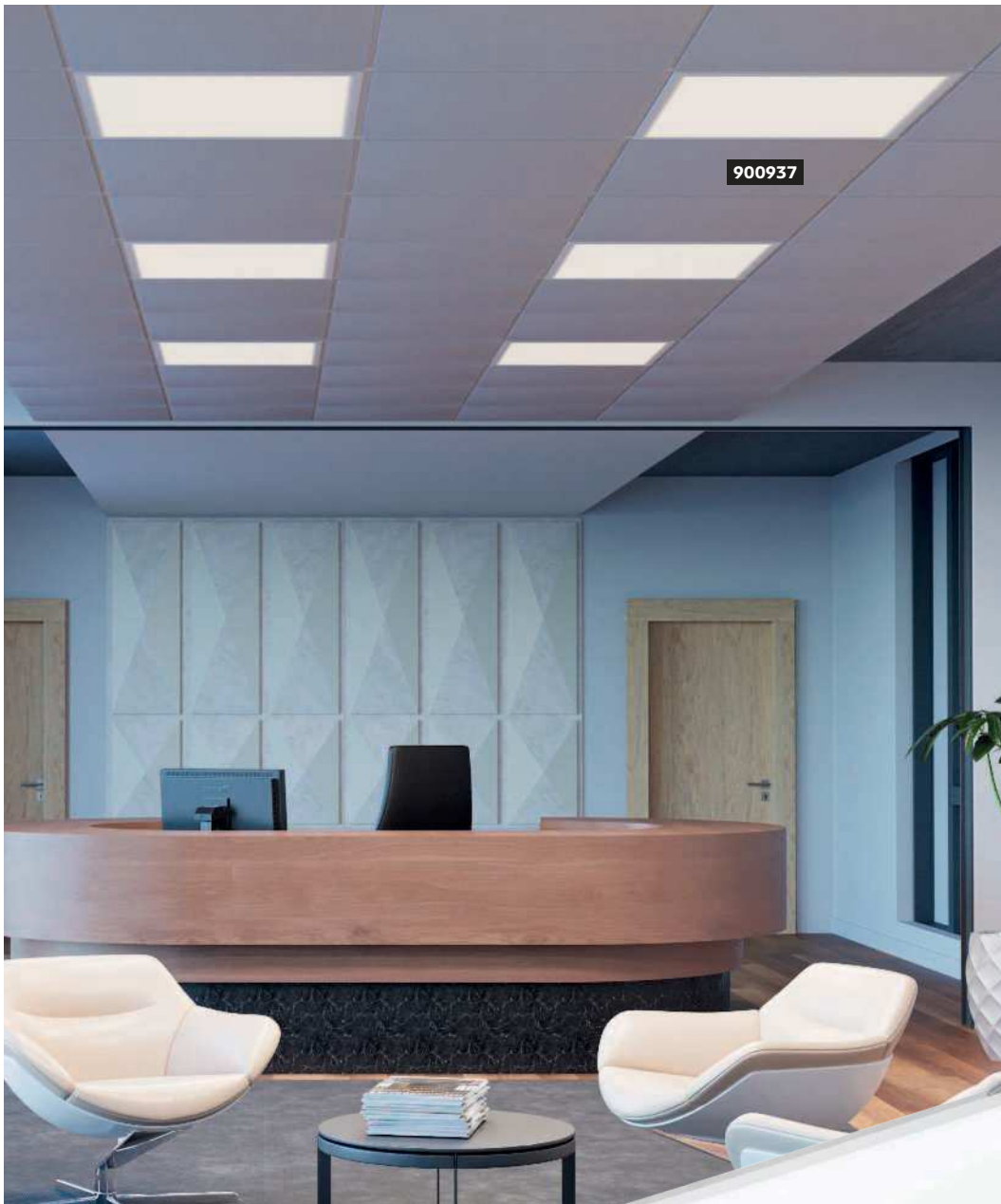

900937 RABASSA

grid light; aluminium, white / plastic, white
 Rasterleuchte; Alu, weiss / Kunststoff, weiss
 luminaire à grille; aluminium, blanc / plastique, blanc

↕ L 595, B 595, H 27



1 x 34,5W
 1 x 4900lm

99836 TURCONA-CCT

ceiling light; aluminium, steel, white / plastic, white
 Deckenleuchte; Alu, Stahl, weiss / Kunststoff, weiss
 plafonnier; aluminium, acier, blanc / plastique, blanc

↕ L 1187, B 287, H 70



1 x 32,4W
 1 x 3800lm

Remote



INCL. / INKL. / INCLUS



Suspension frame included in the scope of delivery for the following item:

Schweberahmen bei folgendem Artikel im Lieferumfang enthalten:

Cadre de suspension inclus dans la livraison pour l'article suivant :

99836

INCL. / INKL. / INCLUS



Included in the scope of delivery for the following item:

Bei folgendem Artikel im Lieferumfang enthalten:

L'élément suivant est inclus dans la livraison :

99836



9008606277872



9002759998363

RECESSED DOWNLIGHTS

EINBAULEUCHTEN

DOWNLIGHTS ENCASTRÉS



EN

DISCREET RECESSED LUMINAIRES FOR STYLISH LIGHTING ACCENTS

Subtle in design yet impactful in effect – recessed luminaires highlight your home in a refined and elegant way. Thanks to their minimalist appearance, they integrate seamlessly into ceilings and walls, creating a clean and modern look. Equipped with efficient LED technology or high-quality LED light sources, they stand out for low energy consumption, long service life and cost efficiency. Whether used for general lighting or targeted accents, recessed luminaires provide a simple and versatile solution for a wide range of living spaces.

DE

DEZENTE EINBAULEUCHTEN FÜR STILVOLLE LICHTAKZENTE

Unauffällig im Design und wirkungsvoll in der Inszenierung – Einbauleuchten setzen Ihr Zuhause dezent und zugleich stilvoll in Szene. Durch ihre zurückhaltende Optik fügen sie sich harmonisch in Decken und Wände ein und sorgen für ein modernes, aufgeräumtes Erscheinungsbild. Ausgestattet mit effizienter LED-Technologie oder hochwertigen LED-Leuchtmitteln überzeugen sie durch geringen Stromverbrauch, Langlebigkeit und Kosteneffizienz. Ob zur Grundbeleuchtung oder zur gezielten Akzentsetzung – Einbauleuchten bieten eine unkomplizierte und vielseitige Lösung für unterschiedlichste Wohnbereiche.

FR

SPOTS ENCASTRÉS DISCRETS POUR DES ACCENTS LUMINEUX ÉLÉGANTS

Discrets dans leur design et efficaces dans leur mise en scène – les luminaires encastrés subliment votre intérieur avec élégance. Grâce à leur apparence sobre, ils s'intègrent harmonieusement dans les plafonds et les murs et créent un rendu moderne et épuré. Équipés d'une technologie LED efficace ou de sources lumineuses LED de haute qualité, ils séduisent par leur faible consommation d'énergie, leur longue durée de vie et leur rentabilité. Qu'il s'agisse d'un éclairage général ou d'accents ciblés, les luminaires encastrés offrent une solution simple et polyvalente pour de nombreux espaces de vie.



RECESSED DOWNLIGHTS

HIGH- & LOW VOLTAGE

EINBAULEUCHTEN HOCH- & NIEDERVOLT
DOWNLIGHTS ENCASTRÉS HAUTE ET BASSE TENSION

Advantages

- Low mounting depth
- No transformer necessary - the latest LED high-voltage technology
- Ideal for lighting of rooms and areas
- Different functions available
- Low temperature enhances safety
- Up to 80% power savings compared to incandescent lamps, easy on your budget and the environment
- Easy and simple wiring by 2-fold junction box - easily expandable

Vorteile

- Geringe Einbautiefe
- Kein Trafo mehr notwendig – neueste LED Hochvolt Technologie
- Ideal zur Beleuchtung von Räumen und Flächen
- Unterschiedliche Funktionen verfügbar
- Geringe Wärmeentwicklung für mehr Sicherheit
- Bis zu 80% Stromersparnis gegenüber Glühlampen, schont Ihr Budget und die Umwelt
- Einfache und sichere Verkabelung durch 2-fach Anschlussbox – unkompliziert erweiterbar

Avantages

- Faible profondeur d'encastrement
- Plus besoin de transformateur - technologie LED haute tension la plus récente
- Idéal pour l'éclairage de pièces et de surfaces
- Différentes fonctions disponibles
- Faible dégagement de chaleur pour plus de sécurité
- Jusqu'à 80% d'économie d'électricité par rapport aux lampes à incandescence, préserve votre budget et l'environnement
- Câblage simple et sûr grâce à un boîtier de raccordement double - extensible facilement

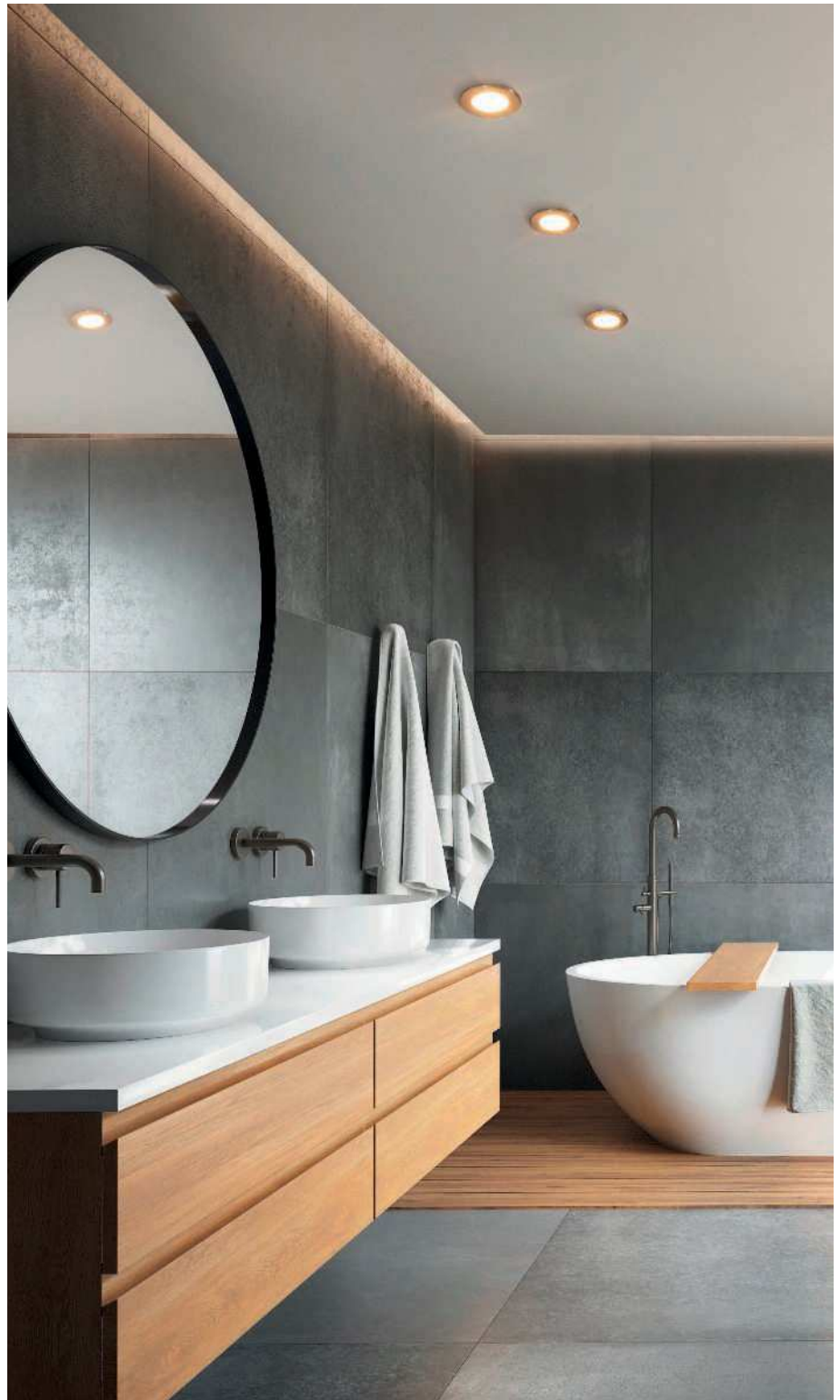

POS SOLUTION
 POS LÖSUNGEN
 SOLUTIONS POS

- The clear layout with intuitive symbols puts the products at the forefront without making the area feel cluttered, while also providing integrated product testing areas.
- Step-by-step explanation that makes the selection process as easy as possible for customers - from choosing the right IP class, installation depth restrictions and lumen output requirements to the desired additional features.
- Die übersichtliche Darstellung mit intuitiven Symbolen rückt die Produkte in den Vordergrund, ohne dass der Bereich überladen wirkt, und bietet gleichzeitig integrierte Produkttestflächen.
- Schritt-für-Schritt-Erklärung, die Kund:innen die Auswahl so einfach wie möglich macht – von der Wahl der richtigen IP-Klasse über Einschränkungen durch die Einbautiefe und Anforderungen an die Lumenstärke bis hin zu den gewünschten Zusatzfunktionen.
- La présentation claire avec des symboles intuitifs met les produits en avant sans surcharger l'espace, tout en offrant des zones de test intégrées pour les produits.
- Des explications étape par étape qui facilitent au maximum le choix des Client-es - du choix de la bonne classe IP aux caractéristiques supplémentaires souhaitées, en passant par les restrictions liées à la profondeur d'installation et aux exigences en matière d'intensité lumineuse.



INSTALLATION GUIDE
INSTALLATIONSHILFE
AIDE À L'INSTALLATION

1



SIMPLE INSTALLATION
EINFACHE MONTAGE
MONTAGE SIMPLE

Universally usable in walls or ceilings thanks to its small installation depth.

Durch die geringe Einbautiefe universell einsetzbar, ob Wand oder Decke.

Emploi universel dû à la faible profondeur de montage, que ce soit au mur ou au plafond.

QUICK AND SAFE CONNECTION
SCHNELLES UND SICHERES ANSCHLIESSEN
BRANCHEMENT RAPIDE ET SÛR

Easy wiring with the practical connection box. No transformer is needed anymore thanks to state-of-the-art high-voltage technology.

Leichtes Verkabeln durch die praktische Anschlussbox. Durch moderne Hochvolt-Technik wird kein Trafo mehr benötigt.

Câbler simplement avec le boîtier de branchement pratique. Grâce à la technique de haute tension moderne, plus besoin de transformateur.

2



PERFECT FIT
PERFEKTER HALT
MAINTIEN PARFAIT

The integrated holding brackets permit simple installation and guarantee for a precise fit.

Die integrierten Halteklammern ermöglichen einen einfachen Einbau und sorgen für garantierte Passgenauigkeit.

Les griffes de maintien intégrées permettent un montage simple et assurent un parfait ajustement.

3



FLUSH INSTALLATION
FLÄCHENBÜNDIGER EINBAU
MONTAGE À FLEUR

The slim build permits fitting installation in any surface.

Die schlanke Bauform ermöglicht den passenden Einbau bei jeder Fläche.

La structure fine permet le montage adéquat avec chaque surface.





ANTI-GLAIRE

ANTI-CLAIRE

AIDE À L'INSTALLATION

Recessed spotlights with a light source that is offset to the rear reduce glare, as the light does not fall directly into the eye. It is gently diffused, minimising reflections and increasing visual comfort - ideal for living spaces, offices and catering areas.

Einbauspots mit nach hinten versetzter Lichtquelle reduzieren Blendung, da das Licht nicht direkt ins Auge fällt. Es wird sanft gestreut, wodurch Reflexionen minimiert und der Sehkomfort erhöht wird - ideal für Wohnräume, Büros und Gastronomiebereiche.

Les spots encastrés dont la source lumineuse est décalée vers l'arrière réduit l'éblouissement, car la lumière ne tombe pas directement dans l'œil. Elle est diffusée en douceur, ce qui minimise les reflets et améliore le confort visuel - idéal pour les pièces d'habitation, les bureaux et les espaces de restauration.



Scan the QR code and start planning straight away!

Scannen Sie den QR-Code und starten Sie direkt mit der Planung!

Scannez le code QR et commencez directement à planifier !

EGLO LIGHT PLANNING TOOL

EGLO LICHTPLANNUNGSTOOL

EGLO OUTIL DE PLANIFICATION DE L'ÉCLAIRAGE

Perfect lighting made easy! Use our lighting planning tool to calculate the optimum number of lights for your room. Simply enter the article number, room size and room use (e.g. bathroom, study) - the tool will immediately provide you with a recommendation for perfect illumination.

Perfekte Beleuchtung leicht gemacht! Nutzen Sie unser Lichtplanungstool, um die optimale Anzahl an Leuchten für Ihren Raum zu berechnen. Einfach die Artikelnummer, die Raumgröße und die Raumnutzung (z. B. Badezimmer, Arbeitszimmer) eingeben – das Tool liefert Ihnen sofort eine Empfehlung für die perfekte Ausleuchtung.

Un éclairage parfait en toute simplicité ! Utilisez notre outil de planification de l'éclairage pour calculer le nombre optimal de luminaires pour votre pièce. Il suffit de saisir la référence, la taille de la pièce et son utilisation (par exemple salle de bains, bureau) - l'outil vous fournit immédiatement une recommandation pour un éclairage parfait.



PROTECTION CLASS OVERVIEW

SCHUTZKLASSENÜBERSICHT

APERÇU DES CLASSES DE PROTECTION

Detailed information on the protected areas in the bathroom and living area as well as an explanation of the IP classes can be found on page 4-5.

Detaillierte Informationen zu den Schutzbereichen im Badezimmer und Wohnbereich sowie eine Erklärung zu den IP-Klassen finden Sie auf Seite 4-5.

Vous trouverez des informations détaillées sur les zones de protection dans la salle de bains et le salon ainsi qu'une explication sur les classes IP à la page 4-5.



IP20













IP44



IP65











902338 PUCK CCT/DIM



 450 lm	 2700, 4000, 6500 K	
 H 27, Ø 55	 25000 h	
 4.8 W	 4.8 W ~ 64 W	
 LED	 80 CRI	
 dimmable		 9008606359059











902333 PUCK CCT



 500 lm	 2700, 4000, 6500 K	
 H 26, Ø 50	 25000 h	
 4.9 W	 4.9 W ~ 70 W	
 LED	 80 CRI	
 not dimmable		 9008606358977

902334 PUCK COB WW



 450 lm	 2700 K	
 H 41, Ø 50	 25000 h	
 4.8 W	 4.8 W ~ 64 W	
 LED	 80 CRI	
 dimmable		 9008606358984

EGLO PUCK











Our EGLO PUCKs are LED modules with different functions that can be easily replaced without having to replace the entire spotlight. This reduces waste and saves costs, as only individual modules need to be replaced. Compared to the classic GU10 light source, the EGLO PUCK also impresses with its particularly shallow installation depth - a practical and future-proof solution. More information on page 8-9.

Unsere EGLO PUCKs sind LED-Module mit unterschiedlichen Funktionen, die sich einfach austauschen lassen, ohne den gesamten Spot zu ersetzen. Das reduziert Abfall und spart Kosten, da nur einzelne Module nachgekauft werden müssen. Im Vergleich zum klassischen GU10-Leuchtmittel überzeugt der EGLO PUCK zudem durch eine besonders geringe Einbautiefe – eine praktische und zukunftssichere Lösung. Mehr Infos dazu auf Seite 8-9.

Nos EGLO PUCK sont des modules LED avec différentes fonctions qui peuvent être facilement remplacés sans avoir à remplacer le spot entier. Cela permet de réduire les déchets et de faire des économies, car seuls les modules individuels doivent être rachetés. Par rapport à une ampoule GU10 classique, le PUCK d'EGLO convainc en outre par sa profondeur d'encastrement particulièrement faible - une solution pratique et pérenne. Plus d'informations à la page 8-9.



902335 PUCK COB NW



 600 lm	 neutral 4000 K	 A ↑ G E
 H 41, Ø 50	 25000 h	
 6.4 W	 6.4 W ~ 83 W	
 LED	 80 CRI	
 dimmable		



9008606358991



902336 PUCK SMART RGB+TW

 440 lm	 2700-6500 K	 A ↑ G F
 H 46, Ø 50	 25000 h	
 4.7 W	 4.7 W ~ 63 W	
 LED	 80 CRI	
 dimmable via remote & app		



9008606359004



BASIC

BASIC

BASIQUE

- Cost-effective alternative: The Basic series offers solid quality at an affordable price - ideal for cost-conscious projects.
 - Practical and efficient bulk packaging: Optimised for bulk buyers and ideal for tradesmen or DIY enthusiasts who need multiple recessed spots.
 - Solid material for everyday use thanks to cost-efficient plastic housing: The lightweight and functional design is robust enough for everyday use while remaining affordable.
-
- Kostengünstige Alternative: Die Basic-Serie bietet solide Qualität zu einem erschwinglichen Preis – ideal für kostenbewusste Projekte.
 - Praktische und effiziente Großverpackungen: Optimiert für Großabnehmer und ideal für Handwerker oder Heimwerker, die mehrere Einbauspots benötigen.
 - Solides Material für den Alltag durch kosteneffizientes Kunststoffgehäuse: Das leichte und funktionale Design ist robust genug für den alltäglichen Einsatz und gleichzeitig preiswert.
-
- Alternative économique : la série Basic offre une qualité solide à un prix abordable - idéal pour les projets soucieux des coûts.
 - Emballage en vrac pratique et efficaces: Optimisé pour les gros acheteurs et idéal pour les artisans ou les bricoleurs qui ont besoin de plusieurs spots encastrables.
 - Un matériau solide pour le quotidien grâce à un boîtier en plastique économique : Le design léger et fonctionnel est suffisamment robuste pour une utilisation quotidienne tout en restant économique.

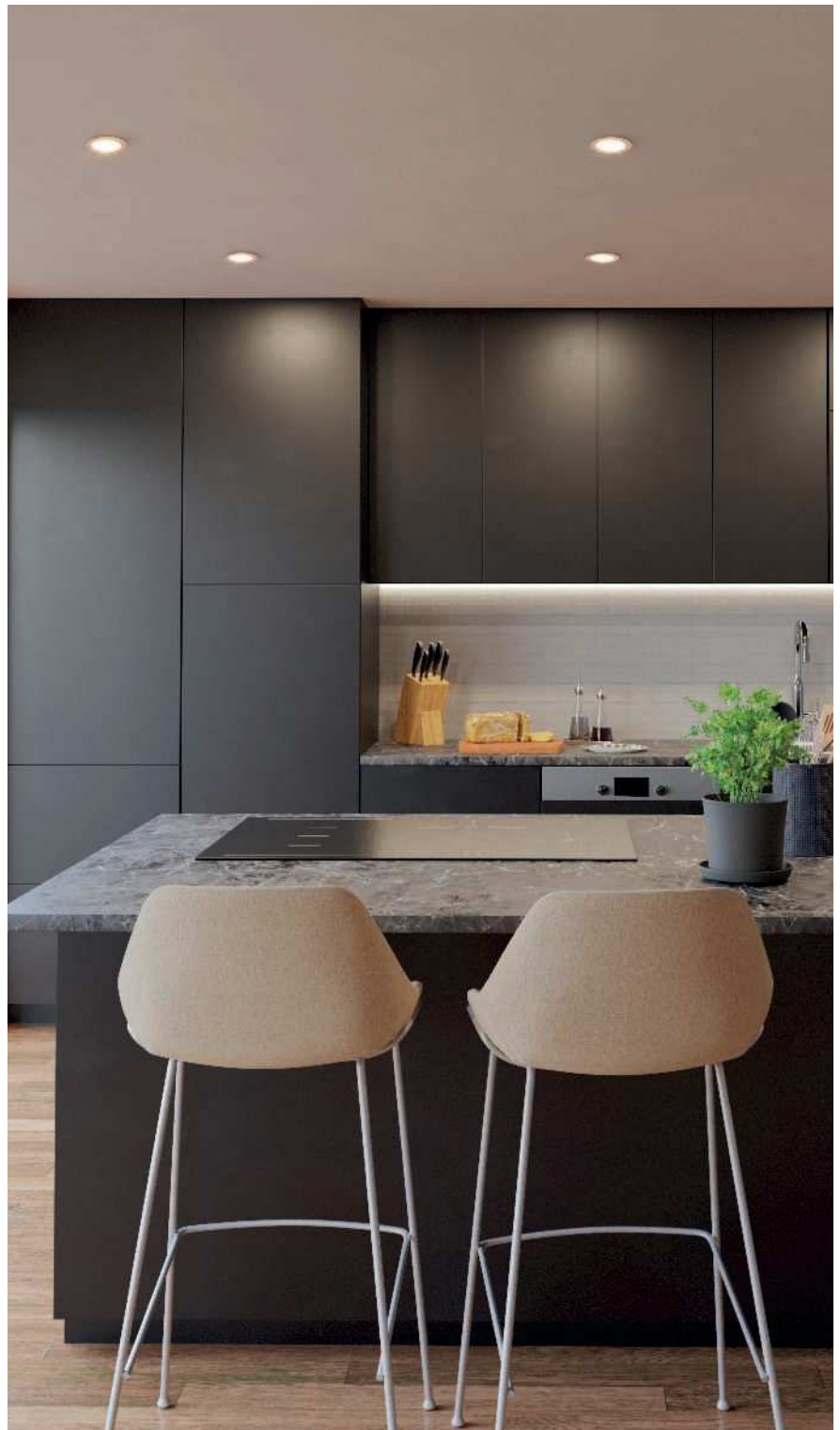

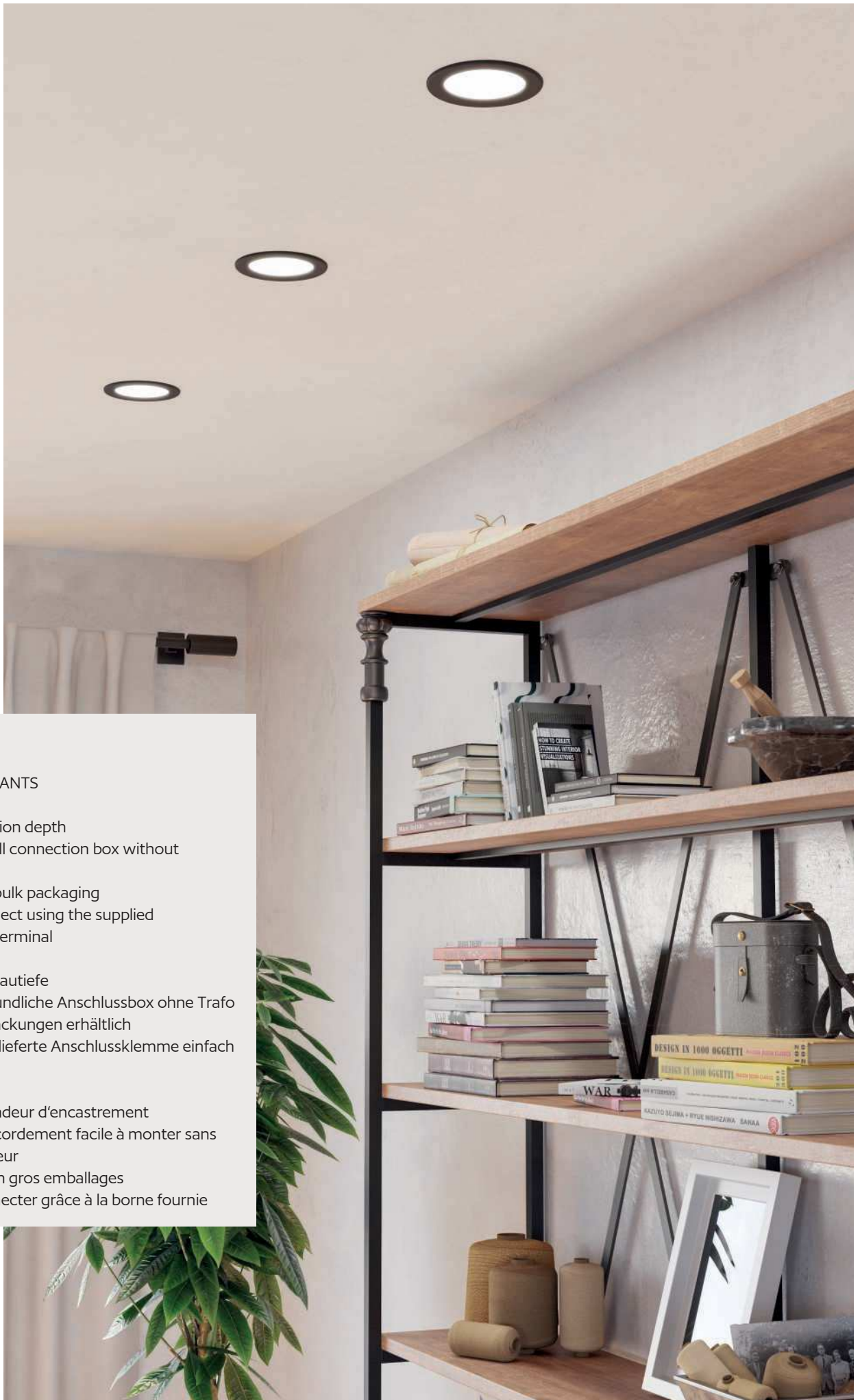

HIGHLIGHTS

HIGHLIGHTS

FAITS MARQUANTS

- Low installation depth
- Easy to install connection box without transformer
- Available in bulk packaging
- Easy to connect using the supplied connection terminal

- Geringe Einbautiefe
- Montagefreundliche Anschlussbox ohne Trafo
- In Großverpackungen erhältlich
- Durch mitgelieferte Anschlussklemme einfach verbindbar







































- Faible profondeur d'encastrement
- Boîte de raccordement facile à monter sans transformateur
- Disponible en gros emballages
- Facile à connecter grâce à la borne fournie



GEDREZ

recessed light
Einbauleuchte
luminaire encastrable



Material / Colour	Size	Cutout	Watt	Lumen	Quantity	Material-Nr.	EAN code
 plastic, white / plastic, transparent Kunststoff, weiss / Kunststoff, transparent plastique, blanc / plastique, transparent	Ø 90, ET 25	Ø 68	3 x 4,9 W	 3 x 520 lm		3	300184  9008606346639
	Ø 90, ET 25	Ø 68	5 x 4,9 W	 5 x 520 lm		5	300185  9008606346646
	Ø 90, ET 25	Ø 68	7 x 4,9 W	 7 x 520 lm		7	300186  9008606346653
	Ø 90, ET 25	Ø 68	10 x 4,9 W	 10 x 520 lm		10	300187  9008606346660
 plastic, satin nickel / plastic, transparent Kunststoff, nickel-matt / Kunststoff, transparent plastique, nickel mat / plastique, transparent	Ø 90, ET 25	Ø 68	3 x 4,9 W	 3 x 520 lm		3	300193  9008606346714
	Ø 90, ET 25	Ø 68	5 x 4,9 W	 5 x 520 lm		5	300194  9008606346721
	Ø 90, ET 25	Ø 68	7 x 4,9 W	 7 x 520 lm		7	300195  9008606346738
	Ø 90, ET 25	Ø 68	10 x 4,9 W	 10 x 520 lm		10	300196  9008606346745
 plastic, black / plastic, transparent Kunststoff, schwarz / Kunststoff, transparent plastique, noir / plastique, transparent	Ø 90, ET 25	Ø 68	3 x 4,9 W	 3 x 520 lm		3	300188  9008606346677
	Ø 90, ET 25	Ø 68	5 x 4,9 W	 5 x 520 lm		5	300189  9008606346684
	Ø 90, ET 25	Ø 68	7 x 4,9 W	 7 x 520 lm		7	300191  9008606346691
	Ø 90, ET 25	Ø 68	10 x 4,9 W	 10 x 520 lm		10	300192  9008606346707



BARRANCO

recessed light
Einbauleuchte
luminaire encastrable



BARRANCO

Replaceable bulb, compatible with:

Leuchtmittel tauschbar, kompatibel mit:

Ampoule interchangeable, compatible avec :































- > PUCK CCT
- > PUCK CCT/DIM
- > PUCK COB WW
- > PUCK COB NW
- > PUCK SMART RGB+TW

Learn more on pages 8-9.

Mehr erfahren Sie auf den Seiten 8-9.

En savoir plus aux pages 8-9.



Material / Colour	Size	Cutout	Watt	Lumen	Quantity	Material-Nr.	EAN code
 plastic, white Kunststoff, weiss plastique, blanc	Ø 90, ET 30	Ø 68	4,5 W	 450 lm		1	902261  9008606359394
	Ø 90, ET 30	Ø 68	3 x 4,5 W	 3 x 450 lm		3	902262  9008606359424
	Ø 90, ET 30	Ø 68	5 x 4,5 W	 5 x 450 lm		5	902263  9008606359455
 plastic, satin nickel Kunststoff, nickel-matt plastique, nickel mat	Ø 90, ET 30	Ø 68	4,5 W	 450 lm		1	902267  9008606359417
	Ø 90, ET 30	Ø 68	3 x 4,5 W	 3 x 450 lm		3	902268  9008606359448
	Ø 90, ET 30	Ø 68	5 x 4,5 W	 5 x 450 lm		5	902269  9008606359479
 plastic, black Kunststoff, schwarz plastique, noir	Ø 90, ET 30	Ø 68	4,5 W	 450 lm		1	902264  9008606359400
	Ø 90, ET 30	Ø 68	3 x 4,5 W	 3 x 450 lm		3	902265  9008606359431
	Ø 90, ET 30	Ø 68	5 x 4,5 W	 5 x 450 lm		5	902266  9008606359462

FUEVA 6

Our FUEVA 6 offers numerous advantages:

- Quick and easy installation thanks to quick-connect system
- Robust and durable frame
- Clean and modern design
- High lumen output for optimum lighting
- Three light colors adjustable via dip switch

Unsere FUEVA 6 bietet zahlreiche Vorteile:

- Einfache und schnelle Installation durch Schnellanschluss
- Robuster und langlebiger Rahmen
- Sauberes und modernes Design
- Hohe Lumen-Ausbeute für optimale Beleuchtung
- Drei Lichtfarben mittels Dip-Schalter einstellbar

Notre FUEVA 6 offre de nombreux avantages :



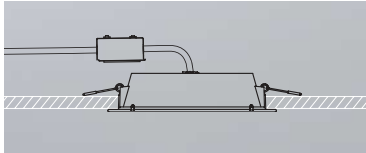

























- Installation simple et rapide grâce au raccordement rapide
- Cadre robuste et durable
- Design propre et moderne
- Rendement en lumens élevé pour un éclairage optimal
- Trois couleurs de lumière réglables au moyen d'un dip-switch



FUEVA 6

recessed light
Einbauleuchte
luminaire encastrable



Material / Colour	Size	Cutout	Watt	Lumen	IP class	Quantity	Material-Nr.	EAN code
 plastic, white / plastic, white Kunststoff, weiss / Kunststoff, weiss plastique, blanc / plastique, blanc	Ø 88, ET 40	Ø 75	3,7 W	 450 lm		1	901395	 9008606330751
	Ø 88, ET 40	Ø 75	3 x 3,7 W	 3 x 450 lm		3	901394	 9008606330744
	Ø 88, ET 40	Ø 75	3,7 W	 450 lm	  IP44	1	901416	 9008606330935
 plastic, satin nickel / plastic, white Kunststoff, nickel-matt / Kunststoff, weiss plastique, nickel mat / plastique, blanc	Ø 88, ET 40	Ø 75	3,7 W	 450 lm		1	901404	 9008606330836
	Ø 88, ET 40	Ø 75	3 x 3,7 W	 3 x 450 lm		3	901403	 9008606330829
 plastic, black / plastic, white Kunststoff, schwarz / Kunststoff, weiss plastique, noir / plastique, blanc	Ø 88, ET 40	Ø 75	3,7 W	 450 lm		1	901386	 9008606330676
	Ø 88, ET 40	Ø 75	3 x 3,7 W	 3 x 450 lm		3	901385	 9008606330669
	Ø 88, ET 40	Ø 75	3,7 W	 450 lm	  IP44	1	901412	 9008606330904





















































FUEVA 6

recessed light
Einbauleuchte
luminaire encastrable



Material / Colour	Size	Cutout	Watt		Lumen		IP class	Material-Nr.	EAN code
 plastic, white / plastic, white Kunststoff, weiss / Kunststoff, weiss plastique, blanc / plastique, blanc	Ø 119, ET 40	Ø 105	6,3 W		720 lm			901396	 9008606330768
	Ø 119, ET 40	Ø 105	6,3 W		720 lm		 IP44	901417	 9008606330942
	Ø 168, ET 40	Ø 155	10,5 W		1200 lm			901397	 9008606330775
	Ø 168, ET 40	Ø 155	10,5 W		1200 lm		 IP44	901418	 9008606330959
	Ø 216, ET 40	Ø 205	18,5 W		2100 lm			901398	 9008606330782
 plastic, satin nickel / plastic, white Kunststoff, nickel-matt / Kunststoff, weiss plastique, nickel mat / plastique, blanc	Ø 119, ET 40	Ø 105	6,3 W		720 lm			901405	 9008606330843
	Ø 168, ET 40	Ø 155	10,5 W		1200 lm			901406	 9008606330850
	Ø 216, ET 40	Ø 205	18,5 W		2100 lm			901407	 9008606330867
 plastic, black / plastic, white Kunststoff, schwarz / Kunststoff, weiss plastique, noir / plastique, blanc	Ø 119, ET 40	Ø 105	6,3 W		720 lm			901387	 9008606330683
	Ø 119, ET 40	Ø 105	6,3 W		720 lm		 IP44	901413	 9008606330911
	Ø 168, ET 40	Ø 155	10,5 W		1200 lm			901388	 9008606330690
	Ø 168, ET 40	Ø 155	10,5 W		1200 lm		 IP44	901414	 9008606330928
	Ø 216, ET 40	Ø 205	18,5 W		2100 lm			901389	 9008606330706



FUEVA FLEX

Flexible mounting bracket for various ceiling cut-outs from 68-100 mm.

Flexibler Einbaubügel für verschiedene Deckenausschnitte von 68-100 mm.





















Support de montage flexible pour différentes découpes de plafond de 68 à 100 mm.



FUEVA FLEX

recessed light
Einbauleuchte
luminaire encastrable





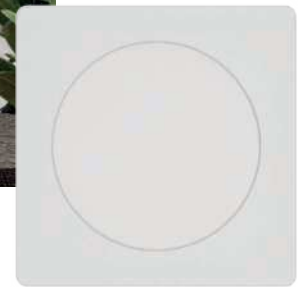
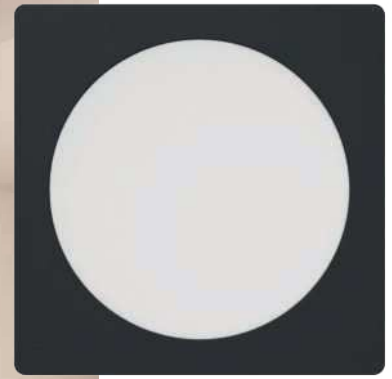



























Material / Colour	Size	Cutout	Watt		Lumen		Material-Nr.	EAN code
 aluminium, white / plastic, white Alu, weiss / Kunststoff, weiss aluminium, blanc / plastique, blanc	Ø 117, ET 20	Ø 68-100	5,5 W	 warm WHITE	650 lm		900932	 9008606277735
	Ø 117, ET 20	Ø 68-100	5,5 W	 neutral WHITE	700 lm		900935	 9008606277766
 aluminium, satin nickel / plastic, white Alu, nickel-matt / Kunststoff, weiss aluminium, nickel mat / plastique, blanc	Ø 117, ET 20	Ø 68-100	5,5 W	 warm WHITE	650 lm		900933	 9008606277742
	Ø 117, ET 20	Ø 68-100	5,5 W	 neutral WHITE	700 lm		900936	 9008606277773
 aluminium, black / plastic, white Alu, schwarz / Kunststoff, weiss aluminium, noir / plastique, blanc	Ø 117, ET 20	Ø 68-100	5,5 W	 warm WHITE	650 lm		900931	 9008606277728
	Ø 117, ET 20	Ø 68-100	5,5 W	 neutral WHITE	700 lm		900934	 9008606277759



FUEVA 6

recessed light
Einbauleuchte
luminaire encastrable



Material / Colour	Size	Cutout	Watt		Lumen		Material-Nr.	EAN code
 plastic, white / plastic, white Kunststoff, weiss / Kunststoff, weiss plastique, blanc / plastique, blanc	L 119, B 119, ET 40	Ø 105	6,3 W		720 lm		901399	 9008606330799
	L 166, B 166, ET 40	Ø 155	10,5 W		1200 lm		901401	 9008606330805
	L 216, B 216, ET 40	Ø 205	18,5 W		2100 lm		901402	 9008606330812
 plastic, satin nickel / plastic, white Kunststoff, nickel-matt / Kunststoff, weiss plastique, nickel mat / plastique, blanc	L 119, B 119, ET 40	Ø 105	6,3 W		720 lm		901408	 9008606330874
	L 166, B 166, ET 40	Ø 155	10,5 W		1200 lm		901409	 9008606330881
	L 216, B 216, ET 40	Ø 205	18,5 W		2100 lm		901411	 9008606330898
 plastic, black / plastic, white Kunststoff, schwarz / Kunststoff, weiss plastique, noir / plastique, blanc	L 119, B 119, ET 40	Ø 105	6,3 W		720 lm		901391	 9008606330713
	L 166, B 166, ET 40	Ø 155	10,5 W		1200 lm		901392	 9008606330720
	L 216, B 216, ET 40	Ø 205	18,5 W		2100 lm		901393	 9008606330737



FUEVA 5

recessed light
Einbauleuchte
luminaire encastrable



Material / Colour	Size	Cutout	Watt	Lumen	IP class	Material-Nr.	EAN code
steel, white / plastic, white Stahl, weiss / Kunststoff, weiss acier, blanc / plastique, blanc	Ø 117, ET 26	Ø 105	5,5 W	650 lm		99191	9002759991913
	Ø 166, ET 26	Ø 155	11 W	1350 lm		99192	9002759991920
	Ø 216, ET 26	Ø 205	17 W	2000 lm		99193	9002759991937
steel, chrome / plastic, white Stahl, chrom / Kunststoff, weiss acier, chrome / plastique, blanc	Ø 86, ET 26	Ø 75	2,7 W	330 lm	IP44	99204	9002759992040
	Ø 86, ET 26	Ø 75	2,7 W	330 lm	IP44	99208	9002759992088

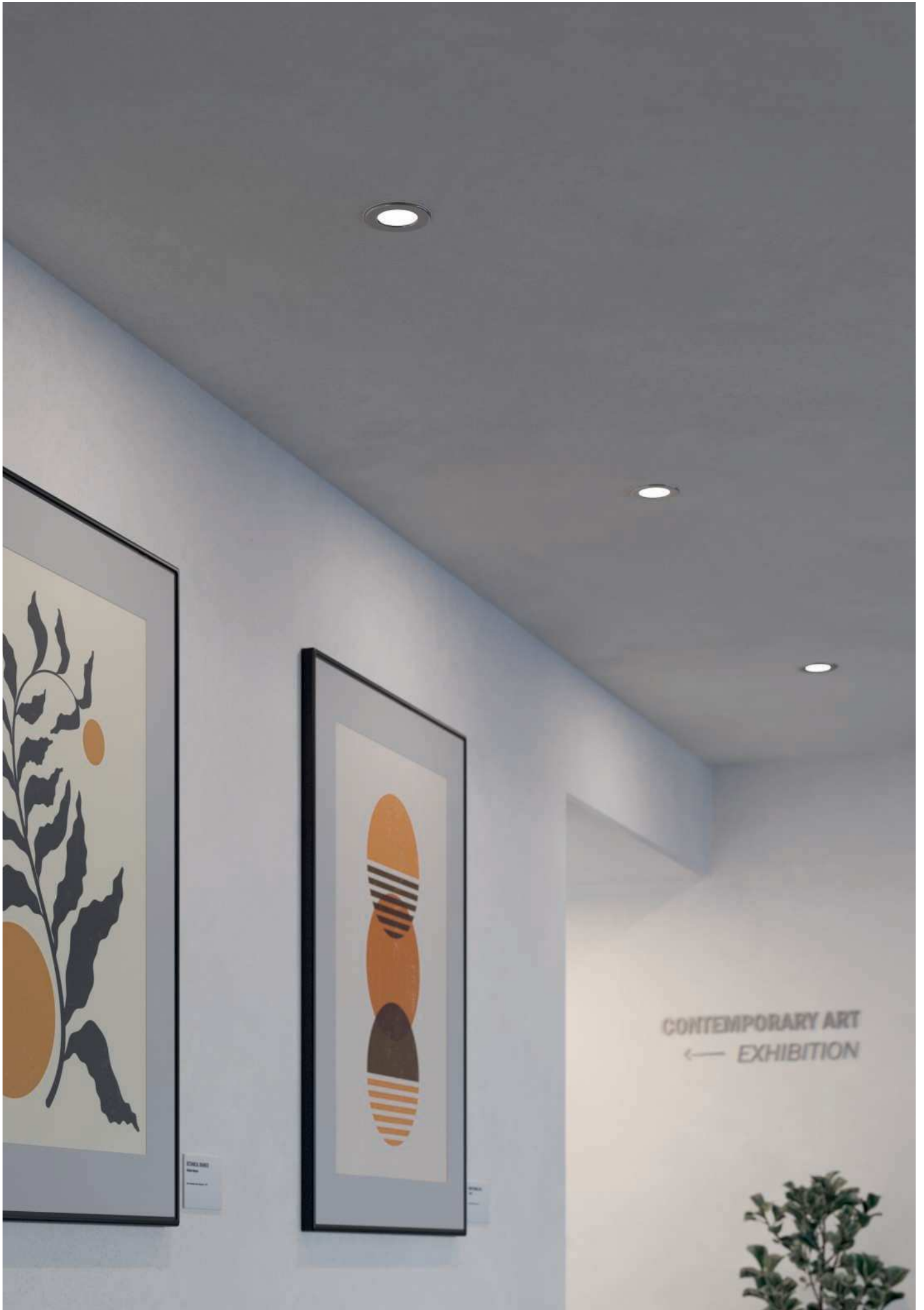

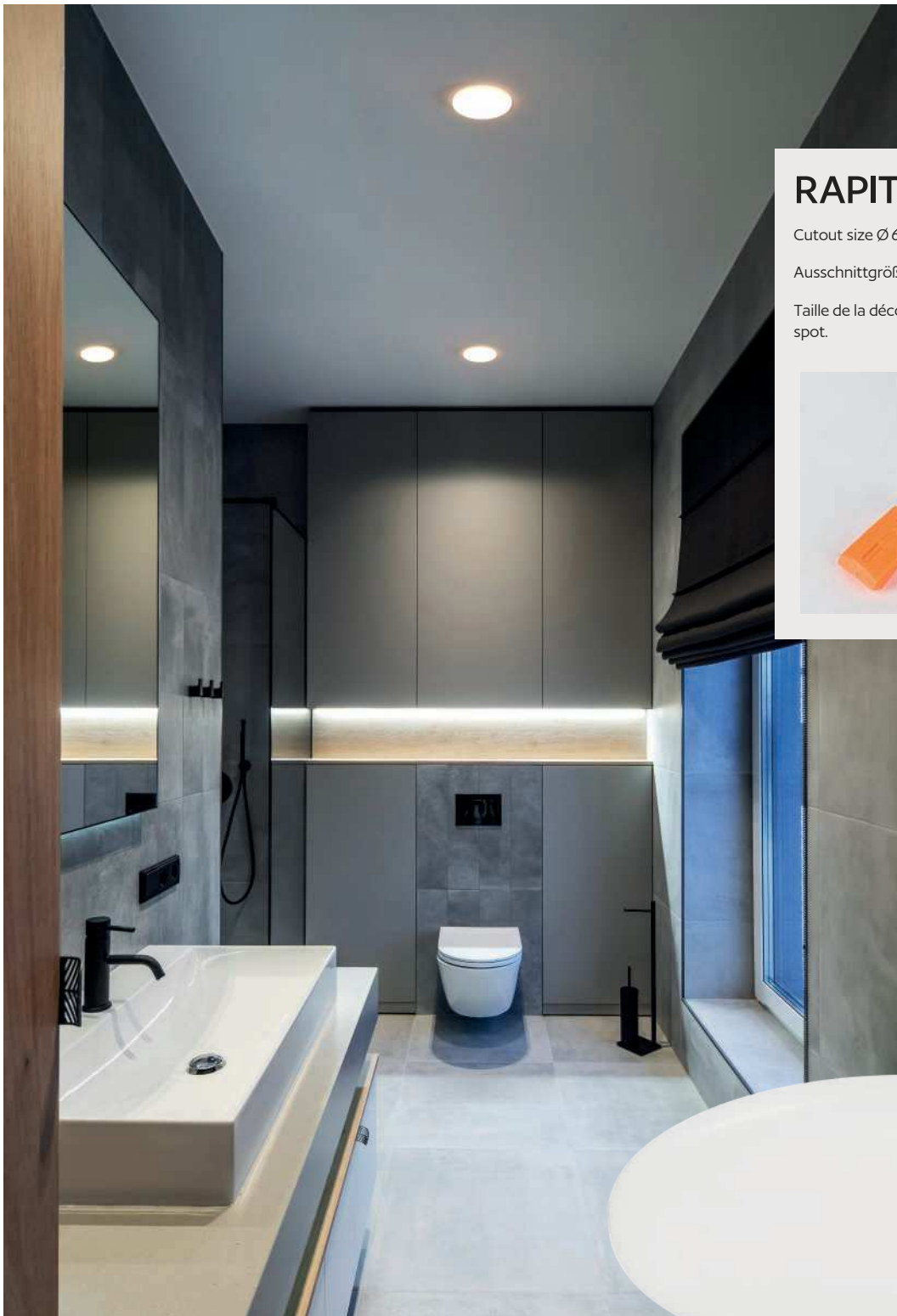

RAPITA

Cutout size Ø 68 mm for all spot sizes.

Ausschnittgröße Ø 68 mm für alle Spotgrößen.

Taille de la découpe Ø 68 mm pour toutes les tailles de spot.

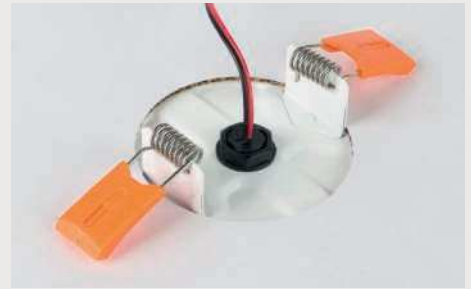

RAPITA

recessed light
Einbauleuchte
luminaire encastrable





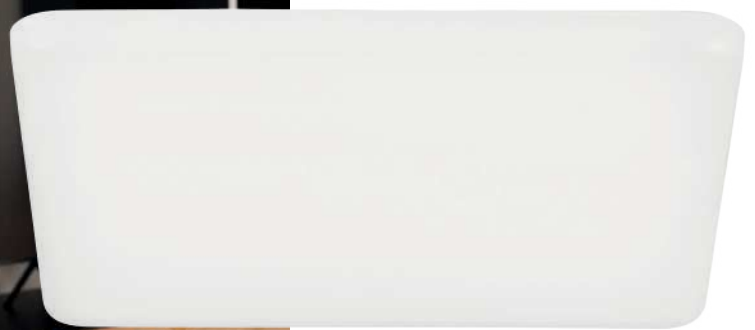













Material / Colour	Size	Cutout	Watt	Lumen	IP class	Material-Nr.	EAN code
aluminium, white / plastic, white Alu, weiss / Kunststoff, weiss aluminium, blanc / plastique, blanc	Ø 155, ET 30	Ø 68	11,5 W	1550 lm	IP20/65	900964	 9008606275106
	Ø 215, ET 30	Ø 68	18 W	2400 lm	IP20/65	900965	 9008606275113



RAPITA

recessed light
Einbauleuchte
luminaire encastrable

















Material / Colour	Size	Cutout	Watt	Lumen	IP class	Material-Nr.	EAN code
 aluminium, white / plastic, white Alu, weiss / Kunststoff, weiss aluminium, blanc / plastique, blanc	L 75, B 75, ET 30	Ø 68	4,5 W	 600 lm	  IP20/65	900966	 9008606275120
	L 100, B 100, ET 30	Ø 68	5,5 W	 750 lm	  IP20/65	900967	 9008606275137
	L 155, B 155, ET 30	Ø 68	11,5 W	 1550 lm	  IP20/65	900968	 9008606275144
	L 215, B 215, ET 30	Ø 68	18 W	 2400 lm	  IP20/65	900969	 9008606275151



PINEDA

recessed light
Einbauleuchte
luminaire encastrable



Material / Colour	Size	Cutout	Watt	Lumen	IP class	Quantity	Material-Nr.	EAN code
 plastic, white Kunststoff, weiss plastique, blanc	Ø 78, ET 35	Ø 65	3 x 4,9 W	 3 x 360 lm	  IP20/44	3	95821	 9002759958213
 plastic, satin nickel Kunststoff, nickel-matt plastique, nickel mat	Ø 78, ET 35	Ø 65	3 x 4,9 W	 3 x 360 lm	  IP20/44	3	95823	 9002759958237
 plastic, black Kunststoff, schwarz plastique, noir	Ø 78, ET 35	Ø 65	3 x 4,9 W	 3 x 360 lm	  IP20/44	3	900744	 9008606253715



PINEDA

These spot heads can be swivelled.

Diese Spot-Köpfe sind schwenkbar.













Ces têtes de spot sont orientables.



PINEDA

recessed light
Einbauleuchte
luminaire encastrable



Material / Colour	Size	Cutout	Watt	Lumen	Quantity	Material-Nr.	EAN code
 plastic, white Kunststoff, weiss plastique, blanc	Ø 84, ET 40	Ø 72	3 x 4,9 W	 3 x 360 lm	 3	95851	 9002759958510
 plastic, satin nickel Kunststoff, nickel-matt plastique, nickel mat	Ø 84, ET 40	Ø 72	3 x 4,9 W	 3 x 360 lm	 3	95853	 9002759958534
 plastic, black Kunststoff, schwarz plastique, noir	Ø 84, ET 40	Ø 72	3 x 5,5 W	 3 x 360 lm	 3	900749	 9008606253760

COMFORT

COMFORT

LE CONFORT

- Outstanding light output bright lighting : The Comfort series delivers an impressive light output that effectively illuminates even large rooms.
 - High-quality materials for durability: The high-quality metal housing not only ensures a modern, elegant design, but also excellent heat dissipation and durability.
 - Maximum functionality and flexibility.
 - Dimmable: Adjust the light intensity to suit your individual needs - from atmospheric ambience to full brightness.
 - Easy installation: The Comfort spotlights are quick and easy to install, even for less experienced.
-
- Übertroffene Lichtleistung, helle Beleuchtung : Die Comfort-Serie liefert eine beeindruckende Lichtleistung, die selbst große Räume effektiv ausleuchtet.
 - Hochwertige Materialien für Langlebigkeit: Das hochwertige Metallgehäuse sorgt nicht nur für ein modernes, edles Design, sondern auch für eine hervorragende Wärmeableitung und Langlebigkeit.
 - Maximale Funktionalität und Flexibilität.
 - Dimmbar: Passen Sie die Lichtintensität individuell an Ihre Bedürfnisse an – von stimmungsvollem Ambiente bis hin zu voller Helligkeit.
 - Einfache Installation: Die Comfort-Spots sind einfach und schnell zu montieren, auch für weniger erfahrene Heimwerker.
-
- Puissance lumineuse supérieure éclairage lumineux : La série Comfort fournit une puissance lumineuse impressionnante qui éclaire efficacement même les grandes pièces.
 - Des matériaux de qualité pour une longue durée de vie : le boîtier de haute qualité en métal assure non seulement un design moderne et élégant, mais aussi une excellente dissipation de la chaleur et une longue durée de vie.
 - Fonctionnalité et flexibilité maximales.
 - Réglable : adaptez l'intensité lumineuse à vos besoins individuels, de l'ambiance feutrée à la luminosité totale.
 - Installation facile Convivial : les spots Comfort sont faciles et rapides à installer, même pour les bricoleurs moins expérimentés.

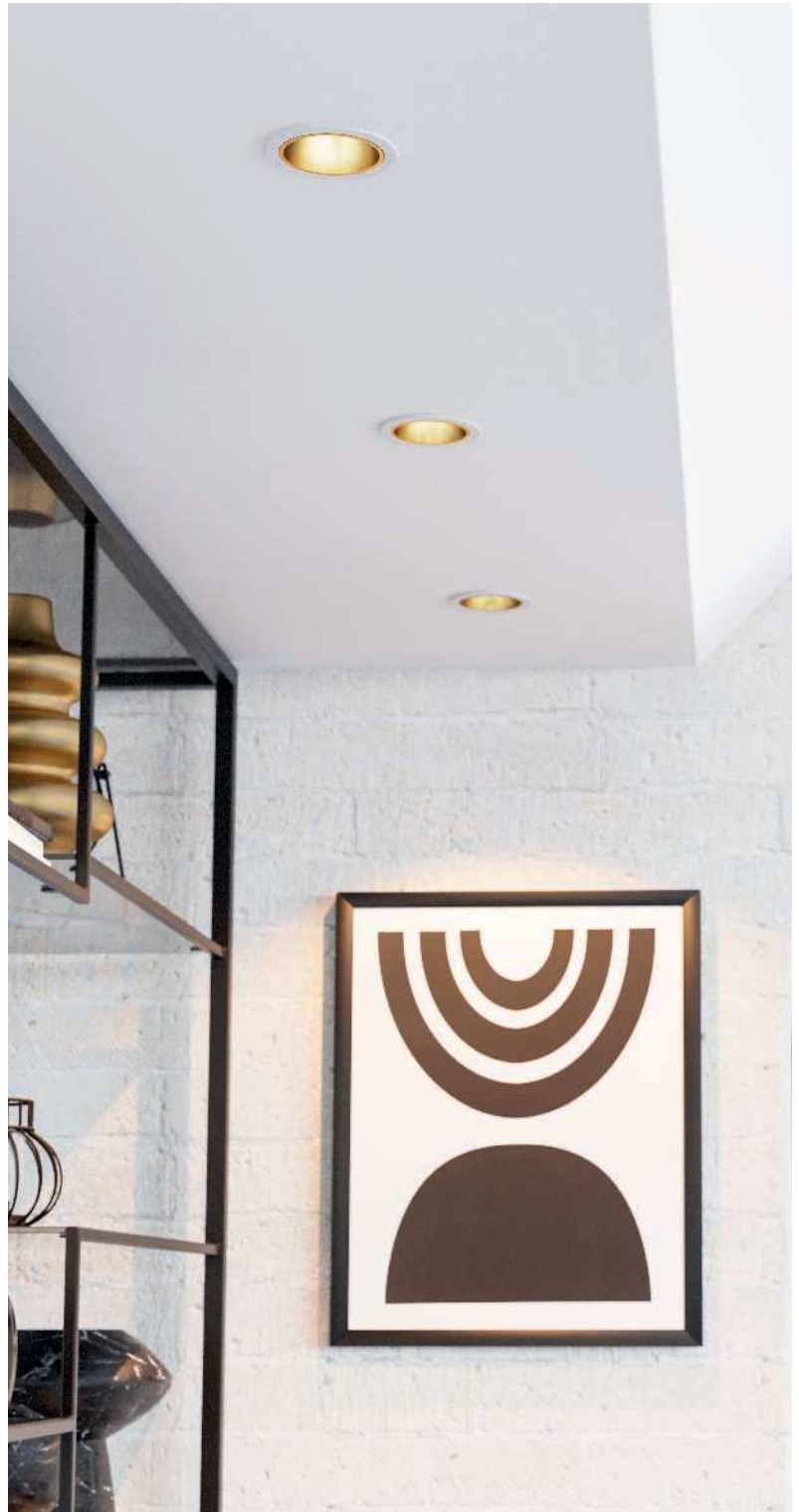

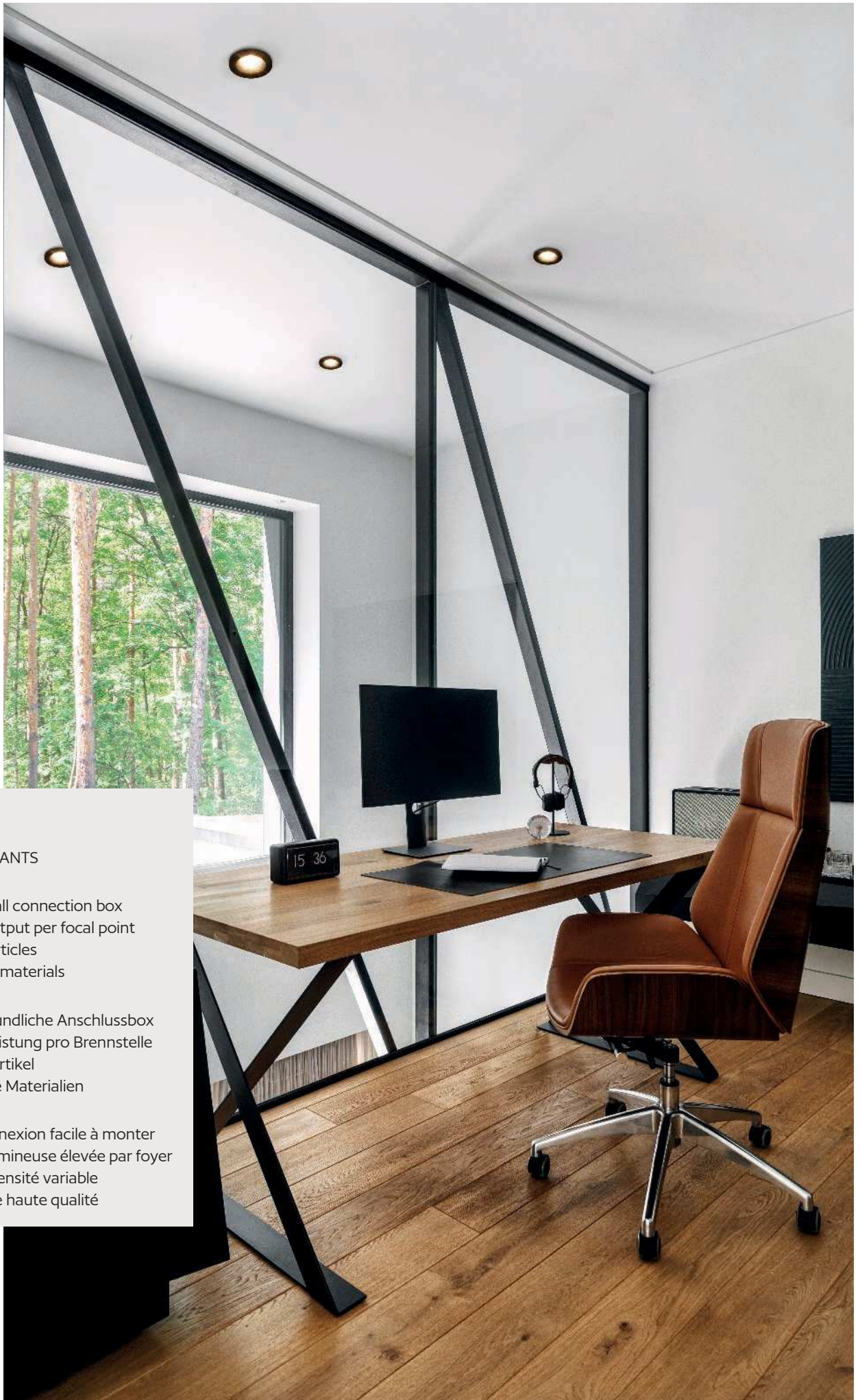

HIGHLIGHTS

HIGHLIGHTS

FAITS MARQUANTS

- Easy-to-install connection box
- High light output per focal point
- Dimmable articles
- High-quality materials

- Montagefreundliche Anschlussbox
- Hohe Lichtleistung pro Brennstelle
- Dimmbare Artikel
- Hochwertige Materialien

- Boîte de connexion facile à monter
- Puissance lumineuse élevée par foyer
- Articles à intensité variable
- Matériaux de haute qualité

SALICETO

Replaceable bulb, compatible with:

Leuchtmittel tauschbar, kompatibel mit:

Ampoule interchangeable, compatible avec :

- > PUCK CCT
- > PUCK CCT/DIM
- > PUCK COB WW
- > PUCK COB NW
- > PUCK SMART RGB+TW

Learn more on pages 8-9.

Mehr erfahren Sie auf den Seiten 8-9.

En savoir plus aux pages 8-9.



SALICETO

recessed light
Einbauleuchte
luminaire encastrable



Material / Colour	Size	Cutout	Watt	Lumen	Quantity	Material-Nr.	EAN code
aluminium, white Alu, weiss aluminium, blanc	Ø 88, ET 56	Ø 68	4,8 W	450 lm	1	98243	9002759982430
	Ø 88, ET 56	Ø 68	3 x 4,8 W	3 x 450 lm	3	902277	9008606358786
	Ø 88, ET 56	Ø 68	6,4 W	600 lm	1	902329	9008606358816
aluminium, satin nickel Alu, nickel-matt aluminium, nickel mat	Ø 88, ET 56	Ø 68	4,8 W	450 lm	1	98244	9002759982447
	Ø 88, ET 56	Ø 68	3 x 4,8 W	3 x 450 lm	3	902279	9008606358809
	Ø 88, ET 56	Ø 68	6,4 W	600 lm	1	902331	9008606358823
aluminium, black Alu, schwarz aluminium, noir	Ø 88, ET 56	Ø 68	4,8 W	450 lm	1	98607	9002759986070
	Ø 88, ET 56	Ø 68	6,4 W	600 lm	1	33996	9002759339968
	Ø 88, ET 56	Ø 68	3 x 4,8 W	3 x 450 lm	3	902278	9008606358793



SALICETO

These spot heads can be swivelled.

Diese Spot-Köpfe sind schwenkbar.







































Ces têtes de spot sont orientables.



SALICETO

recessed light
Einbauleuchte
luminaire encastrable



Material / Colour	Size	Cutout	Watt		Lumen	Quantity	Material-Nr.	EAN code
 aluminium, white Alu, weiss aluminium, blanc	Ø 88, ET 42	Ø 68	4,8 W	 warm WHITE	450 lm		1	98301  9002759983017
	Ø 88, ET 42	Ø 68	6,4 W	 neutral WHITE	600 lm		1	98305  9002759983055
	Ø 88, ET 42	Ø 68	3 x 6,4 W	 neutral WHITE	3 x 600 lm		3	33391  9002759333911
	Ø 88, ET 42	Ø 68	3 x 4,8 W	 warm WHITE	3 x 450 lm		3	900745  9008606253722
 aluminium, satin nickel Alu, nickel-matt aluminium, nickel mat	Ø 88, ET 42	Ø 68	4,8 W	 warm WHITE	450 lm		1	98303  9002759983031
	Ø 88, ET 42	Ø 68	6,4 W	 neutral WHITE	600 lm		1	98307  9002759983079
	Ø 88, ET 42	Ø 68	3 x 4,8 W	 warm WHITE	3 x 450 lm		3	900746  9008606253739
	Ø 88, ET 42	Ø 68	3 x 6,4 W	 neutral WHITE	3 x 600 lm		3	902282  9008606358922
 aluminium, black Alu, schwarz aluminium, noir	Ø 88, ET 42	Ø 68	4,8 W	 warm WHITE	450 lm		1	98609  9002759986094
	Ø 88, ET 42	Ø 68	6,4 W	 neutral WHITE	600 lm		1	33997  9002759339975
	Ø 88, ET 42	Ø 68	3 x 4,8 W	 warm WHITE	3 x 450 lm		3	900747  9008606253746
	Ø 88, ET 42	Ø 68	3 x 6,4 W	 neutral WHITE	3 x 600 lm		3	902281  9008606358915



SALICETO

Replaceable bulb, compatible with:

Leuchtmittel tauschbar, kompatibel mit:

Ampoule interchangeable, compatible avec :

- › PUCK CCT
- › PUCK CCT/DIM
- › PUCK COB WW
- › PUCK COB NW
- › PUCK SMART RGB+TW

Learn more on pages 8-9.

Mehr erfahren Sie auf den Seiten 8-9.

En savoir plus aux pages 8-9.



SALICETO

recessed light
Einbauleuchte
luminaire encastrable



Material / Colour	Size	Cutout	Watt		Lumen		Quantity	Material-Nr.	EAN code
aluminium, white Alu, weiss aluminium, blanc	L 88, B 88, ET 42	Ø 68	4,8 W	warm WHITE	450 lm		1	98302	9002759983024
	L 88, B 88, ET 42	Ø 68	6,4 W	neutral WHITE	600 lm		1	98306	9002759983062
	L 88, B 88, ET 42	Ø 68	3 x 4,8 W	warm WHITE	3 x 450 lm		3	902283	9008606358830
	L 88, B 88, ET 42	Ø 68	3 x 6,4 W	neutral WHITE	3 x 600 lm		3	902328	9008606358939
aluminium, satin nickel Alu, nickel-matt aluminium, nickel mat	L 88, B 88, ET 42	Ø 68	4,8 W	warm WHITE	450 lm		1	98304	9002759983048
aluminium, black Alu, schwarz aluminium, noir	L 88, B 88, ET 42	Ø 68	6,4 W	neutral WHITE	600 lm		1	33394	9002759333942
	L 88, B 88, ET 42	Ø 68	4,8 W	warm WHITE	450 lm		1	98611	9002759986117
	L 88, B 88, ET 42	Ø 68	3 x 4,8 W	warm WHITE	3 x 450 lm		3	902284	9008606358847
	L 88, B 88, ET 42	Ø 68	3 x 6,4 W	neutral WHITE	3 x 600 lm		3	902285	9008606358946

SALICETO

These spot heads can be swivelled.

Diese Spot-Köpfe sind schwenkbar.

Ces têtes de spot sont orientables.



SALABATE

Replaceable bulb, compatible with:

Leuchtmittel tauschbar, kompatibel mit:

Ampoule interchangeable, compatible avec :

- > PUCK CCT
- > PUCK CCT/DIM
- > PUCK COB WW
- > PUCK COB NW
- > PUCK SMART RGB+TW

Learn more on pages 8-9.

Mehr erfahren Sie auf den Seiten 8-9.









En savoir plus aux pages 8-9.



SALABATE

recessed light
Einbauleuchte
luminaire encastrable



Material / Colour	Size	Cutout	Watt	Lumen	IP class	Quantity	Material-Nr.	EAN code
 aluminium, white Alu, weiss aluminium, blanc	Ø 88, ET 46	Ø 68	5 W	540 lm	IP65	1	902271	 9008606358854
	Ø 88, ET 46	Ø 68	3 x 5 W	3 x 540 lm	IP65	3	902272	 9008606358885
 aluminium, satin nickel Alu, nickel-matt aluminium, nickel mat	Ø 88, ET 46	Ø 68	5 W	540 lm	IP65	1	902275	 9008606358878
	Ø 88, ET 46	Ø 68	3 x 5 W	3 x 540 lm	IP65	3	902276	 9008606358908
 aluminium, black Alu, schwarz aluminium, noir	Ø 88, ET 46	Ø 68	5 W	540 lm	IP65	1	902273	 9008606358861
	Ø 88, ET 46	Ø 68	3 x 5 W	3 x 540 lm	IP65	3	902274	 9008606358892

SALABATE

SALABATE Designed for bathroom zone 1 - driver separate from the circuit board. You can find more information on pages 4-5.

Designed für Badezimmer Zone 1 – Treiber getrennt von der Platine. Mehr Informationen finden Sie auf den Seiten 4-5.

Conçu pour la zone 1 de la salle de bains - pilote séparé du circuit imprimé. Vous trouverez plus d'informations aux pages 4-5.



SALABATE

recessed light
Einbauleuchte
luminaire encastrable



Material / Colour	Size	Cutout	Watt	Lumen	IP class	Material-Nr.	EAN code
aluminium, white / glass, clear Alu, weiss / Glas, klar aluminium, blanc / verre, transparent	Ø 88, ET 56	Ø 68	6 W	380 lm	IP20/44	98238	9002759982386
	Ø 88, ET 56	Ø 68	6 W	450 lm	IP20/44	98241	9002759982416
aluminium, black / glass, clear Alu, schwarz / Glas, klar aluminium, noir / verre, transparent	Ø 88, ET 56	Ø 68	6 W	380 lm	IP20/44	99493	9002759994938



DETAIL
YEBRA

INCL. / INKL. / INCLUS

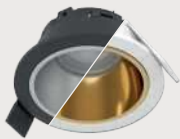

Interchangeable decorative rings in silver and gold included with the following items:

Auswechselbare Zierringe in Silber und Gold bei folgenden Artikeln im Lieferumfang enthalten:

Anneaux décoratifs interchangeables en argent et en or inclus dans la livraison des articles suivants :

902296, 902297



YEBRA

Replaceable bulb, compatible with:

Leuchtmittel tauschbar, kompatibel mit:

Ampoule interchangeable, compatible avec :

- › PUCK CCT
- › PUCK CCT/DIM
- › PUCK COB WW
- › PUCK COB NW
- › PUCK SMART RGB+TW

Learn more on pages 8-9.

Mehr erfahren Sie auf den Seiten 8-9.











En savoir plus aux pages 8-9.



YEBRA

recessed light
Einbauleuchte
luminaire encastrable



Material / Colour	Size	Cutout	Watt	Lumen	IP class	Material-Nr.	EAN code
 plastic, white Kunststoff, weiss plastique, blanc	Ø 87, ET 44	Ø 68	4,8 W	 480 lm	  IP44	902297	 9008606359028
 plastic, black Kunststoff, schwarz plastique, noir	Ø 87, ET 44	Ø 68	4,8 W	 480 lm	  IP44	902296	 9008606359011



DETAIL
CALONGE RGB

INCL. / INKL. / INCLUS



Included in the scope of delivery for the following items:

Bei folgenden Artikeln im Lieferumfang enthalten:









Les éléments suivants sont inclus dans la livraison :

901117, 901118

CALONGE RGB

recessed light
Einbauleuchte
luminaire encastrable



Material / Colour	Size	Cutout	Watt	Lumen	IP class	Quantity	Material-Nr.	EAN code
 plastic, white Kunststoff, weiss plastique, blanc	Ø 98, ET 32	Ø 75	3 x 3,8 W	 3 x 520 lm	 Remote	3	901117	 9008606297382
 plastic, black, white Kunststoff, schwarz, weiss plastique, noir, blanc	Ø 98, ET 32	Ø 75	3 x 3,8 W	 3 x 520 lm	 Remote	3	901118	 9008606297399

MENGIBAR TUBE

Easy upgrade for modern lighting: The flexible recessed spots of the MENGIBAR series combine contemporary design with maximum flexibility. Thanks to the dimmable function and adjustable light colour, the lighting can be individually adapted to any mood and room. With the optional adapter, the spots can also be mounted as a surface version, offering even more design freedom.

Einfaches Upgrade für moderne Beleuchtung: Die flexiblen Einbauspots der Serie MENGIBAR verbinden zeitgemäßes Design mit maximaler Flexibilität. Dank dimmbarer Funktion und einstellbarer Lichtfarbe lässt sich die Beleuchtung individuell an Stimmung und Raum anpassen. Mit optionalem Adapter können die Spots auch als Aufbauversion montiert werden, für noch mehr Gestaltungsfreiheit.

Mise à niveau facile pour un éclairage moderne : les spots encastrés flexibles de la série MENGIBAR allient design contemporain et flexibilité maximale. Grâce à la fonction de variation et à la couleur de lumière réglable, l'éclairage s'adapte individuellement à chaque ambiance et à chaque pièce. Avec l'adaptateur en option, les spots peuvent également être montés en version apparente pour encore plus de liberté de conception.

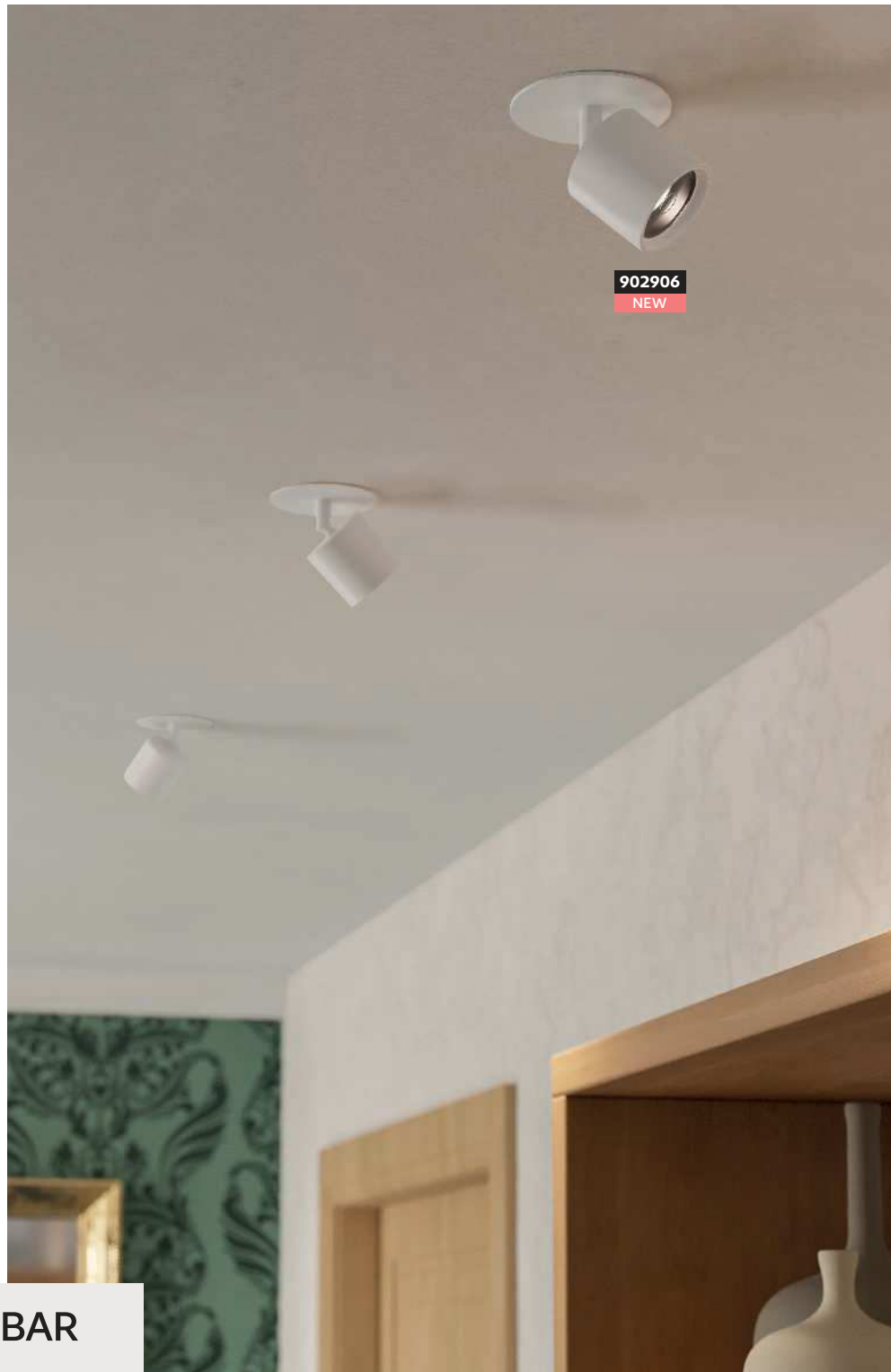

902906
NEW

MENGIBAR TUBE

These luminaires have a CCT switch in the canopy to control the colour temperature.

Diese Leuchten verfügen über einen CCT-Schalter im Baldachin zur Steuerung der Farbtemperatur.

Ces luminaires disposent d'un interrupteur CCT dans le baldachin pour contrôler la température de couleur.



MENGIBAR TUBE

The heads of this luminaire can be swiveled individually.

Die Leuchtenköpfe sind individuell schwenkbar.

Les têtes de ce luminaire peuvent être pivotées individuellement.



902906 MENGIBAR TUBE

spot; plastic, white matt
Spot; Kunststoff, weiss matt
spot; plastique, blanc mat

H 108, Ø 90, ET 25



1 x
4,8 W



1 x
450 lm



Ø 68



9008606399475



902721
NEW



902723
NEW



902722
NEW

902721 MENGIBAR TUBE

spot; plastic, black
Spot; Kunststoff, schwarz
spot; plastique, noir

902723 MENGIBAR TUBE

spot; plastic, bronze, black
Spot; Kunststoff, bronze, schwarz
spot; plastique, bronze, noir

902722 MENGIBAR TUBE

spot; plastic, gold, black
Spot; Kunststoff, gold, schwarz
spot; plastique, or, noir

↕ H 108, Ø 90, ET 35

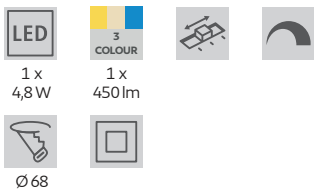

↕ H 108, Ø 90, ET 25

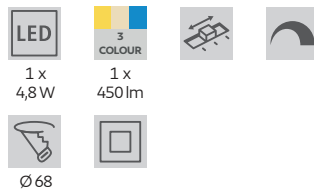

↕ H 108, Ø 90, ET 25

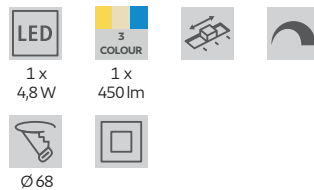

MENGIBAR TUBE

Easy upgrade for modern lighting: The flexible recessed spots of the MENGIBAR series combine contemporary design with maximum flexibility. Thanks to the dimmable function and adjustable light colour, the lighting can be individually adapted to any mood and room. With the optional adapter, the spots can also be mounted as a surface version, offering even more design freedom.

Einfaches Upgrade für moderne Beleuchtung: Die flexiblen Einbauspots der Serie MENGIBAR verbinden zeitgemäßes Design mit maximaler Flexibilität. Dank dimmbarer Funktion und einstellbarer Lichtfarbe lässt sich die Beleuchtung individuell an Stimmung und Raum anpassen. Mit optionalem Adapter können die Spots auch als Aufbaulösung montiert werden, für noch mehr Gestaltungsfreiheit.

Mise à niveau facile pour un éclairage moderne : les spots encastrés flexibles de la série MENGIBAR allient design contemporain et flexibilité maximale. Grâce à la fonction de variation et à la couleur de lumière réglable, l'éclairage s'adapte individuellement à chaque ambiance et à chaque pièce. Avec l'adaptateur en option, les spots peuvent également être montés en version apparente pour encore plus de liberté de conception.



902725
NEW

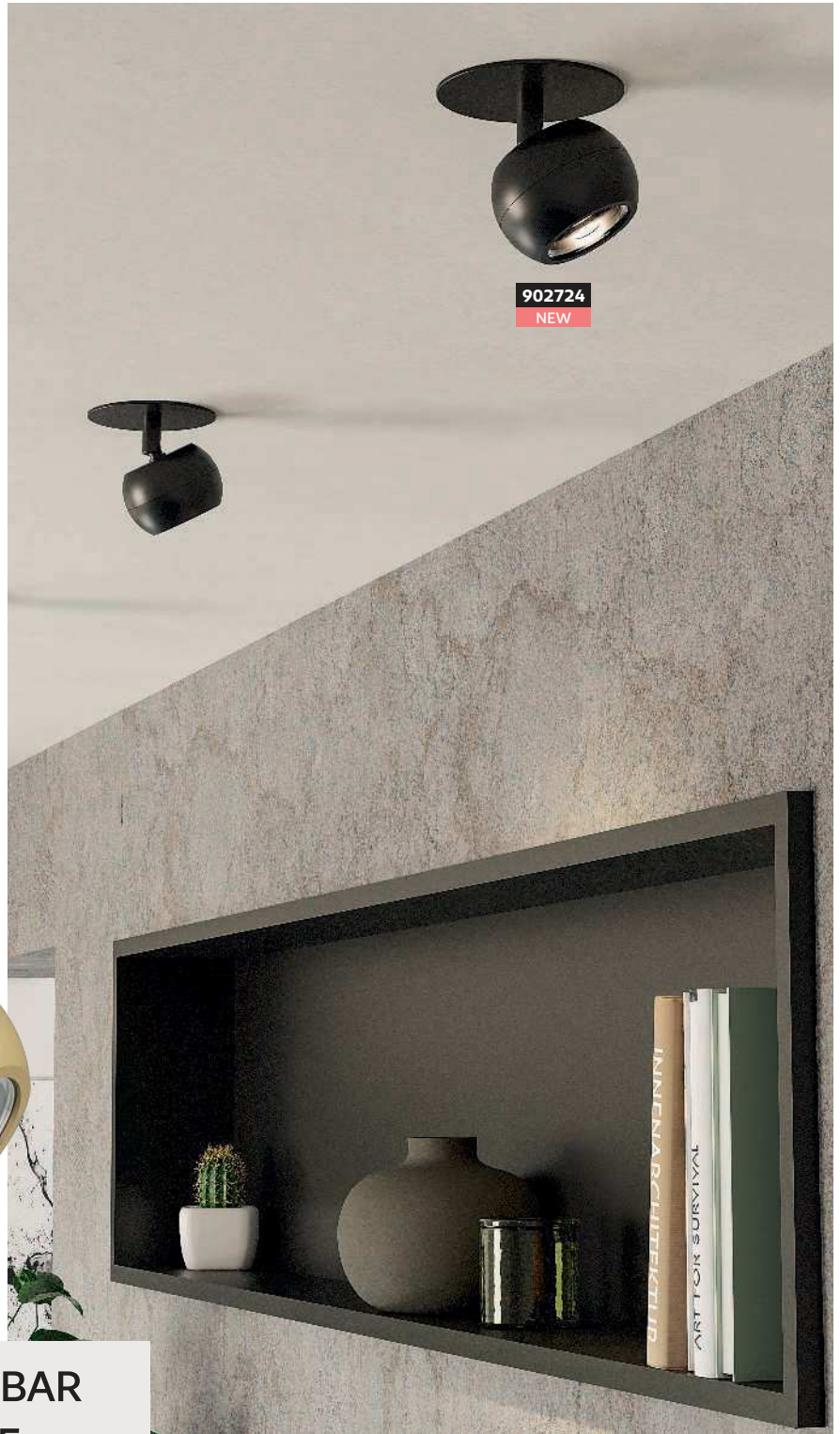

902724
NEW

MENGIBAR SPHERE

These luminaires have a CCT switch in the canopy to control the colour temperature.

Diese Leuchten verfügen über einen CCT-Schalter im Baldachin zur Steuerung der Farbtemperatur.

Ces luminaires disposent d'un interrupteur CCT dans le baldachin pour contrôler la température de couleur.



MENGIBAR SPHERE

The heads of this luminaire can be swiveled individually.

Die Leuchtenköpfe sind individuell schwenkbar.

Les têtes de ce luminaire peuvent être pivotées individuellement.

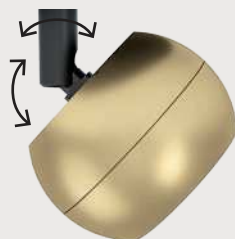

902725 MENGIBAR SPHERE

spot; plastic, gold, black
Spot; Kunststoff, gold, schwarz
spot; plastique, or, noir

⤴ H 98, Ø 90, ET 25



1 x
4,8 W



1 x
450 lm



Ø 68



9008606392926

902724 MENGIBAR SPHERE

spot; plastic, black
Spot; Kunststoff, schwarz
spot; plastique, noir

⤴ H 98, Ø 90, ET 25



1 x
4,8 W



1 x
450 lm



Ø 68



9008606392919

MENGIBAR MOUNTING

These accessories enable all MENGIBAR SPHERE and MENGIBAR TUBE items to also be used as surface-mounted luminaires.

Diese Zubehörartikel ermöglichen es, alle MENGIBAR SPHERE und MENGIBAR TUBE Artikel auch als Aufbauleuchten zu verwenden.

Ces accessoires permettent d'utiliser tous les articles MENGIBAR SPHERE et MENGIBAR TUBE également comme luminaires apparents.



902726
NEW



902727
NEW

902726 MENGIBAR SPHERE

spot; plastic, bronze, black
Spot; Kunststoff, bronze, schwarz
spot; plastique, bronze, noir

↕ H 98, Ø 90, ET 25

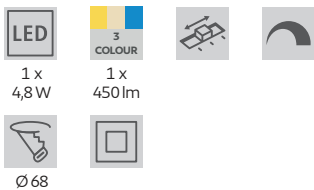

9008606392933

902727 MENGIBAR MOUNTING

accessory; plastic, black
Zubehör; Kunststoff, schwarz
Accessoires; plastique, noir

↕ H 25, Ø 70



9008606392940

902905 MENGIBAR MOUNTING

accessory; plastic, white matt
Zubehör; Kunststoff, weiss matt
Accessoires; plastique, blanc mat

↕ H 25, Ø 70



9008606399499

902907 MENGIBAR SPHERE

spot; plastic, white matt
Spot; Kunststoff, weiss matt
spot; plastique, blanc mat

↕ H 98, Ø 90, ET 25

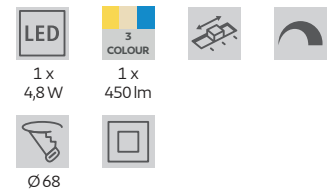

9008606399482

902905
NEW

902907
NEW

PREMIUM

PREMIUM PRIME

- Smart functions for modern requirements: Complete control via smartphone and remote control.
 - Versatile lighting effects and functions.
 - RGB colour spectrum: Transform your rooms with a wide range of colours - perfect for atmospheric lighting or special occasions.
 - High-quality materials for durability. The high-quality metal housing not only ensures a modern, elegant design, but also excellent heat dissipation and durability.
- Smarte Funktionen für moderne Ansprüche: Komplette Steuerung per Smartphone und Fernbedienung.
 - Vielseitige Lichteffekte und Funktionen.
 - RGB-Farbspektrum: Verwandeln Sie Ihre Räume mit einer breiten Auswahl an Farben – perfekt für stimmungsvolle Beleuchtung oder besondere Anlässe.
 - Hochwertige Materialien für Langlebigkeit: Das hochwertige Metallgehäuse sorgt nicht nur für ein modernes, edles Design, sondern auch für eine hervorragende Wärmeableitung und Langlebigkeit.
- Des fonctions intelligentes pour des exigences modernes : contrôle complet par smartphone et télécommande.
 - Effets lumineux et fonctions polyvalents.
 - Spectre de couleurs RGB : transformez vos pièces avec un large choix de couleurs - parfait pour un éclairage d'ambiance ou des occasions spéciales.
 - Des matériaux de qualité pour une longue durée de vie : le boîtier en métal de haute qualité assure non seulement un design moderne et élégant, mais aussi une excellente dissipation de la chaleur et une longue durée de vie.



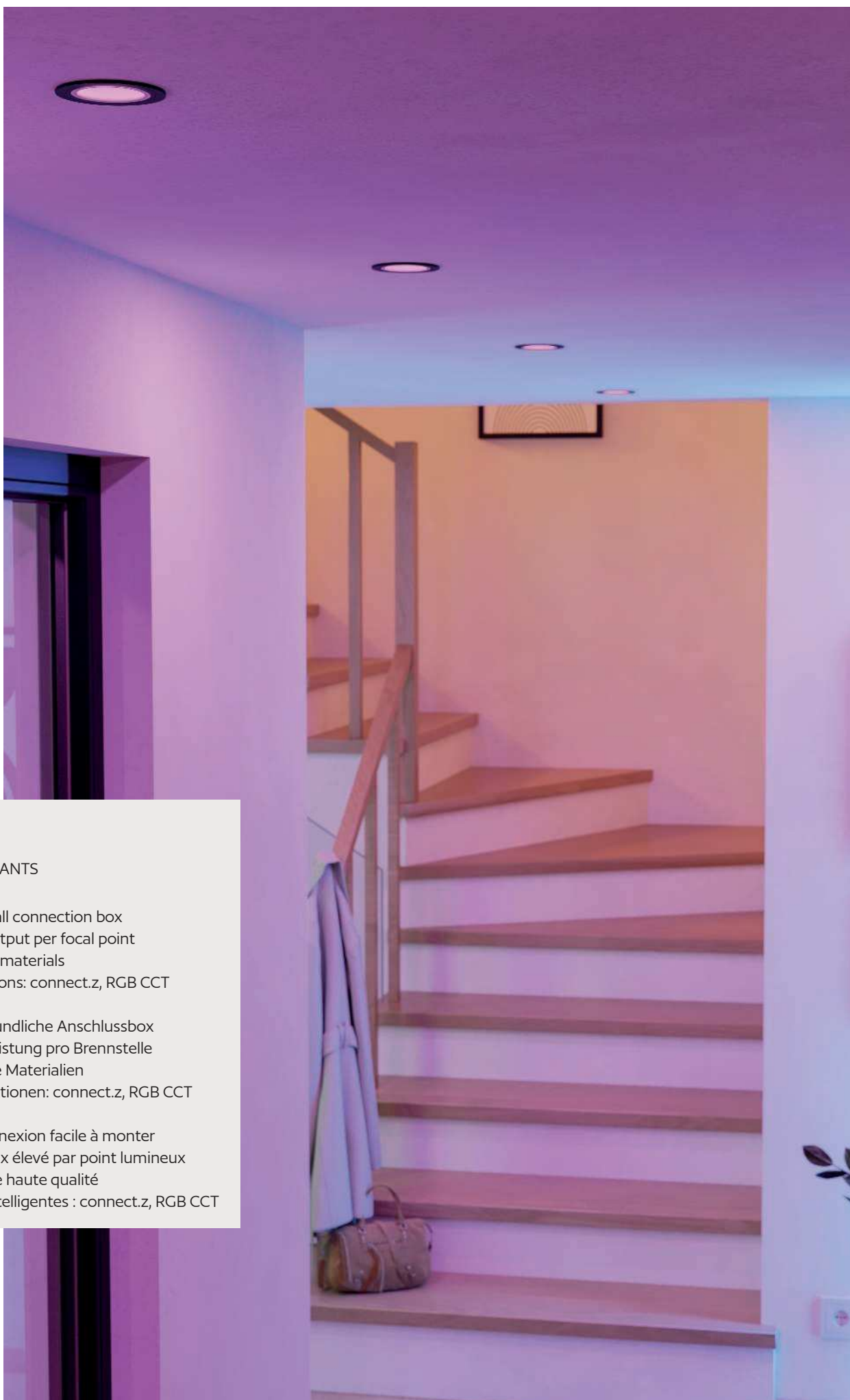

HIGHLIGHTS

HIGHLIGHTS

FAITS MARQUANTS



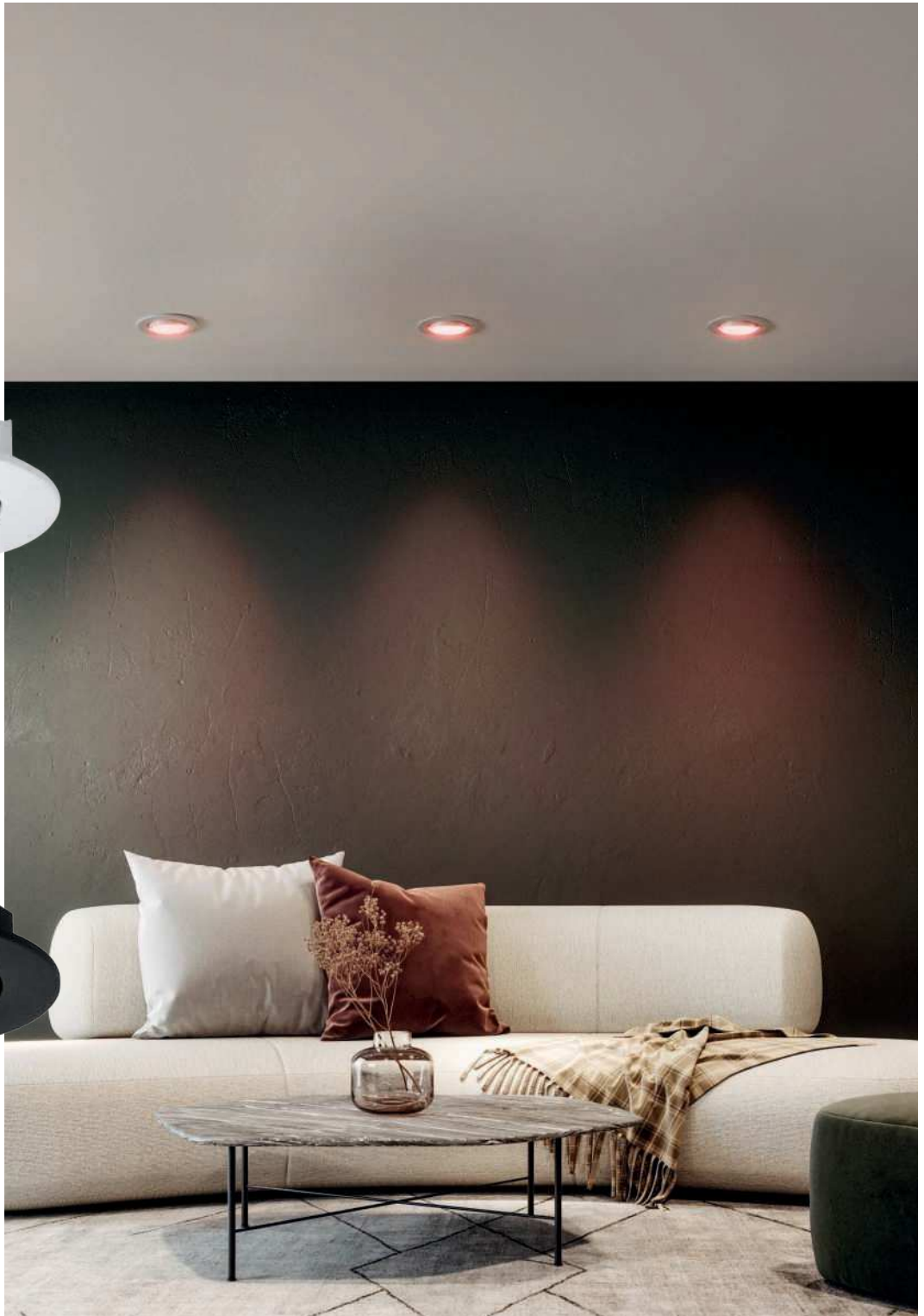











- Easy-to-install connection box
- High light output per focal point
- High-quality materials
- Smart functions: connect.z, RGB CCT
- Montagefreundliche Anschlussbox
- Hohe Lichtleistung pro Brennstelle
- Hochwertige Materialien
- Smarte Funktionen: connect.z, RGB CCT
- Boîte de connexion facile à monter
- Flux lumineux élevé par point lumineux
- Matériaux de haute qualité
- Fonctions intelligentes : connect.z, RGB CCT



SALICETO-Z

recessed light
Einbauleuchte
luminaire encastrable



Material / Colour	Size	Cutout	Watt	Lumen	Quantity	Material-Nr.	EAN code
 aluminium, white Alu, weiss aluminium, blanc	Ø 88, ET 42	Ø 68	4,7 W	 440 lm	 Remote, App 1	99671	 9002759996710
	Ø 88, ET 42	Ø 68	3 x 4,7 W	 3 x 1320 lm	 Remote, App 3	902286	 9008606358953
 aluminium, black Alu, schwarz aluminium, noir	Ø 88, ET 42	Ø 68	4,7 W	 440 lm	 Remote, App 1	99669	 9002759996697
	Ø 88, ET 42	Ø 68	3 x 4,7 W	 3 x 1320 lm	 Remote, App 3	902287	 9008606358960

YEBRA-Z

YEBRA-Z luminaires feature a recessed light source and an integrated honeycomb grid for particularly glare-free light beams. The smart LED PUCK modules allow for a shallow installation depth – making them ideal for renovations as well. With a standard cut-out of 68 mm, the spots are perfect for retrofitting. Available in white with a gold trim ring or in black with a silver trim ring. The included honeycomb grid can be easily removed if required.

YEBRA-Z Leuchten punkten mit zurückversetzter Lichtquelle und integriertem Wabengitter für besonders blendfreie Lichtkegel. Die smarten LED PUCK Module ermöglichen eine geringe Einbautiefe – ideal auch für Renovierungen. Mit einem Standard-Ausschnitt von 68 mm eignen sich die Spots perfekt zum Nachrüsten. Erhältlich in Weiß mit goldenem Zierring oder in Schwarz mit silbernem Zierring. Das inkludierte Wabengitter kann bei Bedarf einfach entfernt werden.

Les luminaires YEBRA-Z se distinguent par une source lumineuse en retrait et une grille alvéolée intégrée, offrant des faisceaux lumineux particulièrement peu éblouissants. Les modules LED PUCK intelligents permettent une faible profondeur d'encastrement – idéale également pour les rénovations. Avec une découpe standard de 68 mm, ces spots sont parfaits pour la modernisation ou le remplacement. Disponibles en blanc avec un anneau décoratif doré ou en noir avec un anneau décoratif argenté. La grille alvéolée incluse peut être facilement retirée si nécessaire.

YEBRA-Z

Replaceable bulb, compatible with:

Leuchtmittel tauschbar, kompatibel mit:

Ampoule interchangeable, compatible avec :

- > PUCK CCT
- > PUCK CCT/DIM
- > PUCK COB WW
- > PUCK COB NW
- > PUCK SMART RGB+TW

Learn more on pages 8-9.

Mehr erfahren Sie auf den Seiten 8-9.



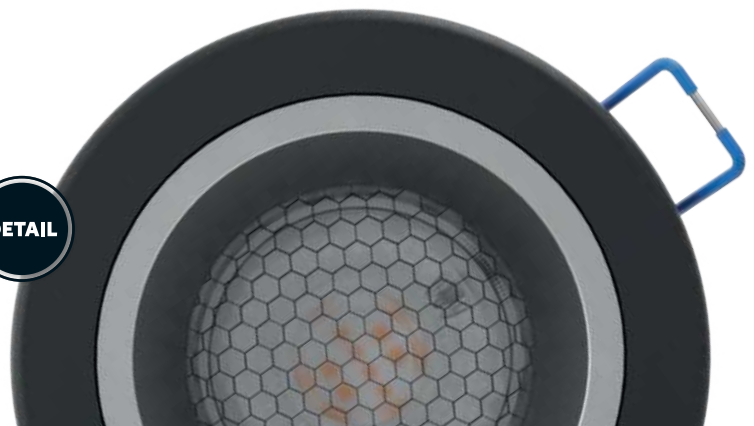





En savoir plus aux pages 8-9.



YEBRA-Z

recessed light
Einbauleuchte
luminaire encastrable



Material / Colour	Size	Cutout	Watt	Lumen	Material-Nr.	EAN code
 plastic, white, gold Kunststoff, weiss, gold plastique, blanc, or	Ø 87, ET 61	Ø 68	4,9 W	 490 lm	 Remote, App 902299	 9008606359042
 plastic, black, silver Kunststoff, schwarz, silber plastique, noir, argent	Ø 87, ET 61	Ø 68	4,9 W	 490 lm	 Remote, App 902298	 9008606359035



901168



CAROSSO-Z

Replaceable bulb, compatible with:

Leuchtmittel tauschbar, kompatibel mit:

Ampoule interchangeable, compatible avec :

- > PUCK CCT
- > PUCK CCT/DIM
- > PUCK COB WW
- > PUCK COB NW
- > PUCK SMART RGB+TW

Learn more on pages 8-9.

Mehr erfahren Sie auf den Seiten 8-9.

En savoir plus aux pages 8-9.



901169

CAROSSO-Z

The unique selling point of these products is its slightly recessed light source, which reduces glare from the side while the acrylic ring creates a distinctive lighting effect, enhancing the design stylishly.

Das besondere Merkmal dieser Produkte ist das leicht zurückgesetzte Leuchtmittel, das seitliche Blendung reduziert. Gleichzeitig sorgt der Acrylring für einen einzigartigen Lichteffect, der das Design stilvoll unterstreicht.

L'atout principal de ces produits est sa source lumineuse légèrement en retrait, ce qui réduit l'éblouissement latéral. Dans le même temps, l'anneau en acrylique crée un effet lumineux distinctif qui sublime le design avec élégance.



901168 CAROSSO-Z

surface-mounted light; aluminium, black / plastic, white

Aufbauleuchte; Alu, schwarz / Kunststoff, weiss

luminaire en saillie; aluminium, noir / plastique, blanc

H 120, Ø 80



GU10



1 x
4,9 W



1 x
345 lm



Remote,
App



9008606312900



901169 CAROSSO-Z

surface-mounted light; aluminium, white / plastic, white

Aufbauleuchte; Alu, weiss / Kunststoff, weiss

luminaire en saillie; aluminium, blanc / plastique, blanc

H 120, Ø 80



GU10



1 x
4,9 W



1 x
345 lm



Remote,
App



9008606312917





900764



900766



900763



900765



900764 CAROSSO-Z

recessed light; aluminium, black / plastic, white

Einbauleuchte; Alu, schwarz / Kunststoff, weiss

luminaire encastrable; aluminium, noir / plastique, blanc

∩ Ø 93, ET 70

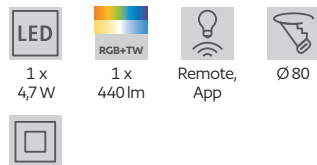

9008606259809

900766 CAROSSO-Z

recessed light; aluminium, white / plastic, white

Einbauleuchte; Alu, weiss / Kunststoff, weiss

luminaire encastrable; aluminium, blanc / plastique, blanc

∩ Ø 93, ET 70

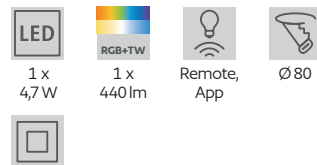

9008606259823

900763 CAROSSO-Z

recessed light; aluminium, black / plastic, white

Einbauleuchte; Alu, schwarz / Kunststoff, weiss

luminaire encastrable; aluminium, noir / plastique, blanc

∩ L 93, B 93, ET 70

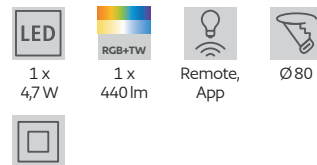

9008606259793

900765 CAROSSO-Z

recessed light; aluminium, white / plastic, white

Einbauleuchte; Alu, weiss / Kunststoff, weiss

luminaire encastrable; aluminium, blanc / plastique, blanc

∩ L 93, B 93, ET 70

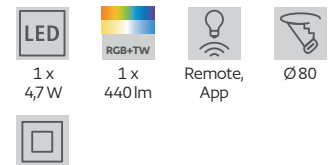

9008606259816

FUEVA 6-Z

For bright light while working or atmospheric lighting with dimmable RGB CCT effects – ideal for DIY projects with suspended ceilings. Thanks to its ultra-slim installation depth, it is perfect for retrofitting existing recessed spotlights with a 75 mm cutout, up to larger, high-performance models. The luminaires are available in white, matt black and satin nickel - also ideal for ceiling mounting in the bathroom thanks to IP44.

Für helles Licht beim Arbeiten oder stimmungsvolle Beleuchtung mit dimmbaren RGB CCT-Effekten – ideal für DIY-Projekte mit abgehängten Decken. Dank der besonders flachen Einbautiefe perfekt zur Nachrüstung bestehender Einbauspotlights mit 75 mm Ausschnitt bis hin zu größeren, leistungsstarken Modellen. Die Leuchten sind erhältlich in Weiß, Schwarz und Nickel matt – dank IP44 auch ideal für die Deckenmontage im Badezimmer geeignet.



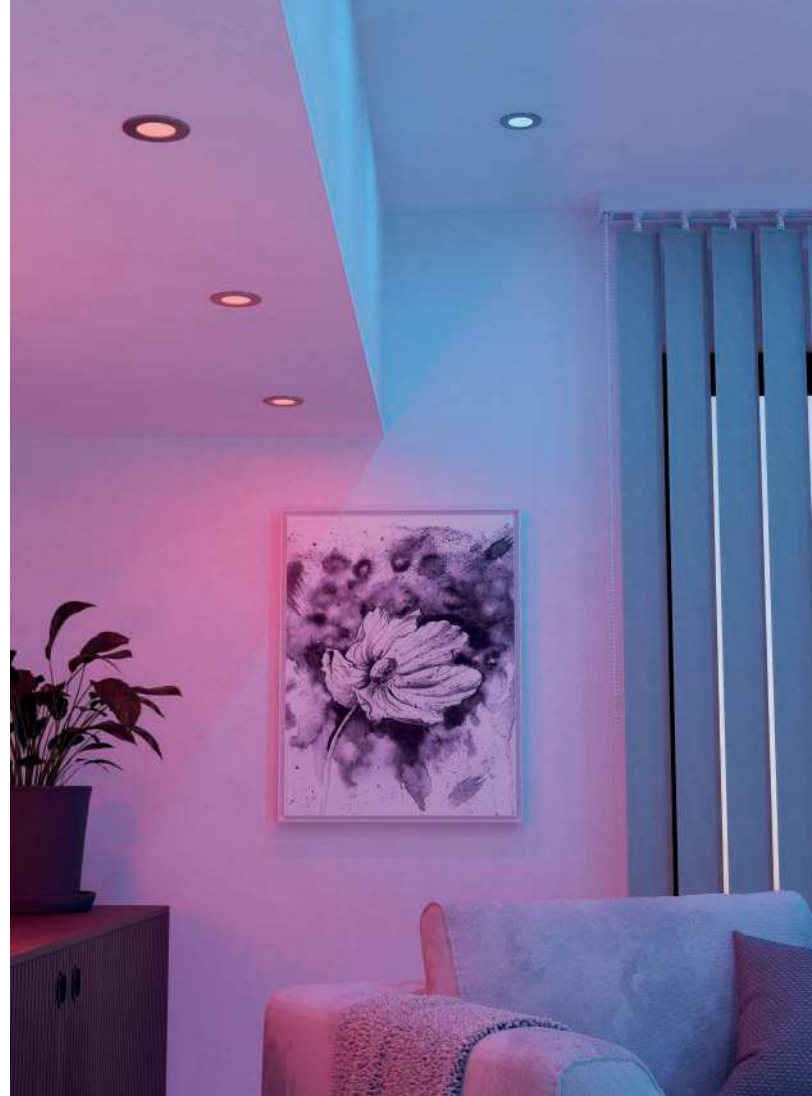



Pour une lumière vive lors du travail ou un éclairage d'ambiance avec des effets RGB CCT dimmables – idéal pour les projets DIY avec des plafonds suspendus. Grâce à sa profondeur d'encastrement ultra-mince, il est parfait pour moderniser des spots encastrés existants avec une découpe de 75 mm, jusqu'à des modèles plus grands et performants. Les luminaires sont disponibles en blanc, noir et nickel mat - grâce à l'IP44, ils sont également idéaux pour une installation au plafond dans la salle de bain.



FUEVA 6-Z

recessed light
Einbauleuchte
luminaire encastrable



Material / Colour	Size	Cutout	Watt	Lumen	IP class	Quantity	Material-Nr.	EAN code
 plastic, white / plastic, white Kunststoff, weiss / Kunststoff, weiss plastique, blanc / plastique, blanc	Ø 88, ET 40	Ø 75	3 x 2,8 W	 3 x 340 lm	 Remote, App	 IP44	3	901429  9008606330997
	Ø 120, ET 40	Ø 105	5 W	 620 lm	 Remote, App	 IP44	1	901431  9008606331000
	Ø 168, ET 40	Ø 155	9,5 W	 1150 lm	 Remote, App	 IP44	1	901432  9008606331017
 plastic, satin nickel / plastic, white Kunststoff, nickel-matt / Kunststoff, weiss plastique, nickel mat / plas- tique, blanc	Ø 88, ET 40	Ø 75	3 x 2,8 W	 3 x 340 lm	 Remote, App	 IP44	3	901434  9008606331024
	Ø 120, ET 40	Ø 105	5 W	 620 lm	 Remote, App	 IP44	1	901435  9008606331031
	Ø 168, ET 40	Ø 155	9,5 W	 1150 lm	 Remote, App	 IP44	1	901436  9008606331048
 plastic, black / plastic, white Kunststoff, schwarz / Kunststoff, weiss plastique, noir / plastique, blanc	Ø 88, ET 40	Ø 75	3 x 2,8 W	 3 x 340 lm	 Remote, App	 IP44	3	901425  9008606330966
	Ø 120, ET 40	Ø 105	5 W	 620 lm	 Remote, App	 IP44	1	901426  9008606330973
	Ø 168, ET 40	Ø 155	9,5 W	 1150 lm	 Remote, App	 IP44	1	901427  9008606330980

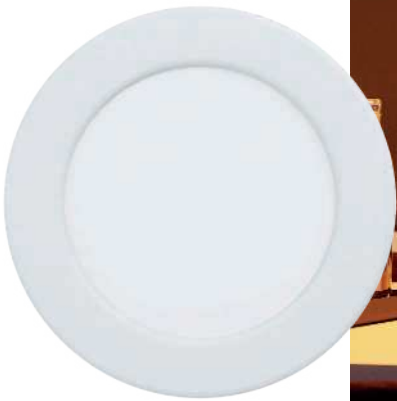



96901



900251

INCL. / INKL. / INCLUS

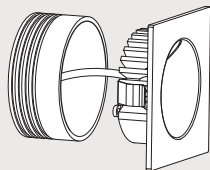

The plaster ring is included in the scope of delivery for the following items:

Bei folgenden Artikeln ist der Einputzring im Lieferumfang enthalten:

Pour les articles suivants, la bague à encastrier est incluse dans la livraison:

96901, 99643, 99644, 900251

96901 ZARATE

recessed light; cast aluminium, white / plastic, white

Einbauleuchte; Aluguss, weiss / Kunststoff, weiss

luminaire encastrable; fonte d'aluminium, blanc / plastique, blanc

↳ L 80, B 80, ET 40



1 x
2 W



1 x
90 lm



Ø63

900251 ZARATE

recessed light; cast aluminium, black / plastic, white

Einbauleuchte; Aluguss, schwarz / Kunststoff, weiss

luminaire encastrable; fonte d'aluminium, noir / plastique, blanc

↳ L 80, B 80, ET 40



1 x
2 W



1 x
90 lm



Ø63



9002759969011



9008606285778



99644

99643

99644 MECINOS

recessed light; steel, black
 Einbauleuchte; Stahl, schwarz
 luminaire encastrable; acier, noir

99643 MECINOS

recessed light; steel, white
 Einbauleuchte; Stahl, weiss
 luminaire encastrable; acier, blanc

↕ L 80, B 80, ET 50

			
1 x 2W	1 x 90lm		Ø 65

↕ L 80, B 80, ET 50

			
1 x 2W	1 x 90lm		Ø 68



9002759996444



9002759996437

RECESSED DOWNLIGHTS WITH SOCKET

EINBAULEUCHTEN MIT SOCKEL

LUMINAIRES ENCASTRÉS AVEC DOUILLE

Advantages

- Proven technology, customized solutions in every price category
- Depending on the selected illuminants appropriate for illuminating areas and rooms or for accent lighting
- Great colors and shapes
- Up to 80 % power savings compared to incandescent lamps, easy on your budget and the environment
- Illuminants replaceable

Vorteile

- Bewährte Technologie, individuelle Lösungen in jeder Preisklasse
- Je nach eingesetztem Leuchtmittel zur Beleuchtung von Flächen und Räumen oder zur Akzentbeleuchtung
- Große Farben- und Formenvielfalt
- Bis zu 80% Stromersparnis gegenüber Glühlampen, schont Ihr Budget und die Umwelt
- Leuchtmittel tauschbar

Avantages

- Une technologie éprouvée, solutions individuelles dans chaque catégorie de prix
- Selon les lampes choisies apte à éclairer des surfaces et des chambres ou pour l'éclairage accentuel
- Couleurs et formes fantastiques
- Jusqu'à 80% d'économies d'énergie par rapport aux lampes à incandescence, réduit votre budget et protège l'environnement
- Lampe remplaçable

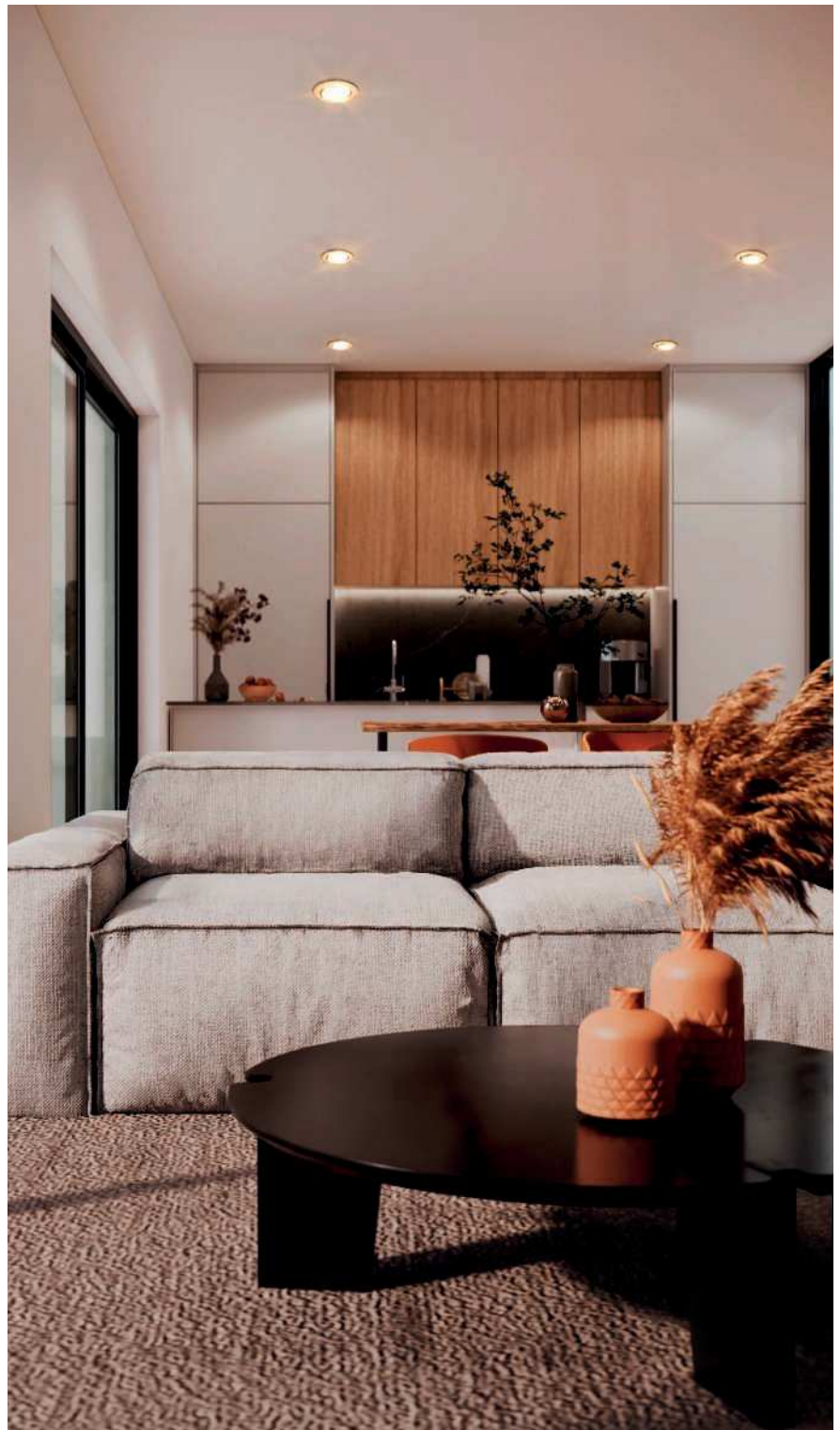

INSTALLATION DEPTH

EINBAUTIEFE

PROFONDEUR D'ENCASTREMENT

Recessed spotlights with replaceable GU10 light sources require an installation depth of at least 85 mm for installation. The replaceable LED pucks from EGLO only require a shallow installation depth of 30 mm for installation and therefore offer a perfect solution for shallow cavities.

Einbauspots mit wechselbaren GU10 Leuchtmittel brauchen eine Einbautiefe von mindestens 85 mm für den Verbau. Die wechselbaren LED Pucks von EGLO benötigen für den Verbau nur eine geringe Einbautiefe von 30 mm und bieten damit ein perfekte Lösung für flache Hohlräume.

Les spots encastrables avec ampoules GU10 interchangeables nécessitent une profondeur d'encastrément d'au moins 85 mm pour être installés. Les LED Pucks interchangeables d'EGLO ne nécessitent qu'une faible profondeur d'encastrément de 30 mm et offrent ainsi une solution parfaite pour les espaces vides peu profonds.

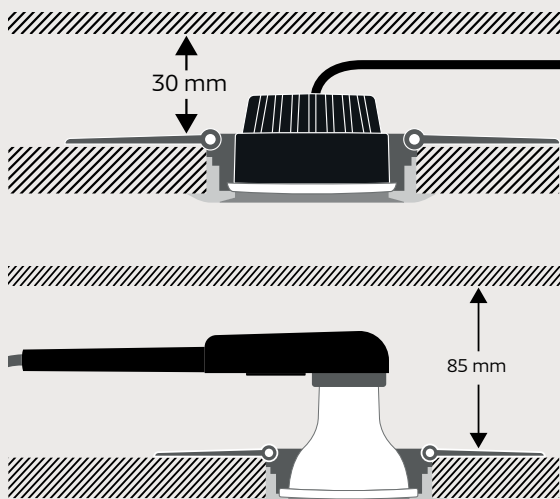

PROTECTION CLASS OVERVIEW

SCHUTZKLASSENÜBERSICHT

APERÇU DES CLASSES DE PROTECTION

Detailed information on the protected areas in the bathroom and living area as well as an explanation of the IP classes can be found on page 4-5.

Detaillierte Informationen zu den Schutzbereichen im Badezimmer und Wohnbereich sowie eine Erklärung zu den IP-Klassen finden Sie auf Seite 4-5.

Vous trouverez des informations détaillées sur les zones de protection dans la salle de bains et le salon ainsi qu'une explication sur les classes IP à la page 4-5.



IP20



IP44



IP65

BARRANCO GU10

With their modern yet timeless design, the luminaires blend harmoniously into various interior styles and are available in black, white, and nickel. They are designed for a ceiling cut-out of 68 mm, allowing easy integration into existing openings, while the tool-free spring mounting ensures quick and simple installation. Thanks to compatibility with standard GU10 light sources as well as EGLO PUCK LED modules, they also offer the flexibility to customize light color and functions such as dimming or smart home control to suit your needs.

Information on the EGLO PUCK models can be found on pages 122–123.

Mit ihrem modernen und zugleich zeitlosen Design fügen sich die Leuchten harmonisch in verschiedene Einrichtungsstile ein und sind in Schwarz, Weiß und Nickel erhältlich. Sie sind für einen Deckenausschnitt von 68 mm konzipiert und können dadurch einfach in bestehende Ausschnitte integriert werden, während die werkzeuglose Klemmbefestigung eine schnelle und unkomplizierte Montage ermöglicht. Dank der Kompatibilität mit klassischen GU10-Leuchtmitteln sowie den EGLO PUCK LED Modulen bieten sie zudem die Möglichkeit, Lichtfarbe und Funktionen wie Dimmbarkeit oder Smart Home individuell an Ihre Bedürfnisse anzupassen.

Informationen zu den EGLO PUCK Modellen finden Sie auf den Seiten 122–123.

Grâce à leur design moderne et intemporel, les luminaires s'intègrent harmonieusement dans différents styles d'intérieur et sont disponibles en noir, blanc et nickel. Conçus pour une découpe de plafond de 68 mm, ils peuvent être facilement intégrés dans des ouvertures existantes, tandis que le système de fixation à ressort sans outil permet une installation rapide et simple. Grâce à leur compatibilité avec des ampoules GU10 classiques ainsi qu'avec les modules LED EGLO PUCK, ils offrent également la possibilité d'adapter individuellement la couleur de lumière et des fonctions telles que la variation ou le contrôle via smart home.

Vous trouverez des informations sur les modèles EGLO PUCK aux pages 122–123.



BARRANCO GU10

These spot heads can be swivelled.

Diese Spot-Köpfe sind schwenkbar.

Ces têtes de spot sont orientables.



INCL. / INKL. / INCLUS

GU10 socket included in the delivery.

GU10 Fassung im Lieferumfang enthalten.

Douille GU10 incluse dans la livraison.













902224, 902225, 902226, 902227, 902228, 902229, 902231, 902232, 902233



BARRANCO GU10

recessed light
Einbauleuchte
luminaire encastrable



Material / Colour	Size	Cutout	Quantity	Material-Nr.	EAN code
 plastic, white Kunststoff, weiss plastique, blanc	Ø 90, ET 25	Ø 68	1	902224	 9008606359066
	Ø 90, ET 25	Ø 68	3	902225	 9008606359097
	Ø 90, ET 25	Ø 68	5	902226	 9008606359127
 plastic, satin nickel Kunststoff, nickel-matt plastique, nickel mat	Ø 90, ET 25	Ø 68	1	902231	 9008606359080
	Ø 90, ET 25	Ø 68	3	902232	 9008606359110
	Ø 90, ET 25	Ø 68	5	902233	 9008606359141
 plastic, black Kunststoff, schwarz plastique, noir	Ø 90, ET 25	Ø 68	1	902227	 9008606359073
	Ø 90, ET 25	Ø 68	3	902228	 9008606359103
	Ø 90, ET 25	Ø 68	5	902229	 9008606359134



BARRANCO GU10

These spot heads can be swivelled.

Diese Spot-Köpfe sind schwenkbar.







































Ces têtes de spot sont orientables.



BARRANCO GU10

recessed light
Einbauleuchte
luminaire encastrable



Material / Colour	Size	Cutout	Watt	Lumen	Quantity	Material-Nr.	EAN code
 plastic, white Kunststoff, weiss plastique, blanc	Ø 90, ET 85	Ø 68	4,5 W	 345 lm		1	902241  9008606359219
	Ø 90, ET 85	Ø 68	4,5 W	 345 lm		1	902254  9008606359332
	Ø 90, ET 85	Ø 68	3 x 4,5 W	 3 x 345 lm		3	902242  9008606359240
	Ø 90, ET 85	Ø 68	3 x 4,5 W	 3 x 345 lm		3	902255  9008606359363
 plastic, satin nickel Kunststoff, nickel-matt plastique, nickel mat	Ø 90, ET 85	Ø 68	4,5 W	 345 lm		1	902245  9008606359233
	Ø 90, ET 85	Ø 68	4,5 W	 345 lm		1	902258  9008606359356
	Ø 90, ET 85	Ø 68	3 x 4,5 W	 3 x 345 lm		3	902246  9008606359264
	Ø 90, ET 85	Ø 68	3 x 4,5 W	 3 x 345 lm		3	902259  9008606359387
 plastic, black Kunststoff, schwarz plastique, noir	Ø 90, ET 85	Ø 68	4,5 W	 345 lm		1	902243  9008606359226
	Ø 90, ET 85	Ø 68	4,5 W	 345 lm		1	902256  9008606359349
	Ø 90, ET 85	Ø 68	3 x 4,5 W	 3 x 345 lm		3	902244  9008606359257
	Ø 90, ET 85	Ø 68	3 x 4,5 W	 3 x 345 lm		3	902257  9008606359370























































BARRANCO GU10

recessed light
Einbauleuchte
luminaire encastrable



Material / Colour	Size	Cutout	Watt		Lumen		IP class	Quantity	Material-Nr.	EAN code
 plastic, white Kunststoff, weiss plastique, blanc	Ø 84, ET 85	Ø 68	4,5 W	 warm WHITE	345 lm		 IP44	1	902234	 9008606359158
	Ø 84, ET 85	Ø 68	4,5 W	 neutral WHITE	345 lm		 IP44	1	902247	 9008606359271
	Ø 84, ET 85	Ø 68	3 x 4,5 W	 warm WHITE	3 x 345 lm		 IP44	3	902235	 9008606359189
	Ø 84, ET 85	Ø 68	3 x 4,5 W	 neutral WHITE	3 x 345 lm		 IP44	3	902248	 9008606359301
 plastic, satin nickel Kunststoff, nickel-matt plastique, nickel mat	Ø 84, ET 85	Ø 68	4,5 W	 warm WHITE	345 lm		 IP44	1	902238	 9008606359172
	Ø 84, ET 85	Ø 68	4,5 W	 neutral WHITE	345 lm		 IP44	1	902252	 9008606359295
	Ø 84, ET 85	Ø 68	3 x 4,5 W	 warm WHITE	3 x 345 lm		 IP44	3	902239	 9008606359202
	Ø 84, ET 85	Ø 68	3 x 4,5 W	 neutral WHITE	3 x 345 lm		 IP44	3	902253	 9008606359325
 plastic, black Kunststoff, schwarz plastique, noir	Ø 84, ET 85	Ø 68	4,5 W	 warm WHITE	345 lm		 IP44	1	902236	 9008606359165
	Ø 84, ET 85	Ø 68	4,5 W	 neutral WHITE	345 lm		 IP44	1	902249	 9008606359288
	Ø 84, ET 85	Ø 68	3 x 4,5 W	 warm WHITE	3 x 345 lm		 IP44	3	902237	 9008606359196
	Ø 84, ET 85	Ø 68	3 x 4,5 W	 neutral WHITE	3 x 345 lm		 IP44	3	902251	 9008606359318





901755, 901756, 901757

These spot heads can be swivelled.

Diese Spot-Köpfe sind schwenkbar.













Ces têtes de spot sont orientables.



FAVAZZINA

recessed light
Einbauleuchte
luminaire encastrable



Material / Colour	Size	Cutout	Watt	Lumen	Quantity	Material-Nr.	EAN code
 steel, white Stahl, weiss acier, blanc	Ø 88, ET 65	Ø 68	3 x 4 W	 3 x 400 lm	 3	901756	 9008606329656
 steel, satin nickel Stahl, nickel-matt acier, nickel mat	Ø 88, ET 65	Ø 68	3 x 4 W	 3 x 400 lm	 3	901757	 9008606329663
 steel, black Stahl, schwarz acier, noir	Ø 88, ET 65	Ø 68	3 x 4 W	 3 x 400 lm	 3	901755	 9008606329649



INCL. / INKL. / INCLUS



Low installation depth despite GU10 socket thanks to the supplied 110351 bulb with low profile.

Niedrige Einbautiefe trotz GU10-Fassung dank des mitgelieferten Leuchtmittels 110351 mit niedrigem Profil.

Faible profondeur d'encastrement malgré la douille GU10 grâce à l'ampoule 110351 à profil bas fournie.









901755, 901756, 901757,
901758, 901759, 901761



FAVAZZINA

recessed light
Einbauleuchte
luminaire encastrable















Material / Colour	Size	Cutout	Watt	Lumen	IP class	Quantity	Material-Nr.	EAN code
 steel, white / glass, clear Stahl, weiss / Glas, klar acier, blanc / verre, transparent	Ø 85, ET 70	Ø 68	3 x 4 W	 3 x 400 lm	IP20/44	3	901759	 9008606329687
 steel, satin nickel / glass, clear Stahl, nickel-matt / Glas, klar acier, nickel mat / verre, transparent	Ø 85, ET 70	Ø 68	3 x 4 W	 3 x 400 lm	IP20/44	3	901761	 9008606329694
 steel, black / glass, clear Stahl, schwarz / Glas, klar acier, noir / verre, transparent	Ø 85, ET 70	Ø 68	3 x 4 W	 3 x 400 lm	IP20/44	3	901758	 9008606329670



PENETO

recessed light
Einbauleuchte
luminaire encastrable





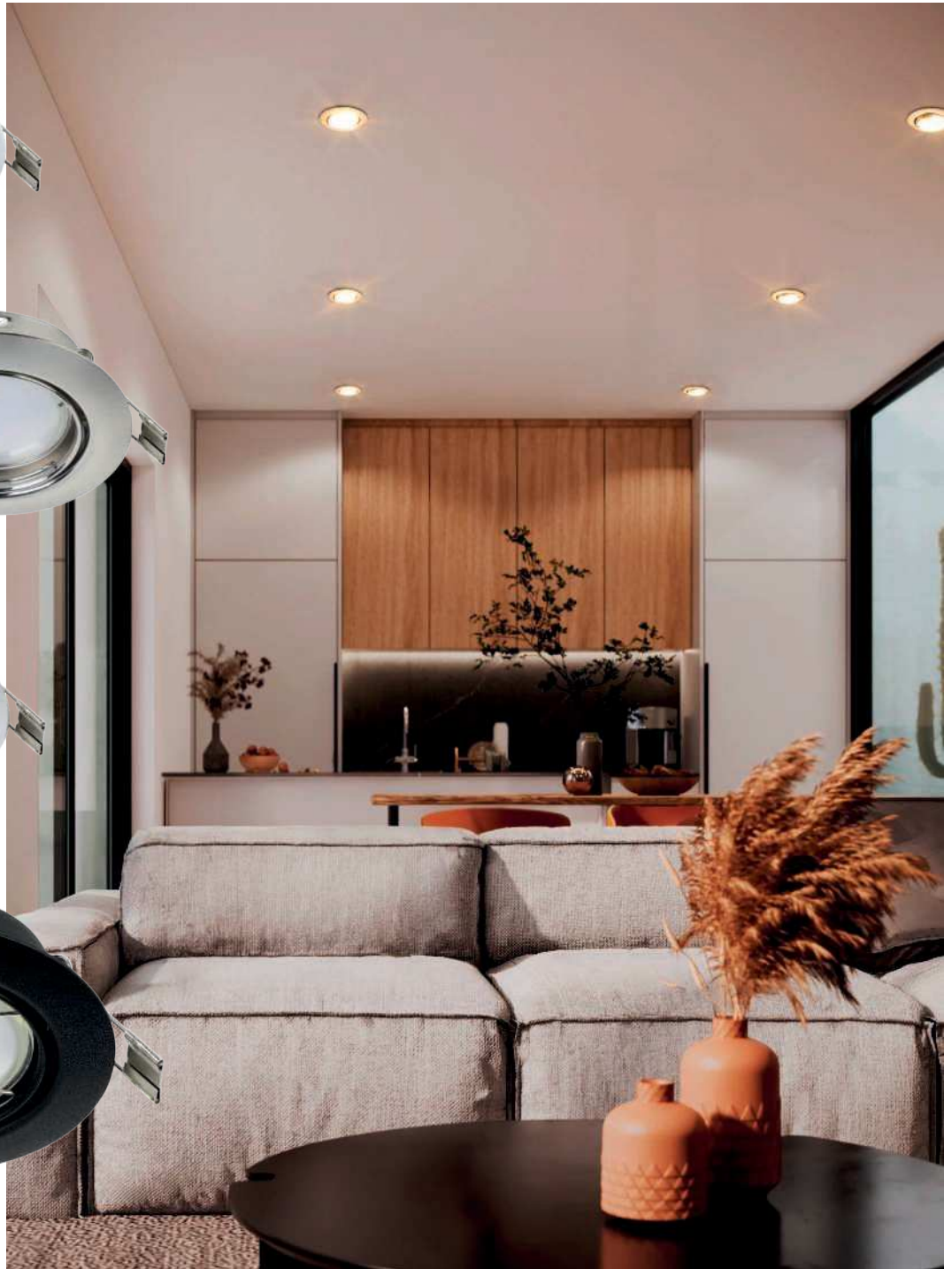















Material / Colour	Size	Cutout	Watt	Lumen	Quantity	Material-Nr.	EAN code
 steel, white Stahl, weiss acier, blanc	Ø 78, ET 115	Ø65	3 x 2,8 W	 3 x 250 lm	 3	94235	 9002759942359
 steel, satin nickel Stahl, nickel-matt acier, nickel mat	Ø 78, ET 115	Ø65	3 x 2,8 W	 3 x 250 lm	 3	94237	 9002759942373
 steel, chrome Stahl, chrom acier, chrome	Ø 78, ET 115	Ø65	3 x 2,8 W	 3 x 250 lm	 3	94236	 9002759942366



PENETO

recessed light
Einbauleuchte
luminaire encastrable



Material / Colour	Size	Cutout	Watt	Lumen	Quantity	Material-Nr.	EAN code
 steel, white Stahl, weiss acier, blanc	Ø 87, ET 115	Ø 70	3 x 4,6 W	 3 x 400 lm	 3	94406	 9002759944063
 steel, satin nickel Stahl, nickel-matt acier, nickel mat	Ø 87, ET 115	Ø 70	4,6 W	 400 lm	 1	94242	 9002759942427
	Ø 87, ET 115	Ø 70	3 x 4,6 W	 3 x 400 lm	 3	94408	 9002759944087
 steel, chrome Stahl, chrom acier, chrome	Ø 87, ET 115	Ø 70	3 x 4,6 W	 3 x 400 lm	 3	94407	 9002759944070
 steel, black Stahl, schwarz acier, noir	Ø 87, ET 115	Ø 70	3 x 4,6 W	 3 x 400 lm	 3	900752	 9008606253845

TEDO 1

DIMMING WITHOUT A DIMMER? No more need for a dimmer - saving you the high initial cost of a modern LED-capable dimmer. If the luminaires are switched off and on again within 3 seconds, they automatically switch to the next dimming level. If the luminaires stay off for more than 3 seconds, they will automatically switch back to 100% brightness the next time they are switched on - saving you the hassle of switching through the luminaires the next day.

Note: Our stepdimming bulbs are only dimmable via on/off switch - operation with conventional dimmers is not intended and could permanently damage the electronics. The bulbs are therefore marked as "not dimmable" according to European regulations.

DIMMEN OHNE DIMMER? Kein Dimmer mehr notwendig - Sie ersparen sich somit hohe Anschaffungskosten für einen modernen LED-fähigen Dimmer. Werden die Leuchten innerhalb von 3 Sekunden aus- und wieder eingeschaltet, wechseln sie automatisch in die nächste Dimmstufe. Bleiben die Leuchten länger als 3 Sekunden ausgeschaltet, stehen Ihnen beim nächsten Einschalten automatisch wieder 100 % Leuchtkraft zur Verfügung - Sie ersparen sich also das mühsame Durchschalten am nächsten Tag.

Hinweis: Unsere Stepdimming-Leuchtmittel sind nur über Ein-/Ausschalter dimmbar - der Betrieb mit konventionellen Dimmern ist nicht vorgesehen und könnte die Elektronik dauerhaft beschädigen. Die Leuchtmittel werden daher gemäß europäischer Vorschriften als „nicht dimmbar“ gekennzeichnet.

FAIRE VARIER L'INTENSITÉ DES LUMINAIRES SANS VARIATEUR ? Plus besoin de variateur - vous vous épargnez ainsi des frais d'achat élevés pour un variateur moderne compatible avec les LED. Si les luminaires sont éteints puis rallumés en moins de 3 secondes, ils passent automatiquement au niveau de gradation suivant. Si les luminaires restent éteints pendant plus de 3 secondes, vous disposez à nouveau automatiquement de 100 % de la puissance d'éclairage lors du prochain allumage - vous vous épargnez ainsi la fastidieuse commutation le lendemain.

Remarque : Nos lampes Stepdimming ne sont gradables qu'à l'aide d'un interrupteur marche/arrêt - le fonctionnement avec des variateurs conventionnels n'est pas prévu et pourrait endommager durablement l'électronique. Les ampoules sont donc marquées comme «non dimmables» conformément à la réglementation européenne.

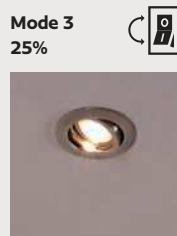
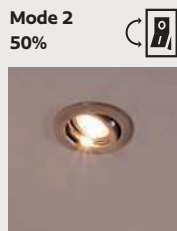

TEDO 1
DETAIL

TEDO 1

These spot heads can be swivelled.

Diese Spot-Köpfe sind schwenkbar.

Ces têtes de spot sont orientables.



95359 TEDO 1

recessed light; cast aluminium, satin nickel
Einbauleuchte; Aluguss, nickel-matt
luminaire encastrable; fonte d'aluminium,
nickel mat

Ø 80, ET 115



GU10



3 x
4,8 W



warm
WHITE
3 x
400 lm



Ø 68



9002759953591



INCL.



900816

CAROSSO

Replaceable bulb, compatible with:

Leuchtmittel tauschbar, kompatibel mit:

Ampoule interchangeable, compatible avec :

- > PUCK CCT
- > PUCK CCT/DIM
- > PUCK COB WW
- > PUCK COB NW
- > PUCK SMART RGB+TW

Learn more on pages 8-9.

Mehr erfahren Sie auf den Seiten 8-9.

En savoir plus aux pages 8-9.



900456

900816 CAROSSO

recessed light; aluminium, white

Einbauleuchte; Alu, weiss

luminaire encastrable; aluminium, blanc

↕ Ø 93, ET 35



GU10

1 x
35 W

Ø80

900456 CAROSSO

recessed light; aluminium, white, black

Einbauleuchte; Alu, weiss, schwarz

luminaire encastrable; aluminium, blanc, noir

↕ Ø 93, ET 35

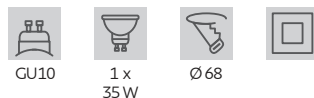

GU10

1 x
35 W

Ø68



9008606259243



9008606238811

INCL. / INKL. / INCLUS

GU10 socket included in the delivery.

GU10 Fassung im Lieferumfang enthalten.

Douille GU10 incluse dans la livraison.

900456, 900816



SURFACE DOWNLIGHTS

AUFBAULEUCHTEN

LUMINAIRES DE SURFACE



Collection
Produktwelt
Univers produit

EN

VERSATILE SURFACE-MOUNTED LUMINAIRES FOR MODERN INTERIORS

Subtle in appearance yet impressive in effect – surface-mounted luminaires stylishly highlight your home. Designed for flexible installation on ceilings or walls, they stand out for their ease of use and clean design language.

Thanks to integrated LED boards or high-quality LED light sources, they are particularly energy-efficient, power-saving and long-lasting. Surface-mounted luminaires combine contemporary design with functional lighting and economic efficiency.

DE

VIELSEITIGE AUFBAULEUCHTEN FÜR MODERNE RAUMGESTALTUNG

Dezent im Auftreten und wirkungsvoll in der Inszenierung – Aufbauleuchten setzen Ihr Zuhause stilvoll in Szene. Sie lassen sich flexibel an Decken oder Wänden montieren und überzeugen durch ihre unkomplizierte Anwendung sowie ihre klare Formensprache.

Dank integrierter LED-Platinen oder hochwertiger LED-Leuchtmittel sind sie besonders energieeffizient, stromsparend und langlebig. So verbinden Aufbauleuchten modernes Design mit funktionaler Beleuchtung und wirtschaftlicher Effizienz.

FR

LUMINAIRES EN SAILLIE POLYVALENTS POUR DES INTÉRIEURS MODERNES

Discrets dans leur apparence et efficaces dans leur mise en scène – les luminaires en saillie subliment votre intérieur avec élégance. Conçus pour une installation flexible au plafond ou au mur, ils séduisent par leur simplicité d'utilisation et leur design épuré.

Grâce aux platines LED intégrées ou aux sources lumineuses LED de haute qualité, ils sont particulièrement économes en énergie, durables et rentables. Les luminaires en saillie associent ainsi design contemporain, fonctionnalité et efficacité économique.



FUEVA 6

The luminaires impress with their quick and easy installation, requiring minimal effort. Their robust and durable frame ensures high resistance, while the clean, modern design seamlessly blends into any contemporary home. With a high lumen output, it provides exceptional brightness for optimal lighting. The replaceable LED driver allows for long-term use, ensuring reliability. The dip switch version enables you to select the light colour that best suits your space.

Die Leuchten überzeugen durch ihre einfache und schnelle Installation, die ohne großen Aufwand durchgeführt werden kann. Dank des robusten und langlebigen Rahmens sind sie besonders widerstandsfähig und fügen sich mit ihrem sauberen, modernen Design harmonisch in jedes zeitgemäße Wohnambiente ein. Der hohe Lumen-Output sorgt für außergewöhnliche Helligkeit und optimale Beleuchtung. Ein weiterer Vorteil ist der austauschbare LED-Treiber, der eine langfristige Nutzung ermöglicht. Die Dip-Switch-Version erlaubt es, die Lichtfarbe individuell an den Raum anzupassen.

Les luminaires séduisent par leur installation simple et rapide, qui peut être effectuée sans grand effort. Grâce à leur cadre robuste et durable, ils sont particulièrement résistants et s'intègrent harmonieusement dans tout intérieur contemporain grâce à leur design propre et moderne. Grâce à son haut rendement lumineux, il offre une luminosité exceptionnelle pour un éclairage optimal. Son driver LED remplaçable assure une utilisation à long terme en toute fiabilité. La version avec interrupteur DIP permet d'adapter la couleur de la lumière à votre espace.



SHAPE
FORM
FORME

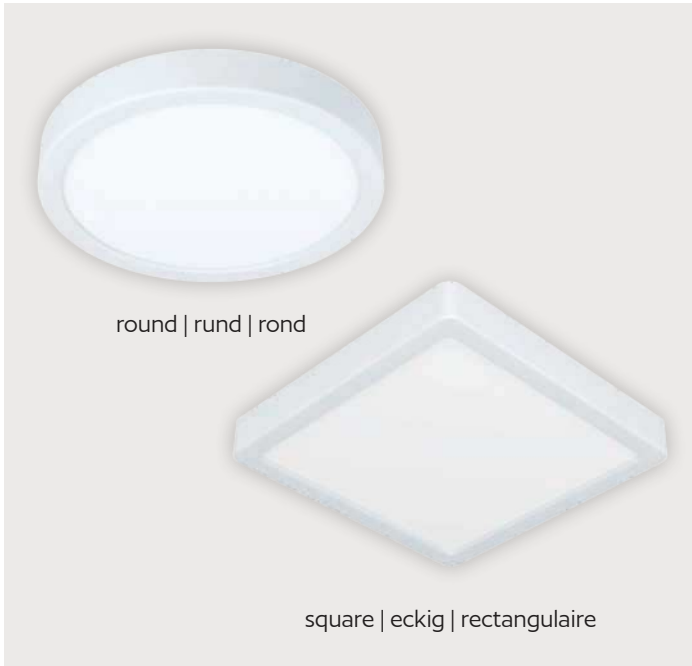

FORM
BAUFORM
CONCEPTION

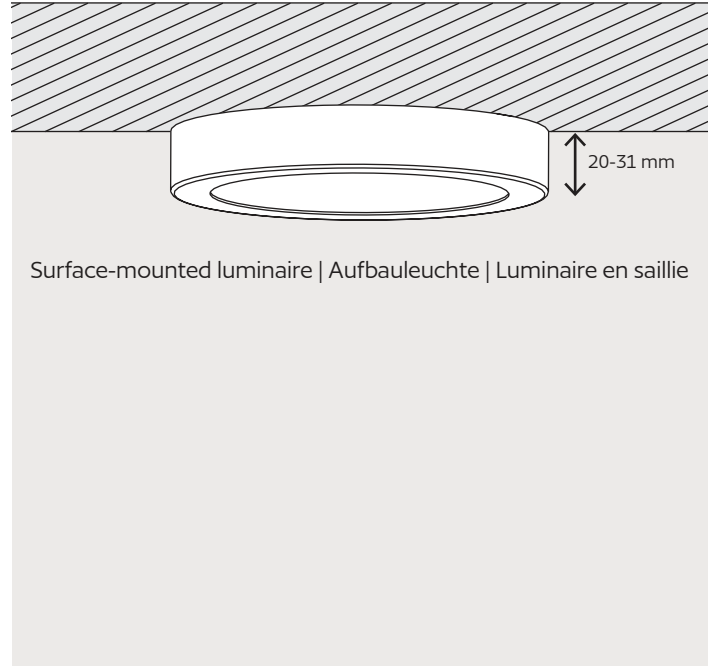

LIGHT COLOURS
LICHTFARBEN
COULEURS DE LUMIÈRE



EASY MOUNTING
EINFACHE MONTAGE
MONTAGE FACILE



POS SOLUTIONS

POS LÖSUNGEN
SOLUTIONS POS

We offer you numerous sales promoting solutions to help you sell our EGLO FUEVA 6 luminaires in the best possible way. Your EGLO account manager will be happy to advise you for your individual solution.

Wir bieten Ihnen zahlreiche verkaufsfördernde Lösungen an, damit Sie die EGLO FUEVA 6 Leuchten bestmöglich verkaufen können. Ihr EGLO Kundenbetreuer berät Sie gerne für Ihre individuelle Lösung.

Nous vous proposons de nombreuses solutions de promotion des ventes pour vous aider à vendre nos luminaires EGLO FUEVA 6 de la meilleure façon possible. Votre responsable de compte EGLO se fera un plaisir de vous conseiller pour votre solution individuelle.

Advantages

- Clear presentation with intuitive icons
- Products take center stage - no cluttered POS
- Realistic representation on a white background, as most customers have white ceilings
- Space for product highlights such as installation instructions and dip switch explanations

Vorteile

- Übersichtliche Darstellung mit intuitiven Symbolen
- Produkte stehen im Vordergrund, kein überladener POS
- Für eine realistische Darstellung auf weißem Hintergrund, da die meisten Kunden weiße Decken haben
- Erklärung für Produkthighlights wie Montageanleitung und Dipswitch

Avantages

- Présentation claire avec des icônes intuitives
- Les produits sont au premier plan, sans PLV surchargée
- Représentation réaliste sur un fond blanc, car la plupart des clients ont des plafonds blancs
- Espace pour les points forts du produit, tels que le manuel d'installation et l'explication du dip switch































FUEVA 6

surface-mounted light
Aufbauleuchte
luminaire en saillie



Material / Colour	Size	Watt		Lumen		IP class	Material-Nr.	EAN code
 plastic, white / plastic, white Kunststoff, weiss / Kunststoff, weiss plastique, blanc / plastique, blanc	H 25, Ø 166	7,5 W		1000 lm			901306	 9008606330140
	H 25, Ø 166	7,5 W		1000 lm		 IP44	901332	 9008606330362
 steel, satin nickel / plastic, white Stahl, nickel-matt / Kunststoff, weiss acier, nickel mat / plastique, blanc	H 25, Ø 166	7,5 W		1000 lm			901315	 9008606330225
 steel, chrome / plastic, white Stahl, chrom / Kunststoff, weiss acier, chrome / plastique, blanc	H 25, Ø 166	7,5 W		1000 lm		 IP44	901762	 9008606331055
 plastic, black / plastic, white Kunststoff, schwarz / Kunststoff, weiss plastique, noir / plastique, blanc	H 25, Ø 166	7,5 W		1000 lm			901297	 9008606330065
	H 25, Ø 166	7,5 W		1000 lm		 IP44	901324	 9008606330300



FUEVA 6

surface-mounted light
Aufbauleuchte
luminaire en saillie



























Material / Colour	Size	Watt	Lumen	IP class	Material-Nr.	EAN code
plastic, white / plastic, white Kunststoff, weiss / Kunststoff, weiss plastique, blanc / plastique, blanc	H 25, Ø 211	11,5 W	1550 lm			901307 9008606330157
	H 25, Ø 211	11,5 W	1550 lm	IP44	901333 9008606330379	
steel, satin nickel / plastic, white Stahl, nickel-matt / Kunststoff, weiss acier, nickel mat / plastique, blanc	H 25, Ø 211	11,5 W	1550 lm		901316 9008606330252	
steel, chrome / plastic, white Stahl, chrom / Kunststoff, weiss acier, chrome / plastique, blanc	H 25, Ø 211	11,5 W	1550 lm	IP44	901763 9008606331062	
plastic, black / plastic, white Kunststoff, schwarz / Kunststoff, weiss plastique, noir / plastique, blanc	H 25, Ø 211	11,5 W	1550 lm		901298 9008606330072	
	H 25, Ø 211	11,5 W	1550 lm	IP44	901325 9008606330317	



FUEVA 6

surface-mounted light
Aufbauleuchte
luminaire en saillie













Material / Colour	Size	Watt		Lumen		IP class	Material-Nr.	EAN code
 plastic, white / plastic, white Kunststoff, weiss / Kunststoff, weiss plastique, blanc / plastique, blanc	H 25, Ø 278	14,2 W		2000 lm			901308	 9008606330164
	H 25, Ø 278	14,2 W		2000 lm		 IP44	901334	 9008606330386
 steel, satin nickel / plastic, white Stahl, nickel-matt / Kunststoff, weiss acier, nickel mat / plastique, blanc	H 25, Ø 278	14,2 W		2000 lm			901317	 9008606330249
 steel, chrome / plastic, white Stahl, chrom / Kunststoff, weiss acier, chrome / plastique, blanc	H 25, Ø 278	14,2 W		2000 lm		 IP44	901764	 9008606331079
 plastic, black / plastic, white Kunststoff, schwarz / Kunststoff, weiss plastique, noir / plastique, blanc	H 25, Ø 278	14,2 W		2000 lm			901299	 9008606330089
	H 25, Ø 278	14,2 W		2000 lm		 IP44	901326	 9008606330324



FUEVA 6

surface-mounted light
Aufbauleuchte
luminaire en saillie



























Material / Colour	Size	Watt		Lumen		Material-Nr.	EAN code
 plastic, white / plastic, white Kunststoff, weiss / Kunststoff, weiss plastique, blanc / plastique, blanc	H 25, Ø 389	17 W		2900 lm		901309	 9008606330171
 steel, satin nickel / plastic, white Stahl, nickel-matt / Kunststoff, weiss acier, nickel mat / plastique, blanc	H 25, Ø 389	17 W		2900 lm		901318	 9008606330256
 plastic, black / plastic, white Kunststoff, schwarz / Kunststoff, weiss plastique, noir / plastique, blanc	H 25, Ø 389	17 W		2900 lm		901301	 9008606330096



FUEVA 6

surface-mounted light
Aufbauleuchte
luminaire en saillie



Material / Colour	Size	Watt	Lumen	IP class	Material-Nr.	EAN code
 plastic, white / plastic, white Kunststoff, weiss / Kunststoff, weiss plastique, blanc / plastique, blanc	L 150, B 150, H 25	7 W	 1100 lm		901311	 9008606330188
	L 150, B 150, H 25	7 W	 1100 lm	  IP44	901335	 9008606330393
 steel, satin nickel / plastic, white Stahl, nickel-matt / Kunststoff, weiss acier, nickel mat / plastique, blanc	L 150, B 150, H 25	7 W	 1100 lm		901319	 9008606330263
 steel, chrome / plastic, white Stahl, chrom / Kunststoff, weiss acier, chrome / plastique, blanc	L 150, B 150, H 25	7 W	 1100 lm	  IP44	901765	 9008606331086
 plastic, black / plastic, white Kunststoff, schwarz / Kunststoff, weiss plastique, noir / plastique, blanc	L 150, B 150, H 25	7 W	 1100 lm		901302	 9008606330102
	L 150, B 150, H 25	7 W	 1100 lm	  IP44	901328	 9008606330331



FUEVA 6

surface-mounted light
Aufbauleuchte
luminaire en saillie



Material / Colour	Size	Watt	Lumen	IP class	Material-Nr.	EAN code
plastic, white / plastic, white Kunststoff, weiss / Kunststoff, weiss plastique, blanc / plastique, blanc	L 220, B 220, H 25	10,5 W	1700 lm		901312	9008606330195
	L 220, B 220, H 25	10,5 W	1700 lm	IP44	901336	9008606330409
steel, satin nickel / plastic, white Stahl, nickel-matt / Kunststoff, weiss acier, nickel mat / plastique, blanc	L 220, B 220, H 25	10,5 W	1700 lm		901321	9008606330270
steel, chrome / plastic, white Stahl, chrom / Kunststoff, weiss acier, chrome / plastique, blanc	L 220, B 220, H 25	10,5 W	1700 lm	IP44	901766	9008606331093
plastic, black / plastic, white Kunststoff, schwarz / Kunststoff, weiss plastique, noir / plastique, blanc	L 220, B 220, H 25	10,5 W	1700 lm		901303	9008606330119
	L 220, B 220, H 25	10,5 W	1700 lm	IP44	901329	9008606330348



FUEVA 6

surface-mounted light
Aufbauleuchte
luminaire en saillie















Material / Colour	Size	Watt	COLOUR	Lumen	IP class	Material-Nr.	EAN code
plastic, white / plastic, white Kunststoff, weiss / Kunststoff, weiss plastique, blanc / plastique, blanc	L 290, B 290, H 25	13 W		2100 lm		901313	 9008606330201
	L 290, B 290, H 25	13 W		2100 lm		901337	 9008606330416
steel, satin nickel / plastic, white Stahl, nickel-matt / Kunststoff, weiss acier, nickel mat / plastique, blanc	L 290, B 290, H 25	13 W		2100 lm		901322	 9008606330287
steel, chrome / plastic, white Stahl, chrom / Kunststoff, weiss acier, chrome / plastique, blanc	L 290, B 290, H 25	13 W		2100 lm		901767	 9008606331109
plastic, black / plastic, white Kunststoff, schwarz / Kunststoff, weiss plastique, noir / plastique, blanc	L 290, B 290, H 25	13 W		2100 lm		901304	 9008606330126
	L 290, B 290, H 25	13 W		2100 lm		901331	 9008606330355



FUEVA 6

surface-mounted light
Aufbauleuchte
luminaire en saillie



Material / Colour	Size	Watt	Lumen	Material-Nr.	EAN code
 plastic, white / plastic, white Kunststoff, weiss / Kunststoff, weiss plastique, blanc / plastique, blanc	L 390, B 390, H 25	17,5 W	 2800 lm	 901314	 9008606330218
 steel, satin nickel / plastic, white Stahl, nickel-matt / Kunststoff, weiss acier, nickel mat / plastique, blanc	L 390, B 390, H 25	17,5 W	 2800 lm	 901323	 9008606330294
 plastic, black / plastic, white Kunststoff, schwarz / Kunststoff, weiss plastique, noir / plastique, blanc	L 390, B 390, H 25	17,5 W	 2800 lm	 901305	 9008606330133



FUEVA 5

surface-mounted light
Aufbauleuchte
luminaire en saillie















Material / Colour	Size	Watt	Lumen	IP class	Sensor	Material-Nr.	EAN code
steel, white / plastic, white Stahl, weiss / Kunststoff, weiss acier, blanc / plastique, blanc	H 28, Ø 210	17 W	2000 lm			99258	9002759992583
	H 28, Ø 210	17 W	2000 lm		160°, 2 m 20 sec.	901011	9008606299508
	H 28, Ø 285	20,5 W	2400 lm			99259	9002759992590
	H 28, Ø 285	20,5 W	2400 lm		160°, 2 m 20 sec.	901012	9008606299515
steel, brushed brass / plastic, white Stahl, messing-gebürstet / Kunststoff, weiss acier, laiton brossé / plastique, blanc	H 28, Ø 210	17 W	2000 lm			900181	9008606229567
	H 28, Ø 285	20,5 W	2400 lm			900182	9008606229574
steel, black / plastic, white Stahl, schwarz / Kunststoff, weiss acier, noir / plastique, blanc	H 28, Ø 210	17 W	2000 lm			99263	9002759992637
	H 28, Ø 210	17 W	2000 lm		160°, 2 m 20 sec.	901013	9008606299522
	H 28, Ø 285	20,5 W	2400 lm			99264	9002759992644
	H 28, Ø 285	20,5 W	2400 lm		160°, 2 m 20 sec.	901014	9008606299539
	H 28, Ø 285	20,5 W	2500 lm		IP44	30761	9002759307615



FUEVA 5

surface-mounted light
Aufbauleuchte
luminaire en saillie



Material / Colour	Size	Watt	Lumen	IP class	Material-Nr.	EAN code
 steel, brushed brass / plastic, white Stahl, messing-gebürstet / Kunststoff, weiss acier, laiton brossé / plastique, blanc	L 210, B 210, H 28	17 W	 2000 lm		900183	 9008606229581
	L 285, B 285, H 28	20,5 W	 2400 lm		900184	 9008606229598
 steel, black / plastic, white Stahl, schwarz / Kunststoff, weiss acier, noir / plastique, blanc	L 285, B 285, H 30	20,5 W	 2500 lm	  IP44	30762	 9002759307622

FUEVA 1

The FUEVA 1 is the ideal choice for those who value high-quality craftsmanship and minimalist design. With its slim and wide-surface construction, it provides uniform illumination and blends harmoniously into any environment.

Die FUEVA 1 ist die ideale Wahl für alle, die Wert auf hochwertige Verarbeitung und ein minimalistisches Design legen. Durch ihre flache und weitflächige Bauweise sorgt sie für eine gleichmäßige Ausleuchtung und fügt sich harmonisch in jede Umgebung ein.









La FUEVA 1 est le choix idéal pour ceux qui apprécient une fabrication de haute qualité et un design minimaliste. Grâce à sa conception plate et étendue, elle assure un éclairage uniforme et s'intègre harmonieusement dans tous les environnements.



FUEVA 1

surface-mounted light
Aufbauleuchte
luminaire en saillie







Material / Colour	Size	Watt	Lumen	Material-Nr.	EAN code
 aluminium, white / plastic, white Alu, weiss / Kunststoff, weiss aluminium, blanc / plastique, blanc	H 30, Ø 400	22,3 W	 2500 lm	 97262	 9002759972622
 aluminium, silver / plastic, white Alu, silber / Kunststoff, weiss aluminium, argent / plastique, blanc	H 30, Ø 400	22,3 W	 2500 lm	 97263	 9002759972639



FUEVA 1

surface-mounted light
Aufbauleuchte
luminaire en saillie



Material / Colour	Size	Watt	Lumen	Material-Nr.	EAN code
 aluminium, white / plastic, white Alu, weiss / Kunststoff, weiss aluminium, blanc / plastique, blanc	L 400, B 400, H 30	22 W	 2600 lm	 97268	 9002759972684

CRESPILLO

Our CRESPILO surface-mounted luminaires combine functionality with a touch of individuality. They provide pleasant illumination and blend harmoniously into different interior styles. With high-quality materials, they offer a versatile solution for different room concepts.

Unsere CRESPILO Aufbauleuchten vereinen Funktionalität mit einem Hauch von Individualität. Sie sorgen für eine angenehme Ausleuchtung und fügen sich harmonisch in unterschiedliche Wohnstile ein. Mit hochwertigen Materialien bieten sie eine vielseitige Lösung für verschiedene Raumkonzepte.

Nos luminaires en saillie CRESPILO allient fonctionnalité et une touche d'individualité. Ils assurent un éclairage agréable et s'intègrent harmonieusement dans différents styles d'habitat. Avec des matériaux de haute qualité, ils offrent une solution polyvalente pour différents concepts d'espace.



99337



99338



99726



99727

99337 CRESPILO

surface-mounted light; plastic, steel, white / plastic, white

Aufbauleuchte; Kunststoff, Stahl, weiss / Kunststoff, weiss

luminaire en saillie; plastique, acier, blanc / plastique, blanc

H 45, Ø 240



1 x 12,5 W
1 x 1350 lm

99338 CRESPILO

surface-mounted light; plastic, steel, white / plastic, white

Aufbauleuchte; Kunststoff, Stahl, weiss / Kunststoff, weiss

luminaire en saillie; plastique, acier, blanc / plastique, blanc

H 45, Ø 315



1 x 15 W
1 x 1800 lm

99726 CRESPILO

surface-mounted light; plastic, white / plastic, white

Aufbauleuchte; Kunststoff, weiss / Kunststoff, weiss

luminaire en saillie; plastique, blanc / plastique, blanc

H 65, Ø 380



1 x 21 W
1 x 3000 lm

99727 CRESPILO

surface-mounted light; plastic, white / plastic, white

Aufbauleuchte; Kunststoff, weiss / Kunststoff, weiss

luminaire en saillie; plastique, blanc / plastique, blanc

H 65, Ø 500



1 x 29 W
1 x 4800 lm



9002759993375



9002759993382



9002759997267



9002759997274



93706



93707

93706 KOB LED

under cabinet light; steel, white
Unterbauleuchte; Stahl, weiss
éclairage de meuble; acier, blanc

⌋ L 600, B 70, H 25



3 x
2,3 W



3 x
280 lm



93707 KOB LED

under cabinet light; steel, satin nickel
Unterbauleuchte; Stahl, nickel-matt
éclairage de meuble; acier, nickel mat

⌋ L 600, B 70, H 25



3 x
2,3 W



3 x
280 lm



9002759937065



9002759937072

INCL./INKL./INCLUS

Thanks to the included cable, the under-cabinet luminaires can be easily extended and connected to additional luminaires.

Dank des beiliegenden Kabels lassen sich die Unterbauleuchten mühelos erweitern und mit weiteren Leuchten verbinden.

Grâce au câble fourni, les luminaires d'appoint peuvent être facilement étendus et reliés à d'autres lampes.

93706, 93707

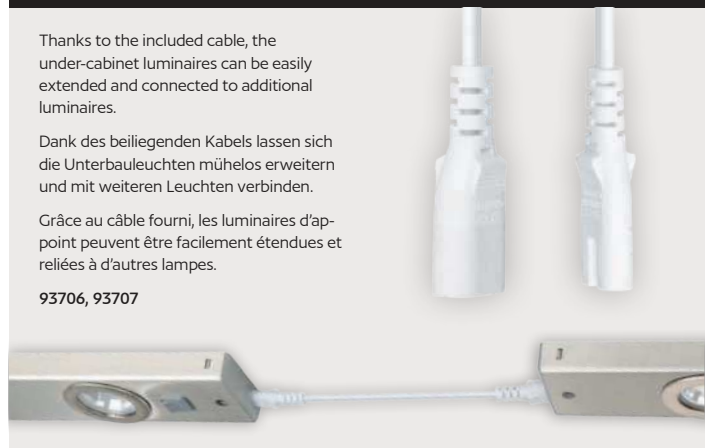



94501



94503



94502



94501 POLASSO

ceiling light; aluminium, plastic, black, copper
 Deckenleuchte; Alu, Kunststoff, schwarz, kupfer
 plafonnier; aluminium, plastique, noir, cuivre

⌄ H 120, Ø 100



1 x
3,3 W



1 x
340 lm



94503 POLASSO

ceiling light; aluminium, plastic, white, gold
 Deckenleuchte; Alu, Kunststoff, weiss, gold
 plafonnier; aluminium, plastique, blanc, or

⌄ H 120, Ø 100



1 x
3,3 W



1 x
340 lm



94502 POLASSO

ceiling light; aluminium, plastic, black, gold
 Deckenleuchte; Alu, Kunststoff, schwarz, gold
 plafonnier; aluminium, plastique, noir, or

⌄ H 120, Ø 100



1 x
3,3 W



1 x
340 lm



9002759945015



9002759945039



9002759945022



901044

901043

901044 BOHOYO

spot; aluminium, black / plastic, transparent
Spot; Alu, schwarz / Kunststoff, transparent
spot; aluminium, noir / plastique, transparent

901043 BOHOYO

spot; aluminium, white / plastic, transparent
Spot; Alu, weiss / Kunststoff, transparent
spot; aluminium, blanc / plastique, transparent

↻ L 100, H 110, ET 40



1 x
8 W



1 x
1000 lm



↻ L 100, H 110, ET 40



1 x
8 W



1 x
1000 lm



9008606315956



9008606315949

BOHOYO

These luminaires can be used as recessed or surface-mounted luminaires. The heads of the luminaires are movable and can be rotated.

Diese Leuchten können als Ein- oder Aufbauleuchten verwendet werden. Die Köpfe der Leuchten sind beweglich und können gedreht werden.

Ces luminaires peuvent être utilisés comme luminaires encastrés ou apparents. La tête des luminaires est mobile et peut être orientée.



GLOW

GLOW

GLOW



Collection
Produktwelt
Univers produit

EN

GLOW – FLEXIBLE ROPE LIGHTS FOR MODERN INTERIORS

Subtle in design yet impressive in effect – GLOW creates stylish lighting accents in modern living spaces. The flexible rope lights open up new possibilities for interior lighting and can be used in many ways on ceilings, walls or even freely within a room. This allows for individual lighting concepts that offer a modern alternative to traditional lighting solutions while adding a special atmosphere to any space.

DE

GLOW – FLEXIBLE LICHTSCHLÄUCHE FÜR MODERNE WOHNÄRÄUME

Dezent im Design und dennoch wirkungsvoll in der Inszenierung – GLOW setzt stilvolle Lichtakzente in modernen Wohnräumen. Die flexiblen Lichtschläuche eröffnen neue Möglichkeiten der Raumbelichtung und lassen sich vielseitig an Decken, Wänden oder auch frei im Raum einsetzen. So entstehen individuelle Lichtgestaltungen, die eine moderne Alternative zu klassischen Beleuchtungslösungen bieten und Räumen eine besondere Atmosphäre verleihen.

FR

GLOW – TUBES LUMINEUX FLEXIBLES POUR INTÉRIEURS MODERNES

Discret dans son design mais remarquable dans son effet – GLOW apporte des accents lumineux élégants aux espaces de vie modernes. Les tubes lumineux flexibles offrent de nouvelles possibilités d'éclairage et peuvent être installés de multiples façons au plafond, au mur ou même librement dans la pièce. Ils permettent de créer des concepts d'éclairage personnalisés, offrant une alternative moderne aux solutions d'éclairage traditionnelles tout en apportant une atmosphère particulière aux espaces.

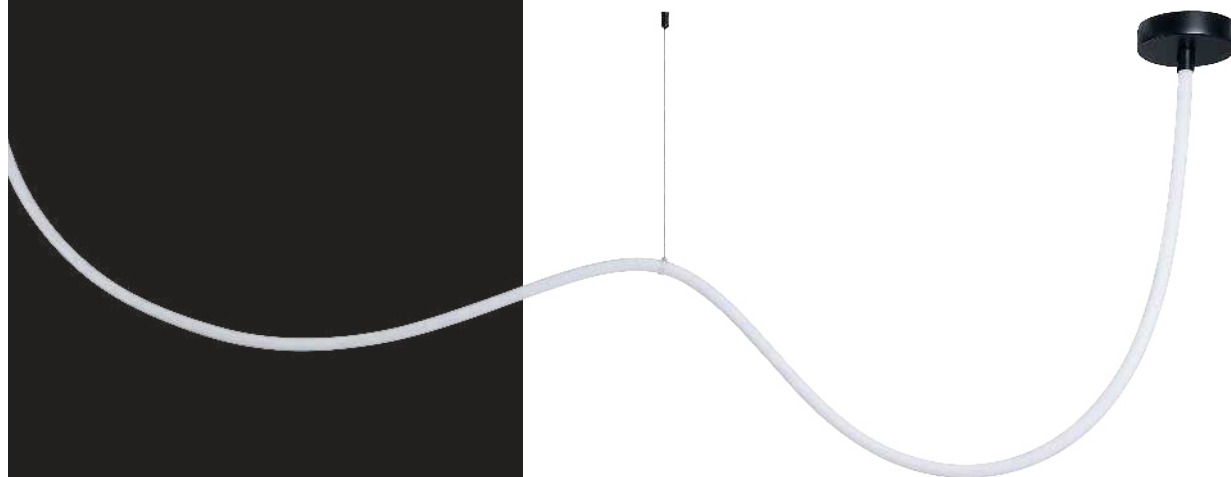



AREAS OF APPLICATION

EINSATZBEREICHE

DOMAINES D'APPLICATION

A modern eye-catcher for any room that never needs to be the center of attention. GLOW adds stylish accents to your dining table, living room, or kitchen and blends seamlessly into your home.

Ein moderner Blickfang für jeden Raum, der nie zu sehr im Mittelpunkt stehen muss. Die GLOW bringt stilvolle Akzente über den Esstisch, ins Wohnzimmer oder die Küche und integriert sich fließend in Ihr Zuhause.

Un élément moderne qui attire le regard sans jamais voler la vedette. La GLOW apporte des touches élégantes au-dessus de la table à manger, dans le salon ou la cuisine et s'intègre harmonieusement dans votre intérieur.

LIVING AREAS & HALLWAYS

WOHNBEREICHE & FLUR

ESPACES DE VIE ET COULOIR

As a modern alternative to spotlights, GLOW brings clean lines and stylish accents to the ceiling.

Als moderne Alternative zu Spots bringt die GLOW klare Linien und stilvolle Akzente an die Decke.

Alternative moderne aux spots, la GLOW apporte des lignes épurées et des accents élégants au plafond.

DACHSCHRÄGEN & ECKEN

SLOPING CEILINGS & CORNERS

COMBLES ET COINS

Whether sloping, narrow, or winding, GLOW adapts flexibly to any room structure.

Ob schräg, eng oder verwinkelt, die GLOW passt sich jeder Raumstruktur flexibel an.

Qu'il s'agisse d'un espace incliné, étroit ou irrégulier, la GLOW s'adapte avec flexibilité à chaque structure de pièce.

KITCHEN ISLAND & OPEN KITCHEN

KÜCHENINSEL & OFFENE KÜCHE

ÎLOT DE CUISINE ET CUISINE OUVERTE

GLOW combines cooking and living with atmospheric lighting.

Die GLOW verbindet Kochen und Wohnen mit atmosphärischer Beleuchtung.

La GLOW relie la cuisine et le séjour avec un éclairage d'ambiance.



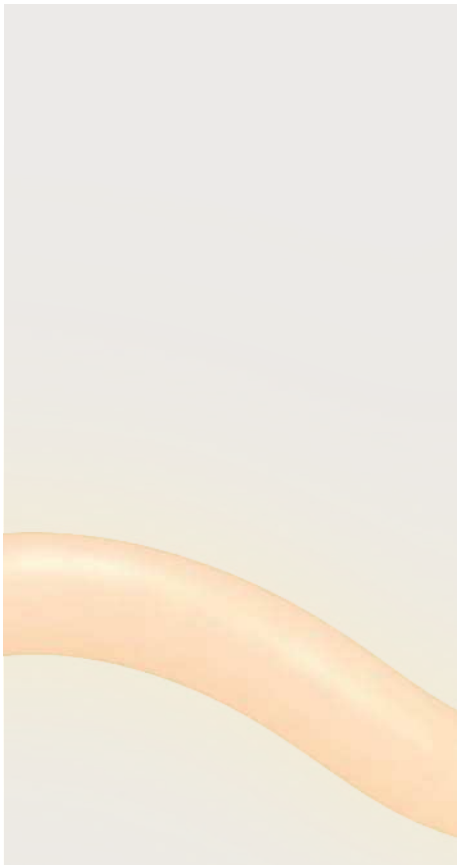

Warm white – Perfect for relaxed living areas.
 Warmweiß – Perfekt für entspannte Wohnbereiche.
 Blanc chaud – Parfait pour les espaces de vie détendus.



Neutral white – Ideal for functional areas.
 Neutralweiß – Ideal für funktionale Bereiche.
 Blanc neutre – Idéal pour les espaces fonctionnels.



RGB & warm white – Full colour freedom and can be adjusted at any time by remote control.
 RGB & Warmweiß – Volle Farbfreiheit und per Fernbedienung anpassbar.
 RVB et blanc chaud – Liberté totale des couleurs et réglable via télécommande.



COMPLETE SET INCLUDING MOUNTING MATERIALS

KOMPLETTSET INKLUSIVE MONTAGEMATERIAL
 KIT COMPLET AVEC MATÉRIEL DE MONTAGE

Everything you need for easy modernization without structural work - flexible mounting on walls, ceilings, or suspended.

Alles dabei für eine einfache Modernisierung ohne bauliche Maßnahmen - flexible Montage an Wand, Decke oder abgehängt.

Tout ce qu'il faut pour une modernisation simple, sans travaux - montage flexible au mur, au plafond ou en suspension.

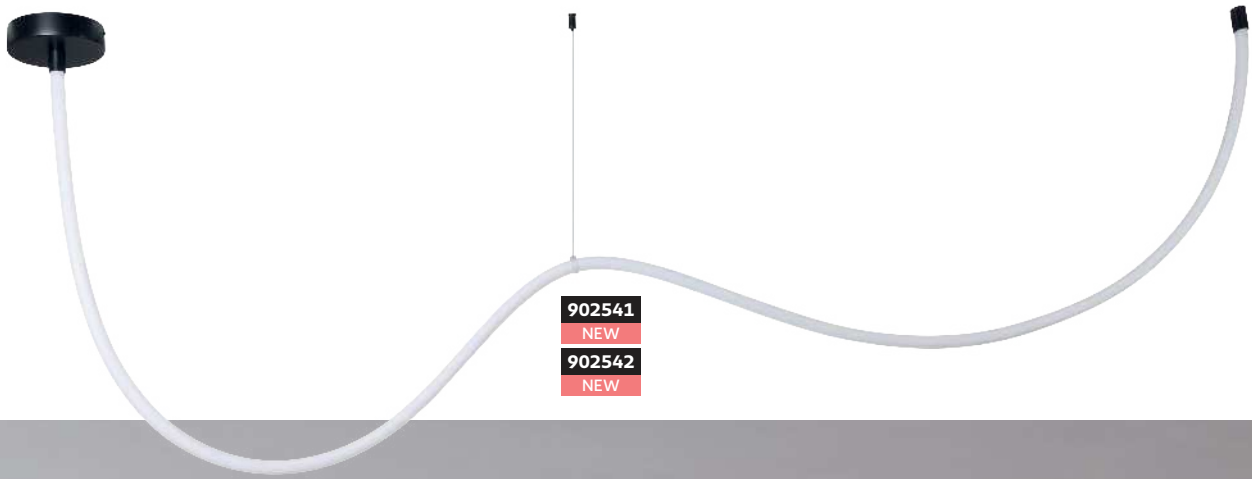

902541
NEW
902542
NEW



902543
NEW
902544
NEW

902541 GLOW WW

LED-strip; plastic, aluminium, black structure / plastic, white

LED-Band; Kunststoff, Alu, schwarz-struktur / Kunststoff, weiss

Bande LED; plastique, aluminium, structure noire / plastique, blanc

L 3000, Ø 22



1 x 24 W
1 x 2500lm

902542 GLOW WW

LED-strip; plastic, aluminium, black structure / plastic, white

LED-Band; Kunststoff, Alu, schwarz-struktur / Kunststoff, weiss

Bande LED; plastique, aluminium, structure noire / plastique, blanc

L 4000, Ø 22



1 x 24 W
1 x 3400lm

902543 GLOW NW

LED-strip; plastic, aluminium, black structure / plastic, white

LED-Band; Kunststoff, Alu, schwarz-struktur / Kunststoff, weiss

Bande LED; plastique, aluminium, structure noire / plastique, blanc

L 3000, Ø 22



1 x 24 W
1 x 2700lm

902544 GLOW NW

LED-strip; plastic, aluminium, black structure / plastic, white

LED-Band; Kunststoff, Alu, schwarz-struktur / Kunststoff, weiss

Bande LED; plastique, aluminium, structure noire / plastique, blanc

L 4000, Ø 22



1 x 24 W
1 x 3600lm



9008606385645



9008606385652



9008606385669



9008606385676

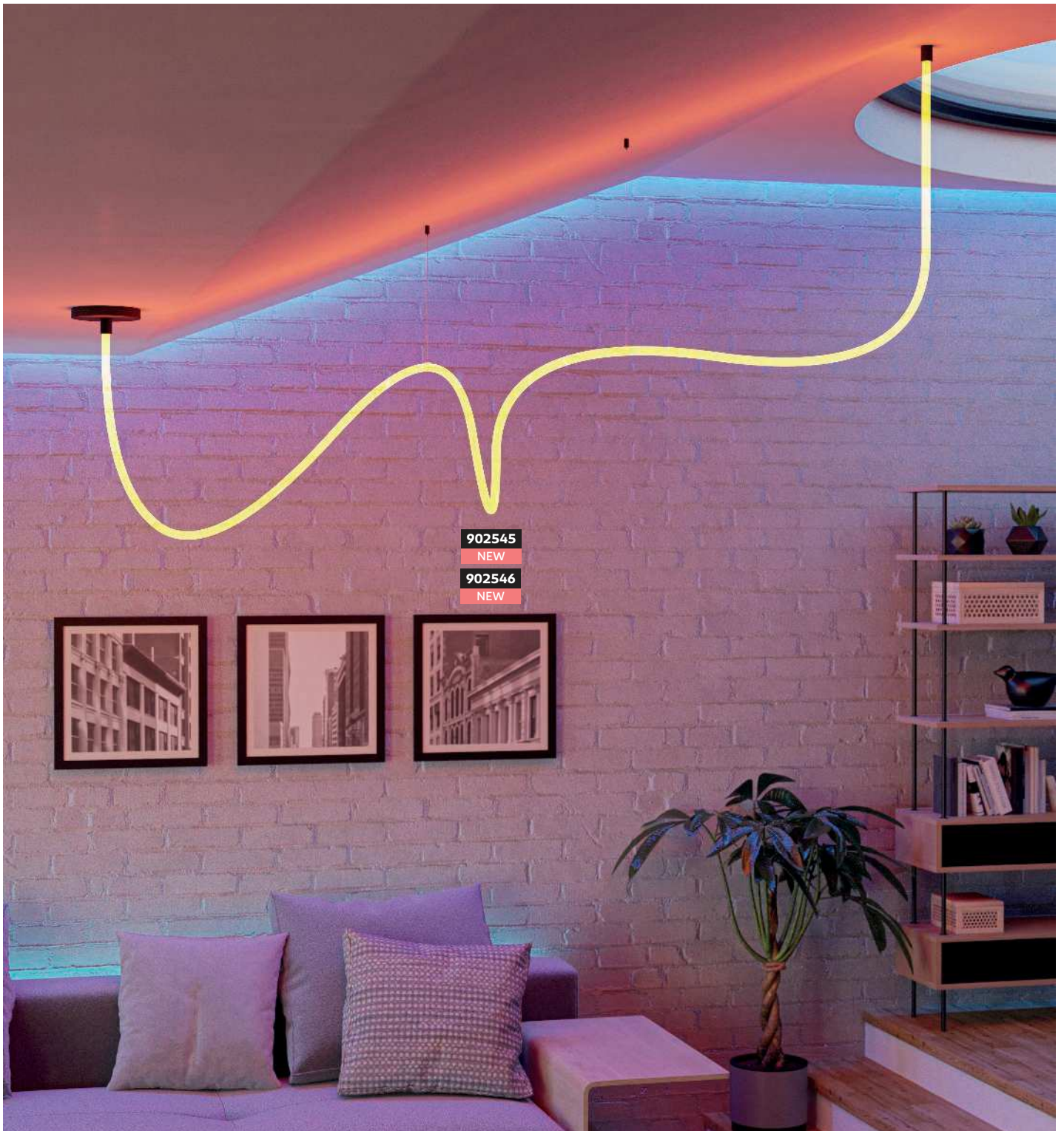

902545
NEW
902546
NEW

902545 GLOW RGBW

LED-strip; plastic, aluminium, black structure / plastic, white

LED-Band; Kunststoff, Alu, schwarz-struktur / Kunststoff, weiss

Bande LED; plastique, aluminium, structure noire / plastique, blanc

L 3000, Ø 22

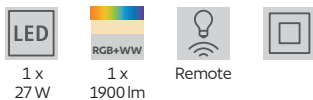

1 x
27 W

1 x
1900 lm

Remote

902546 GLOW RGBW

LED-strip; plastic, aluminium, black structure / plastic, white

LED-Band; Kunststoff, Alu, schwarz-struktur / Kunststoff, weiss

Bande LED; plastique, aluminium, structure noire / plastique, blanc

L 4000, Ø 22

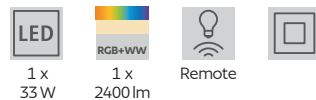

1 x
33 W

1 x
2400 lm

Remote



9008606385683



9008606385690

EGLO WORLDWIDE – SALES COMPANIES

EGLO WELTWEIT – VERTRIEBSGESELLSCHAFTEN

EGLO WORLDWIDE – SOCIÉTÉS DE VENTE



AUSTRIA
EGLO LEUCHTEN GMBH
Heiligkreuz 22
6136 Pill
T: +43 5242 6996 110 | F: +43 5242 6996 972
info-austria@eglo.com



CHILE
EGLO CHILE ILUMINACIÓN LTDA.
Av. Américo Vespucio Norte 1930
Conchali - Santiago de Chile
T: +562 2 595 2222
info-chile@eglo.com



DENMARK
EGLO DANMARK A/S
Agerbakken 20
8362 Hørning
T: +45 70 22 55 11
info-denmark@eglo.com



AUSTRALIA
EGLO LIGHTING AUSTRALIA
5/339 Archerfield Road
4077 Richlands | Queensland
T: +61 7 3375 1413 | F: +61 7 3375 1412
info@eglolighting.com.au



CHINA
Dongguan Eglo China Lighting Co., Ltd
Room 101 of Building 1, No. 1 Shangqiao Industrial
Road, Dongcheng Street,
Dongguan City, Guangdong Province.
T: +86 769 2203 3866 | F: +86 769 2203 6866
info-china@eglo.com



ESTONIA
MOODNE VALGUSTUS AS
Rävala pst. 7
10143 Tallinn
T: +372 667 6670 | F: +372 631 3195
info-estonia@eglo.com



BELGIUM
EGLO BELGIUM BV
Antwerpsesteenweg 247
2950 Kapellen
T: +32 3 250 60 80
info-belgium@eglo.com



COLOMBIA
EGLO COLOMBIA ILUMINACIÓN SAS
Autopista Norte 800 Mts adelante del Peaje de los Andes
Costado Oriental Km 19 Lote 30
Bogotá - Chia
T: +57 (1) 744 2339
info-colombia@eglo.com



FINLAND
EGLO FINLAND OY
Malmin raitti 17A
00700 Helsinki
T: +358 20 7649 820
info-finland@eglo.com



BOSNIA AND HERZEGOVINA
EGLO RASVJETA BH D.O.O.
Hrgovi Donji 178
76250 Gradacac
T: +387 35 86 85 00 | F: +387 35 82 44 41
info-Bosnia-Herzegovina@eglo.com | info@eglo.ba



COSTA RICA
EGLO COSTA RICA
Centro Comercial Calle Real local #8 de la sucursal del
BAC San José 800 metros al norte Guachipilín de Escazú
San José, Costa Rica
T: +506-2289-4690 | F: +506-2100-6384
info-costarica@eglo.com



FRANCE
EGLO FRANCE LUMINAIRE SARL
Z.A. Jeune Bois | 2 Rue de la Martinique
68274 Wittenheim
T: +33 3 89 62 50 30 | F: +33 389 6250 49
info-france@eglo.com



BULGARIA
EGLO BULGARIA EOOD
Main Road Burgas-Sofia | area 5th kilometer | Building EGLO
8000 Burgas
T: +359 888 755 509
info-bulgaria@eglo.com



CROATIA
EGLO RASVJETA D.O.O.
Jadranska avenija 9
10020 Zagreb
T: +385 1 379 40 62 | F: +385 1 379 41 04
info-croatia@eglo.com



GERMANY
EGLO LEUCHTEN HANDELS GMBH
Kleinbahnstr. 35
59759 Arnsberg
T: +49 2932 6269 0 | F: +49 2932 6269 39
info-germany@eglo.com



CANADA
EGLO CANADA INC.
20700 Route Transcanadienne
H9X 4B7 Baie D'Ufré, Quebec
T: +1 514 457 5483 | F: +1 514 457 5487
info-canada@eglo.com



CZECH REPUBLIC
EGLO CZ+SK s.r.o.
Náchodská 2479/63
193 00 Praha 9
T: +420 281 924 163
info-czechrepublic@eglo.com



GREAT BRITAIN AND IRELAND
EGLO UK LTD.
54 Denington Rd, Denington Industrial Estate
NN8 2QH Wellingborough. UK
T: +44 1604 790 986
info-UK@eglo.com

**GREECE**

EGLO HELLAS A.E.

Sykias 2 and parodos dekeleias
13679 Acharnai
T: +30 21 0800 2363
info-greece@eglo.com

**HUNGARY**

EGLO LUX KFT.

Fő út 143/A
2120 Dunakeszi
T: +36 27 341 353
info-hungary@eglo.com

**INDIA**

EGLO INDIA PRIVATE LIMITED

Building/ Block-I, Plot No. 286-289, Sector-3, Phase-II
123501 Bawal, Rewari, Haryana
T: +91 98116 48330
info-india@eglo.com

**ITALY**

EGLO ITALIANA S.R.L.

Via Giotto, 4
31021 Mogliano Veneto (TV)
T: +39 041 45 66 245 | F: +39 041 45 74 066
info-italy@eglo.com

**KAZAKHSTAN**

EGLO KAZAKHSTAN LLP

Nur-Alatau settlement, Koksarai street, bld. 40
050045 Almaty
T: +7 727 293 25 20 | M: +7 701 031 00 00
info-kazakhstan@eglo.com

**KOSOVO**

EGLO KOSOVA LLC

Lugisht e qytetit pn
20000 Prizren
T: +383 44 216 687 | SHOP: +383 49 699 100
info-kosovo@eglo.com

**LATVIA**

MOODNE VALGUSTUS AS

Rāvala pst.7
10143 Tallinn
T: +370 652 49923 | T: +372 667 6670
info-latvia@eglo.com

**LITHUANIA**

MOODNE VALGUSTUS AS

Rāvala pst.7
10143 Tallinn
T: +370 652 49923 | T: +372 667 6670
info-lithuania@eglo.com

**MALAYSIA**

EGLO ASIA SDN BHD

B-07-13, Empire Soho, Empire Subang, Jalan SS 16/1,
47500 Subang Jaya, Selangor Darul Ehsan.
T: +60162115313
info-malaysia@eglo.com

**MEXICO**

EGLO MÉXICO ILUMINACIÓN S DE RL DE CV

Prolongación Avenida López Mateos Sur N°3561,
Fraccionamiento Los Gavilanes
C.P. 45645 Tlajomulco de Zúñiga | Jalisco
T: +52 33 3687 20 95
info-mexico@eglo.com

**MIDDLE EAST**

EGLO LIGHTING MIDDLE EAST FZE

P.O. BOX 262073, LOB6, OFFICE G18
Jebel Ali, Dubai
T: +97 148810080 | F: +97 148810081
gulf@eglo.com

**MOROCCO - EGLO AFRICA**

EGLO MAGHREB LUMINAIRES SARL

219 Bd Med Zerktouni. Suite: 67
20330 Casablanca
T: +212 522 98 80 25 / -05
info-global@eglo.com | info.africa@eglo.com

**THE NETHERLANDS**

EGLO VERLICHTING NEDERLAND B.V.

Innovatiepark 20
4906 AA Oosterhout (NB)
T: +31 162 48 28 30
info-nl@eglo.com

**NORWAY**

MS BELYSNING

Gardermovegen 95B
2030 Nannestad
T: +47 63 888500 | F: +47 63 888501
info-norway@eglo.com

**PERU**

EGLO PERU S.A.C

Av Primavera 1419
Distrito de Santiago de Surco y Departamento de
Lima
T: +51 902 763 635
info-peru@eglo.com

**POLAND**

EGLO POLSKA SP. Z O.O.

Ul. Dźwiękowa 2
02-857 Warszawa
T: +48 22 644 57 55 | T: +48 22 644 89 82
info-poland@eglo.com

**PORTUGAL**

EGLO PORTUGAL ILUMINAÇÃO, LDA

Rua Fonte Parada, 125
4595-434 Seroa-Paços de Ferreira
T: +351 255 890 000
info-portugal@eglo.com

**ROMANIA**

EGLO ROMANIA PRODEXIM SRL.

Str. Atomistilor nr. 1D
077125 Magurele - Ilfov
T: +40 314 250 902 | F: +40 314 250 899
info-romania@eglo.com

**RUSSIA**

EGLO LIGHTING LLC

Varshavskoe shosse 3 | Office 23
117105 Moscow
T: +7495 789 4311
info-russia@eglo.com

**SERBIA**

EGLO RASVETA DOO

Stefana Prvovenčanog 28
11000 Beograd
T: +381 11 3981 366 | T: +381 11 44 28 465
info-serbia@eglo.com

**SLOVAKIA**

EGLO CZ+SK s.r.o

Náchodská 2479/63
193 00 Praha 9
T: +421 313 211 551
info-slovakia@eglo.com

**SLOVENIA**

EGLO RASVJETA D.O.O.

Jadranska avenija 9
10020 Zagreb
T: +385 1 379 40 62 | F: +385 1 379 41 04
info-slovenia@eglo.com

**SPAIN**

EGLO ESPANA ILUMINACIÓN S.L.

Avda. de Castilla,1 (Edf. Best Point) 2º Planta - Oficina
16A-B
28830 San Fernando de Henares, Madrid
T: +34 91 677 90 44 | F: +34 91 677 03 04
info-spain@eglo.com

**SWEDEN**

EGLO SVERIGE AB

Star Street 1
512 50 Svenljunga
T: +46 340 623 505
info-sweden@eglo.com

**SWITZERLAND**

EGLO SCHWEIZ AG

Seetalstrasse 142
6032 Emmen
T: +41 41 268 69 59
info-switzerland@eglo.com

**TURKEY**

EGLO Aydınlatma ithalat ihracat Ltd. Şti.

Eyüp Sultan Mah. Sekmen Cad. No:18/2
34885 Sancaktepe / Istanbul Samandıra
T: +90 216 311 09 -02 / -03 / -04 |
F: +90 216 311 09 / -05
info-turkey@eglo.com

**UKRAINE**

EGLO UKRAINE LTD

Vatstva Gavela boulevard, 6/7-A
03124 Kyiv
T: +38 067 670 58 61 | T: +38 067 236 52 35
info-ukraine@eglo.com | infoshop2@eglo.com

**USA**

EGLO USA, INC.

30725 Solon Industrial Parkway
44139 Solon, Ohio
T: +1 404 477 5601 | F: +1 404 420 2977
info-usa@eglo.com

HOW TO READ

ERKLÄRUNG
COMMENT LIRE

ARTICLE NUMBER & SERIES NAME
ARTIKELNUMMER & SERIENNAME
NUMÉRO D'ARTICLE & NOM DE LA SÉRIE

DIMENSIONS
DIMENSIONEN
DIMENSIONS

all dimensions in mm | alle Größen in mm | toutes dimensions en mm

L = length | Länge | longueur

B = width | Breite | largeur

H = height | Höhe | hauteur

Ø = diameter | Durchmesser | diamètre

A = projection length | Ausladung | amplitude

ET = installation depth | Einbautiefe | profondeur utile

Base = base dimensions | Sockelmaße | dimensions de base

Attention! The dimensions relate solely to the sizes of the luminaire. Any air spaces that would be relevant for a safe operating of the lamp were not considered.

Achtung! Die Größen beziehen sich nur auf die Abmessungen der Leuchte. Etwaige Lufträume, die für einen sicheren Betrieb der Leuchte notwendig sind, werden nicht berücksichtigt.

Attention! Les dimensions se réfèrent à la taille de la lampe seulement. Espacements éventuels, que seraient importants pour une opération de la lampe sans danger, n'ont pas été considérés.

PICTOGRAMS
PIKTOGRAMME
PIKTOGRAMMES

Technical details are represented as pictograms. An overview of all pictograms can be found on the next pages.

Technische Details werden als Piktogramme dargestellt. Eine Übersicht über alle Piktogramme finden Sie auf den nächsten Seiten.

Les détails techniques sont représentés sous forme de pictogrammes. Vous trouverez un aperçu de tous les pictogrammes dans les pages suivantes.

BUTTONS
BUTTONS
BOUTONS

Bulb included
Leuchtmittel inkludiert
ampoules inclus



MORADILLO

Thanks to the integrated dip switch, the colour temperature of the backlight panel can be set individually before installation - selectable between warm white, neutral white and cool white.

Beim Backlight-Panel kann dank des integrierten Dipschalters die Farbtemperatur vor der Montage individuell eingestellt werden – wählbar zwischen Warmweiß, Neutralweiß und Kaltweiß.

Sur le panneau de rétroéclairage, la température de couleur peut être réglée individuellement avant le montage grâce au dip-switch intégré - au choix entre blanc chaud, blanc neutre et blanc froid.



901487



902371



902369



901488

901487 MORADILLO
ceiling light; steel black / plastic, white
Deckenleuchte; Stahl, schwarz / Kunststoff, weiss
plafonnier; acier, noir / plastique, blanc

L 1195, B 295, H 61

LED 1x 33W 1x 4300lm



9008606340026

902371 MORADILLO
ceiling light; steel black / plastic, white
Deckenleuchte; Stahl, schwarz / Kunststoff, weiss
plafonnier; acier, noir / plastique, blanc

L 595, B 595, H 61

LED 1x 32.5W 1x 4350lm



9008606369492

902369 MORADILLO
ceiling light; steel black / plastic, white
Deckenleuchte; Stahl, schwarz / Kunststoff, weiss
plafonnier; acier, noir / plastique, blanc

L 393, B 393, H 61

LED 1x 18.8W 1x 2300lm



9008606369485

901488 MORADILLO
ceiling light; steel black / plastic, white
Deckenleuchte; Stahl, schwarz / Kunststoff, weiss
plafonnier; acier, noir / plastique, blanc

L 1195, B 145, H 65

LED 1x 28W 1x 3700lm



9008606340033

106 LED PANEL LUMINAIRES

DESCRIPTION
BESCHREIBUNG
DESCRIPTION

The product description is composed as follows:
luminaire type; enclosure material, enclosure colour / glass or shade material, glass or shade colour

Die Produktbeschreibung setzt sich wie folgt zusammen:
Leuchtenart; Gehäusematerial, Gehäusefarbe / Schirm- bzw. Glasmaterial, Schirm- bzw. Glasfarbe

La description du produit est composée comme suit:
type de luminaire; matériel de boîtier, couleur de boîtier / matériel de verre ou abat-jour, couleur de verre ou abat-jour

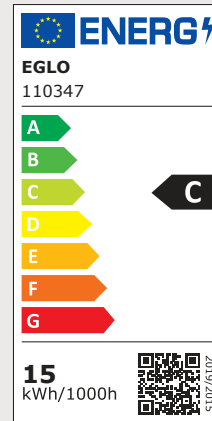

The new energy label must be indicated on all light sources with a luminous flux between 60 and 82,000 lumens and LED. This applies to lamps, LED modules and luminaires where the light source cannot be removed without destroying it.

Das neue Energielabel muss auf allen Lichtquellen mit einem Lichtstrom zwischen 60 und 82.000 Lumen und LED angegeben werden. Dies gilt für Lampen, LED-Module und Leuchten, bei denen die Lichtquelle nicht zerstörungsfrei entnommen werden kann.

Le nouveau label énergétique doit être indiqué sur toutes les sources lumineuses dont le flux lumineux est compris entre 60 et 82 000 lumens et sur les LED. Cela s'applique aux lampes, aux modules LED et aux luminaires dont la source lumineuse ne peut être retirée sans être détruite.

The information on the label includes:

Die Angaben auf dem Etikett beinhalten:

Les informations figurant sur l'étiquette sont les suivantes :

- Name / Trademark
Name / Warenzeichen
Nom / marque de commerce
- Model
Modell
Modèle
- Energy label scale A-G
Energielabel-Skala A-G
Échelle d'étiquetage énergétique A-G
- Energy consumption for 1,000 hours of use
Energieverbrauch bei 1.000 Stunden Nutzung
Consommation d'énergie pour 1 000 heures d'utilisation
- Energy efficiency class of the product
Energieeffizienzklasse des Produkts
Classe d'efficacité énergétique du produit
- QR Code to EPREL (Product Database of the European Product Registry for Energylabelling)
QR Code zur EPREL (Produktdatenbank der European Product Registry for Energylabelling)
Code QR pour EPREL (base de données des produits du registre européen des produits pour l'étiquetage énergétique)

The energy spectrum ranges from G to A.

Das Energiespektrum reicht von G bis A.

Le spectre énergétique va de G à A.

PENETO
recessed light
Einbauleuchte
luminaire encastrable

Material / Colour	Size	Cutout	Watt	Lumen	Quantity	Material-Nr.	EAN code
steel, white Stahl, weiss acier, blanc	Ø 87, ET 115	Ø 70	3 x 4,6 W	3 x 400 lm	3	94406	9002759944063
steel, satin nickel Stahl, nickel-matt acier, nickel mat	Ø 87, ET 115	Ø 70	4,6 W	400 lm	1	94242	9002759944242
	Ø 87, ET 115	Ø 70	3 x 4,6 W	3 x 400 lm	3	94408	9002759944087
steel, chrome Stahl, chrom acier, chrome	Ø 87, ET 115	Ø 70	3 x 4,6 W	3 x 400 lm	3	94407	9002759944070
steel, black Stahl, schwarz acier, noir	Ø 87, ET 115	Ø 70	3 x 4,6 W	3 x 400 lm	3	900752	9008606253845

RECESSED DOWNLIGHTS 175

TABLE
TABELLE
TABLEAU

Some products have the same appearance and only differ in terms of technical data or functions such as light colour, dimmability, IP class, etc. These are shown in a table for a better overview.

Einige Produkte haben die selbe Optik und unterscheiden sich nur durch technische Daten oder Funktionen wie: Lichtfarbe, Dimmbarkeit, IP-Klasse, etc. Diese werden für den besseren Überblick in einer Tabelle dargestellt.

Certains produits ont la même apparence et ne diffèrent qu'en termes de données techniques ou de fonctions, telles que la couleur de la lumière, la possibilité de gradation, la classe IP, etc. Pour une meilleure vue d'ensemble, ils sont présentés dans un tableau.

LEGEND

LEGENDE
LÈGENDE

SOCKETS FASSUNGEN DOUILLES

 E14

 E27

 G9

 GU10

 LED

 R7S

BULBS LEUCHTMITTEL AMPOULES

 A60

 AGL

 C35

 G9

 GLOBE

 GU10

 HALOGEN

 P45

 R50

 STAB 118 mm

LIGHT COLOUR & LUMEN LICHTFARBE & LUMEN COULEUR LUMINEUX & LUMEN

The colours of the LED are represented as pictogrammes (see below), their luminous flux directly beneath. The luminous flux is quoted in lumen and describes the amount of light generated by the LED. The higher the value, the brighter is the lamp. Lumens are LED boards and are the light measurement value in bulbs.

Die Farben der LED werden als Piktogramm (siehe unten) dargestellt, deren Lichtstrom direkt darunter. Der Lichtstrom wird in Lumen gemessen und gibt die erzeugte Lichtmenge der LED an. Je höher der Wert, desto heller das Produkt. Lichtstromangaben (Lumen) sind Platinen- bzw. Leuchtmittelwerte.

Les couleurs de LED ont représentés sous forme de pictogrammes, leur flux lumineux directement en dessous. L'unité de flux lumineux est le lumen et il mesure la quantité de lumière générée par les LED. Plus la valeur est élevée, plus la lampe est lumineuse. Les lumens sont l'unité de mesure de l'intensité lumineuse des ampoules et des panneaux led intégrés.

 RGB
RGB
RGB

 RGB + warmwhite
RGB + warmweiß
RGB + blanc chaud

 RGB + neutralwhite
RGB + neutralweiß
RGB + blanc neutre

 RGB + tunable white
RGB + tunable white
RGB + tunable white

 tunable
WHITE
tunable white
tunable white
tunable white

 warm
WHITE
warm white
warmweiß
blanc chaud

 neutral
WHITE
neutral white
neutralweiß
blanc neutre

 TRI colour
dreifarbig
tricolore

 WW+CW
warm white + cold white
warm weiß + kaltweiß
blanc chaud + blanc froid

 WW+NW
warmwhite + neutralwhite
warmweiß + neutralweiß
blanc chaud + blanc neutre

SWITCHES & SENSORS SCHALTER & SENSOREN INTERRUPTEUR & CAPTEURS

 incl. cable & plug
inkl. Kabel & Stecker
câble & connecteur inclus

 internal dimmer
eingebauter Dimmer
variateur intégré

 button switch
Druckknopf
interrupteur de pression

 rocker switch
Wippschalter
interrupteur à bascule

 pedal dimmer
Trittdimmer
variateur à pied

 cable switch
Kabelschalter
interrupteur à câble

 remote control
Fernbedienung
télécommande

 sensor
Sensor
sensor

 "Touch me" ON/OFF
"Touch me" EIN/AUS
"Touch me" ON/OFF

 "Touch me" ON/OFF & dimm
"Touch me" EIN/AUS & Dimmen
"Touch me" ON/OFF & graduable

 pull switch
Zugschalter
interrupteur à bascule

 CCT Switch
CCT Schalter
CCT interrupteur

 Height adjust manual
Höhenverstellung manuell
Réglage manuel de la hauteur

FUNCTIONS & COMFORT
FUNKTIONEN & KOMFORT
FONCTIONS & CONFORT



incl. battery
inkl. Akku
incl. pile



battery specifications
Batteriespezifikationen
spécifications des piles



corner mount possible
Eckmontage möglich
montage en coin possible



cutout (in mm)
Ausschnitt (in mm)
perçage du panneau (en mm)



dimmmable
dimmmar mit externen Dimmer
graduabile



not dimmmable
nicht dimmmbar
ne pas graduabile



Can be operated via control unit
Bedienbar über Steuergerät
Peut être commandé par une unité de contrôle



packaging / delivery unit
Verpackungs- / Liefereinheit
unité d'emballage / de livraison



Voltage
Volt
Voltage



WATT Watt



USB connection
USB-Anschluss
Connexion USB



Qi-Charger



Step Dimming
Stufenweises Dimmen
Gradation par paliers

PROTECTION CLASS
SCHUTZKLASSE
CLASSE DE PROTECTION

The protection class indicates to what extent the lamp is protected against electric shock. All lamps in this catalogue are at least protected with the protection class 1 - a higher class is specified in the information box of the respective lamp.

Die Schutzklasse gibt an, inwiefern ein Produkt gegen einen elektrischen Schlag gesichert ist. Alle Leuchten in diesem Katalog sind mit mindestens Schutzklasse 1 gesichert, bei höheren Klassen wird das Symbol im Infokasten der Leuchte angegeben.

La classe de protection indique, dans quelle mesure la lampe est protégée contre les chocs électriques. Tous les lampes dans ce catalogue sont protégées au moins avec la classe 1 - une classe plus élevée est indiquée dans l'information de la lampe.



protection class 2: protective insulation
Schutzklasse 2: Schutzisolierung
classe de protection 2: double isolation ou renforcée



protection class 3: protective low voltage
Schutzklasse 3: Schutzkleinspannung
classe de protection 3: très basse tension de sécurité

PROTECTION RATING
SCHUTZGRAD
INDICE DE PROTECTION

The protection rating ensures the operational safety of luminaires. The first number specifies the extent of the protection against the ingress of foreign bodies; the second number identifies the humidity protection grade. All luminaires in this catalogue are at least protected with the rating IP20 - a higher rating is specified in the information box of the luminaire.

Der Schutzgrad gewährleistet die Betriebssicherheit von Leuchten. Die erste Ziffer des IP Grades beschreibt den Schutzzumfang gegen das Eindringen von Fremdkörpern, die zweite Ziffer informiert über den Grad des Feuchtigkeitsschutzes. Alle Leuchten in diesem Katalog sind mit mindestens Schutzgrad IP20 gesichert, bei höheren Graden wird das Symbol im Infokasten der Leuchte angegeben.

L'indice de protection assure la sécurité opérationnelle des luminaires. Le premier chiffre indique à quel point la protection est efficace contre l'insertion de corps étrangers; le second chiffre indique quant à lui le degré de protection par rapport à l'humidité. Tous les luminaires dans ce catalogue sont protégés au moins avec l'indice IP20 - un indice plus élevé est indiqué dans l'information d'article.



IP33



IP44



IP54



IP55



IP65



IP67

REGISTER SERIES NAME

REGISTER SERIENNAMEN

REGISTRÈ NOME DE PRODUITS

Name Name Nom	Page Seite Page	Name Name Nom	Page Seite Page	Name Name Nom	Page Seite Page
BARRANCO	127	GLOW NW	204	SANIA-Z	36
BARRANCO GU10	167-170	GLOW RGBW	205	SARSINA	114
BOHOYO	199	GLOW WW	204	SARSINA-Z	41
CALONGE RGB	149	HERRORA-Z	45	TEDO 1	176
CALPINO-Z	37	KOB LED	197	TPLUS 6 LENS SPOT	85, 89
CAROSSO	177	LED STRIPE-Z	61	TPLUS EXTENSION	83, 87
CAROSSO-Z	28-29, 158-159	MECINOS	163	TPLUS FLAT LIGHT	84, 88
CONNECT Z REMOTE	24	MELITELLO-Z	34-35	TPLUS PENDANT	85, 89
CONNECT-Z SWITCH	25	MENGIBAR MOUNTING	153	TPLUS SLIM SPOT	84, 88
CRESPILLO	196	MENGIBAR SPHERE	152-153	TPLUS SPHERE SPOT	85, 89
EASYT FLAT SPOT	73, 79	MENGIBAR TUBE	150-151	TPLUS STARTER SET	83, 87
EASYT CONNECTOR	70, 76	MORADILLO	104-106	TPLUS WIDE SPOT	84, 88
EASYT CORNER	70, 76	MORADILLO-R	107	TURCONA-CCT	115
EASYT E27 ADAPTER	71, 77	MORADILLO-Z	48-51	TURCONA-Z	40, 46-47
EASYT FEEDER	69, 75	NEON-STRIFE-Z	60	YEBRA	148
EASYT LONG DIFFUSO	72, 78	PADROGIANO-Z	42-44	YEBRA-Z	27, 157
EASYT PENDANT	73, 79	PENETO	174-175	ZARATE	162
EASYT SET 3 SPOTS	68, 74	PINEDA	138-139		
EASYT SET 4 SPOTS	68, 74	POLASSO	198		
EASYT SPHERE PENDA	73, 79	PUCK CCT	122		
EASYT SPHERE SPOT	72, 78	PUCK CCT/DIM	122		
EASYT SPOT RING	71, 77	PUCK COB NW	123		
EASYT SPOT RIPPLE	72, 78	PUCK COB WW	122		
EASYT SPOT TUBE	71, 77	PUCK SMART RGB+TW	123		
EASYT T-CONNECTOR	70, 76	RABASSA	115		
EASYT TRACK	69, 75	RAPITA	136-137		
FAVAZZINA	172-173	ROVITO	96-99		
FUEVA 1	194-195	ROVITO-R	100-103		
FUEVA 5	134, 192-193	ROVITO-Z	56-59		
FUEVA 6	128-133, 184-191	SALABATE	146-147		
FUEVA 6-Z	30-33, 160	SALICETO	142-144		
FUEVA FLEX	132	SALICETO-Z	26, 156		
GALLIZZI-Z	38-39	SALOBRENA 1	108-113		
GEDREZ	126	SALOBRENA-Z	52-55		



REGISTER ARTICLE NUMBER

REGISTER ARTIKEL NUMMER

REGISTRE NUMÉROS D'ARTICLE

Number Nummer Numéro	Page Seite Page	Number Nummer Numéro	Page Seite Page	Number Nummer Numéro	Page Seite Page	Number Nummer Numéro	Page Seite Page	Number Nummer Numéro	Page Seite Page	Number Nummer Numéro	Page Seite Page	Number Nummer Numéro	Page Seite Page
30761	192	98301	143	300194	126	900762	41	901306	184	901389	131	901446	98
30762	193	98302	144	300195	126	900763	29, 159	901307	185	901391	133	901447	98
32811	109	98303	143	300196	126	900764	29, 159	901308	186	901392	133	901448	98
32812	108	98304	144	900044	52	900765	29, 159	901309	187	901393	133	901449	99
32813	108	98305	143	900045	52	900766	29, 159	901311	188	901394	128	901451	99
33391	143	98306	144	900046	52	900816	177	901312	189	901395	128	901452	99
33394	144	98307	143	900047	53	900817	110	901313	190	901396	131	901453	99
33996	142	98607	142	900048	53	900818	110	901314	191	901397	131	901454	100
33997	143	98609	143	900049	54	900819	110	901315	184	901398	131	901455	100
61358	113	98611	144	900051	54	900821	111	901316	185	901399	133	901456	101
61359	113	99099	24	900052	54	900822	111	901317	186	901401	133	901457	101
61361	113	99191	134	900053	55	900931	132	901318	187	901402	133	901458	102
93706	197	99192	134	900054	40	900932	132	901319	188	901403	128	901459	102
93707	197	99193	134	900055	40	900933	132	901321	189	901404	128	901461	103
94235	174	99204	134	900056	40	900934	132	901322	190	901405	131	901462	103
94236	174	99208	134	900057	46	900935	132	901323	191	901406	131	901463	57
94237	174	99258	192	900058	46	900936	132	901324	184	901407	131	901464	57
94242	175	99259	192	900059	46	900937	115	901325	185	901408	133	901465	57
94406	175	99263	192	900061	47	900964	136	901326	186	901409	133	901466	59
94407	175	99264	192	900062	47	900965	136	901328	188	901411	133	901467	59
94408	175	99337	196	900095	55	900966	137	901329	189	901412	128	901468	59
94501	198	99338	196	900116	25	900967	137	901331	190	901413	131	901469	59
94502	198	99493	147	900181	192	900968	137	901332	184	901414	131	901471	56
94503	198	99548	45	900182	192	900969	137	901333	185	901416	128	901472	56
95359	176	99549	45	900183	193	901011	192	901334	186	901417	131	901473	56
95821	138	99639	45	900184	193	901012	192	901335	188	901418	131	901474	58
95823	138	99643	163	900251	162	901013	192	901336	189	901421	32	901475	58
95851	139	99644	163	900456	177	901014	192	901337	190	901422	33	901476	58
95853	139	99669	26, 156	900481	42	901043	199	901372	32	901425	30, 160	901477	58
96151	112	99671	26, 156	900482	43	901044	199	901373	32	901426	30, 160	901487	106
96153	112	99686	61	900483	42	901108	60	901374	33	901427	30, 160	901488	106
96154	112	99687	61	900484	43	901109	60	901375	33	901429	30, 160	901491	104
96901	162	99726	196	900485	43	901117	149	901376	32	901431	30, 160	901492	104
97262	194	99727	196	900486	44	901118	149	901377	32	901432	30, 160	901494	105
97263	194	99836	115	900487	44	901168	28, 158	901378	33	901434	30, 160	901495	105
97268	195	300184	126	900744	138	901169	28, 158	901379	33	901435	30, 160	901504	107
97502	114	300185	126	900745	143	901297	184	901381	32	901436	30, 160	901505	50
97503	114	300186	126	900746	143	901298	185	901382	32	901438	96	901506	50
98025	109	300187	126	900747	143	901299	186	901383	33	901439	96	901507	51
98129	108	300188	126	900749	139	901301	187	901384	33	901441	96	901509	51
98238	147	300189	126	900752	175	901302	188	901385	128	901442	97	901511	51
98241	147	300191	126	900758	41	901303	189	901386	128	901443	97	901512	49
98243	142	300192	126	900759	41	901304	190	901387	131	901444	97	901513	49
98244	142	300193	126	900761	41	901305	191	901388	131	901445	97	901514	49

Number Number Numéro	Page Seite Page	Number Number Numéro	Page Seite Page	Number Number Numéro	Page Seite Page	Number Number Numéro	Page Seite Page
901516	48	901759	173	902251	170	902328	144
901517	48	901761	173	902252	170	902329	142
901638	69	901762	184	902253	170	902331	142
901639	69	901763	185	902254	168	902333	122
901641	70	901764	186	902255	168	902334	122
901642	70	901765	188	902256	168	902335	123
901644	71	901766	189	902257	168	902336	123
901647	71	901767	190	902258	168	902338	122
901648	71	901903	38	902259	168	902369	106
901651	73	901904	38	902261	127	902371	106
901652	68	901905	38	902262	127	902541	204
901653	68	901906	39	902263	127	902542	204
901654	75	901907	39	902264	127	902543	204
901655	75	901908	39	902265	127	902544	204
901656	76	901941	35	902266	127	902545	205
901657	76	901942	35	902267	127	902546	205
901659	77	901943	34	902268	127	902626	72
901663	77	901944	34	902269	127	902627	78
901664	77	901955	36	902271	146	902628	73
901666	79	901956	36	902272	146	902629	79
901667	74	902224	167	902273	146	902659	37
901668	74	902225	167	902274	146	902681	73
901669	83	902226	167	902275	146	902682	79
901683	84	902227	167	902276	146	902683	72
901684	84	902228	167	902277	142	902684	78
901685	84	902229	167	902278	142	902687	85
901686	85	902231	167	902279	142	902688	89
901687	85	902232	167	902281	143	902689	37
901691	87	902233	167	902282	143	902691	72
901706	88	902234	170	902283	144	902692	72
901707	88	902235	170	902284	144	902721	151
901708	88	902236	170	902285	144	902722	151
901709	89	902237	170	902286	26, 156	902723	151
901711	89	902238	170	902287	26, 156	902724	152
901725	32	902239	170	902296	148	902725	152
901726	32	902241	168	902297	148	902726	153
901728	33	902242	168	902298	27, 157	902727	153
901729	33	902243	168	902299	27, 157	902871	78
901753	83	902244	168	902301	105	902872	78
901754	87	902245	168	902302	107	902905	153
901755	172	902246	168	902303	107	902906	150
901756	172	902247	170	902305	107	902907	153
901757	172	902248	170	902326	70		
901758	173	902249	170	902327	76		



All previous catalogues and price lists are no longer valid with the issue of this catalogue. Errors, misprints, model and price changes and technical modifications are reserved. We deliver based on our terms of delivery and payment. Our products comply with the European light norm EN60598. Products with the ENEC test mark are conforming to the guideline 2006/95/EG. Products with additional safety remarks (e.g protection class, IP) are identified within the product family with the relevant symbol and number. The content of this catalogue is protected under copyright law for EGLO Leuchten GmbH. All rights reserved. Our specific written consent must be obtained before using any illustrations and texts. The pictures are 4C prints and may differ from the original. The product pictures and ambiences in this catalogue can deviate from reality, and they do not necessarily concur with the usual application of the product. EGLO does not assume liability for the correctness, completeness or the application depiction of the products and/or the product information.

Design, layout and composition:
EGLO GmbH, 6136 Pöhl - AUSTRIA
Print: Samson Druck GmbH, 5581 St. Margarethen - AUSTRIA
Pictures: EGLO, Adobe Stock, istockphoto.com, shutterstock.com

Mit diesem Katalog verlieren alle vorhergehenden Kataloge und Preislisten ihre Gültigkeit. Irrtümer, Druckfehler, Modell- und Preisänderungen sowie technische Änderungen vorbehalten. Wir liefern zu unseren Liefer- und Zahlungsbedingungen. Unsere Produkte entsprechen der europäischen Leuchtnorm EN 60598. Produkte mit dem ENEC Prüfzeichen sind konform mit der Richtlinie 2006/95/EG. Produkte mit weiteren Sicherheitshinweisen (z. B. Schutzklasse, IP) sind mit Symbol und Zahl bei der Produktfamilie ausgezeichnet. Der Inhalt dieses Kataloges ist für die EGLO Leuchten GmbH urheberrechtlich geschützt. Alle Rechte sind vorbehalten. Bilder und Texte dürfen nicht ohne vorherige ausdrückliche, schriftliche Genehmigung verwendet werden. Die Abbildungen sind 4C Drucke und können vom Original abweichen.

Die Katalogbilder und die gezeigten Darstellungen der Produkte können von der Wirklichkeit abweichen und nicht den üblichen Produktanwendungen entsprechen. EGLO übernimmt keine Haftung für die Richtigkeit, Vollständigkeit und Anwendungsdarstellung der Produkte und Produktinformationen.

Gestaltung, Layout und Satz:
EGLO GmbH, A-6136 Pöhl - AUSTRIA
Druck: Samson Druck GmbH, 5581 St. Margarethen - AUSTRIA
Bilder: EGLO, Adobe Stock, istockphoto.com, shutterstock.com

Le présent catalogue remplace tous les catalogues et tarifs précédents. Sous réserve d'erreurs, de fautes d'impression, de modification des modèles et de changement de prix et de technique. Nous livrons sur la base de nos conditions de livraison et de paiement. Nos produits sont conformes aux normes européennes EN 60598 et portent le marquage CE. Les produits portant la marque ENEC sont conformes à la Directive 2006/95/EG. Les produits portant d'autres indications de sécurité (par exemple classe de protection, IP) sont identifiés par le symbole et le nombre correspondants dans la famille de produits.

Le contenu du présent catalogue est protégé pour la société EGLO Leuchten GmbH par un copyright. Tous droits réservés. Toute reproduction d'images et du texte est interdite sans autorisation explicite par écrit préalable. Les images sont imprimées en 4C et peuvent différer de l'original.

Les images des produits et les ambiences dans le catalogue peuvent dévier de la réalité et ne sont pas nécessairement en ligne avec l'usage habituel du produit. EGLO n'engage pas sa responsabilité sur la justesse des images et sur les informations relatives à l'usage pouvant être fait des produits.

Conception, maquette et composition :
EGLO GmbH, A-6136 Pöhl - AUSTRIA
Presse: Samson Druck GmbH, 5581 St. Margarethen - AUSTRIA
Images: EGLO, Adobe Stock, istockphoto.com, shutterstock.com

03-2026

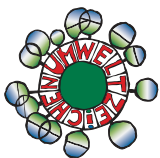

printed according to the Austrian Ecolabel criteria for printed matter, UW-Nr. 837

gedruckt nach der Richtlinie "Druckerzeugnisse" des Österreichischen Umweltzeichens, UW-Nr. 837

imprimé selon la directive „Produits imprimés du label écologique autrichien, UW-Nr. 837





EGLO Leuchten GmbH
Heiligkreuz 22
A-6136 Pill
Tel. +43 (0) 5242 6996
Fax +43 (0) 5242 6996-972
info@eglo.com
www.eglo.com